

SimPowerSystems™

User's Guide (Specialized Technology)

Hydro-Québec

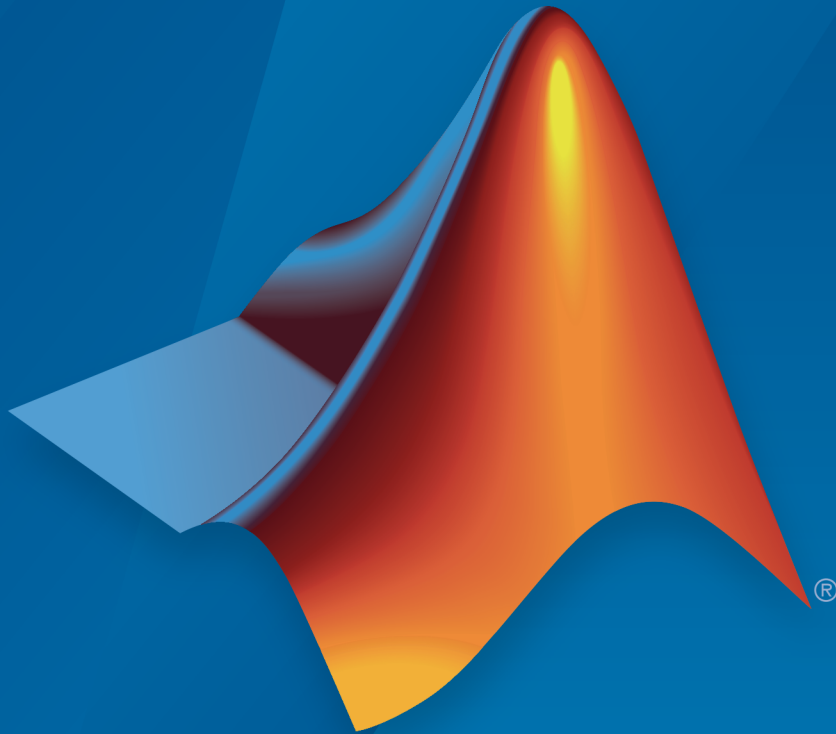

MATLAB® & SIMULINK®

R2015b

 MathWorks®

How to Contact MathWorks



Latest news: www.mathworks.com
Sales and services: www.mathworks.com/sales_and_services
User community: www.mathworks.com/matlabcentral
Technical support: www.mathworks.com/support/contact_us



Phone: 508-647-7000



The MathWorks, Inc.
3 Apple Hill Drive
Natick, MA 01760-2098

SimPowerSystems™ User's Guide (Specialized Technology)

© COPYRIGHT 1998–2015 by Hydro-Québec and The MathWorks, Inc.

The software described in this document is furnished under a license agreement. The software may be used or copied only under the terms of the license agreement. No part of this manual may be photocopied or reproduced in any form without prior written consent from The MathWorks, Inc.

FEDERAL ACQUISITION: This provision applies to all acquisitions of the Program and Documentation by, for, or through the federal government of the United States. By accepting delivery of the Program or Documentation, the government hereby agrees that this software or documentation qualifies as commercial computer software or commercial computer software documentation as such terms are used or defined in FAR 12.212, DFARS Part 227.72, and DFARS 252.227-7014. Accordingly, the terms and conditions of this Agreement and only those rights specified in this Agreement, shall pertain to and govern the use, modification, reproduction, release, performance, display, and disclosure of the Program and Documentation by the federal government (or other entity acquiring for or through the federal government) and shall supersede any conflicting contractual terms or conditions. If this License fails to meet the government's needs or is inconsistent in any respect with federal procurement law, the government agrees to return the Program and Documentation, unused, to The MathWorks, Inc.

Trademarks

MATLAB and Simulink are registered trademarks of The MathWorks, Inc. See www.mathworks.com/trademarks for a list of additional trademarks. Other product or brand names may be trademarks or registered trademarks of their respective holders.

Patents

MathWorks products are protected by one or more U.S. patents. Please see www.mathworks.com/patents for more information.

Revision History

January 1998	First printing	Version 1.0 (Release 10)
September 2000	Second printing	Revised for Version 2.1 (Release 12)
June 2001	Online only	Revised for Version 2.2 (Release 12.1)
July 2002	Online only	Revised for Version 2.3 (Release 13) (Renamed from <i>Power System Blockset User's Guide</i>)
February 2003	Third printing	Revised for Version 3.0 (Release 13SP1)
June 2004	Online only	Revised for Version 3.1 (Release 14)
October 2004	Fourth printing	Revised for Version 4.0 (Release 14SP1)
March 2005	Online only	Revised for Version 4.0.1 (Release 14SP2)
May 2005	Online only	Revised for Version 4.1 (Release 14SP2+)
September 2005	Online only	Revised for Version 4.1.1 (Release 14SP3)
March 2006	Online only	Revised for Version 4.2 (Release 2006a)
September 2006	Online only	Revised for Version 4.3 (Release 2006b)
March 2007	Online only	Revised for Version 4.4 (Release 2007a)
September 2007	Online only	Revised for Version 4.5 (Release 2007b)
March 2008	Online only	Revised for Version 4.6 (Release 2008a)
October 2008	Online only	Revised for Version 5.0 (Release 2008b)
March 2009	Online only	Revised for Version 5.1 (Release 2009a)
September 2009	Online only	Revised for Version 5.2 (Release 2009b)
March 2010	Online only	Revised for Version 5.2.1 (Release 2010a)
September 2010	Online only	Revised for Version 5.3 (Release 2010b)
April 2011	Online only	Revised for Version 5.4 (Release 2011a)
September 2011	Online only	Revised for Version 5.5 (Release 2011b)
March 2012	Online only	Revised for Version 5.6 (Release 2012a)
September 2012	Online only	Revised for Version 5.7 (Release 2012b)
March 2013	Online only	Revised for Version 5.8 (Release 2013a)
September 2013	Online only	Revised for Version 6.0 (Release 2013b) (Renamed from <i>SimPowerSystems™ User's Guide</i>)
March 2014	Online only	Revised for Version 6.1 (Release 2014a) (Renamed from <i>SimPowerSystems™ User's Guide (Second Generation)</i>)
October 2014	Online only	Revised for Version 6.2 (Release 2014b)
March 2015	Online only	Revised for Version 6.3 (Release 2015a)
September 2015	Online only	Revised for Version 6.4 (Release 2015b)

Acknowledgments

Getting Started

1

Product Overview	1-2
Introduction	1-2
The Role of Simulation in Design	1-2
Required and Related Products	1-3
Build and Simulate a Simple Circuit	1-4
Introduction	1-4
Building the Electrical Circuit with the SimPowerSystems Specialized Technology Library	1-5
Interfacing the Electrical Circuit with Other Simulink Blocks	1-9
Measuring Voltages and Currents	1-10
Basic Principles of Connecting Capacitors and Inductors ...	1-10
Using the Powergui Block to Simulate SimPowerSystems Models	1-11
Analyze a Simple Circuit	1-12
Introduction	1-12
Electrical State Variables	1-12
State-Space Representation Using power_analyze	1-12
Steady-State Analysis	1-13
Frequency Analysis	1-14
Specify Initial Conditions	1-21
Introduction	1-21
State Variables	1-21

Initial States	1-22
Specify Initial Electrical States with Powergui	1-23
Simulating Transients	1-26
Introduction	1-26
Simulating Transients with a Circuit Breaker	1-26
Discretizing the Electrical System	1-28
Introducing the Phasor Simulation Method	1-31
Introduction	1-31
When to Use the Phasor Solution	1-31
Phasor Simulation of a Circuit Transient	1-32

Advanced Components and Techniques

2

Introducing Power Electronics	2-2
Introduction	2-2
Simulation of the TCR Branch	2-3
Simulation of the TSC Branch	2-6
Simulate Variable Speed Motor Control	2-9
Introduction	2-9
Building and Simulating the PWM Motor Drive	2-10
Using the Multimeter Block	2-16
Discretizing the PWM Motor Drive	2-18
Performing Harmonic Analysis Using the FFT Tool	2-18
Three-Phase Systems and Machines	2-22
Introduction	2-22
Three-Phase Network with Electrical Machines	2-22
Machine Initialization Tool	2-25
Load Flow Tool	2-27
Using the Phasor Solution Method for Stability Studies ...	2-45
Building and Customizing SimPowerSystems Models	2-49
Introduction	2-49
Modeling a Nonlinear Inductance	2-49
Modeling a Nonlinear Resistance	2-54
Connecting Your Model with Other Nonlinear Blocks	2-57

Improving Simulation Performance

3

How SimPowerSystems Software Works	3-2
Limitations of the Nonlinear Models	3-3
Choosing an Integration Method	3-5
Introduction	3-5
Continuous Versus Discrete Solution	3-5
Phasor Solution Method	3-5
Simulating with Continuous Integration Algorithms	3-7
Choosing an Integration Algorithm	3-7
Simulating Switches and Power Electronic Devices	3-8
Using the Ideal Switching Device Method	3-8
Simulating Discretized Electrical Systems	3-14
Introduction	3-14
Discretizing Switches and Power Electronics	3-15
Discretizing Electrical Machines	3-16
Increasing Simulation Speed	3-20
Ways to Increase Simulation Speed	3-20
Using Accelerator Mode and Simulink Coder	3-20
Creating Your Own Library of Models	3-22
Change Circuit Parameters	3-23
Introduction	3-23
Example of MATLAB Script Performing a Parametric Study	3-23

Electric Drives Library	4-2
Electric Drives Library Overview	4-2
What Is an Electric Drive?	4-3
Three Main Components of an Electric Drive	4-3
Multiquadrant Operation	4-5
Average-Value Models	4-6
User Interface	4-7
General Layout of the Library's GUIs	4-7
Features of the GUIs	4-8
Simulate a DC Motor Drive	4-11
Introduction	4-11
Regenerative Braking	4-12
Example: Thyristor Converter-Based DC Motor Drive	4-12
Simulate an AC Motor Drive	4-33
Introduction	4-33
Dynamic Braking	4-33
Modulation Techniques	4-34
Open-Loop Volts/Hertz Control	4-38
Closed-Loop Speed Control with Slip Compensation	4-40
Flux-Oriented Control	4-40
Direct Torque Control	4-43
Example: AC Motor Drive	4-44
Mechanical Models	4-61
Mechanical Shaft Block	4-61
Speed Reducer Block	4-62
Mechanical Coupling of Two Motor Drives	4-63
Introduction	4-63
System Description	4-64
Speed Regulated AC4 with Torque Regulated DC2	4-66
Torque Regulated AC4 with Speed Regulated DC2	4-68
Winding Machine	4-70
Introduction	4-70
Description of the Winder	4-70
Block Description	4-72
Simulation Results	4-74

Robot Axis Control Using Brushless DC Motor Drive	4-78
Introduction	4-78
Description of the Robot Manipulator	4-78
Position Control Systems for Joints 1 and 2	4-79
Modeling the Robot Position Control Systems	4-80
Tracking Performance of the Motor Drives	4-84
Building Your Own Drive	4-89
Introduction	4-89
Description of the Drive	4-90
Modeling the Induction Motor Drive	4-92
Simulating the Induction Motor Drive	4-96
Starting the Drive	4-97
Steady-State Voltage and Current Waveforms	4-97
Speed Regulation Dynamic Performance	4-98
Retune the Drive Parameters	4-100
Modify the Motor Parameters	4-100
Retune the Parameters of the Flux Regulator	4-101
Retune the Parameters of the Speed Regulator	4-107
Retune the Parameters of the DC Bus Voltage	4-111
Simulate and Analyze the Results	4-113
Modify a Drive Block	4-115
Break the Link of the Drive Block	4-115
Modify the Drive Block	4-115
Use the Customized Drive Block	4-117
Simulate the System and Observe the Results	4-119
The GUI of the Modified Drive Block	4-120
Multi-Level Modeling for Rapid Prototyping	4-122
Introduction	4-122
The System Architecture	4-123
The Simplified Model	4-123
The Average-Value Model	4-127
The Detailed Model	4-133
Comparison of the Multi-Level Modeling Precision	4-136
Conclusion	4-141

Series-Compensated Transmission System	5-2
Description of the Transmission System	5-2
Setting the Initial Load Flow and Obtaining Steady State . . .	5-8
Transient Performance for a Line Fault	5-9
Frequency Analysis	5-13
Transient Performance for a Fault at Bus B2	5-16
Thyristor-Based Static Var Compensator	5-19
Introduction	5-19
Description of the SVC	5-19
Steady-State and Dynamic Performance of the SVC	5-23
Misfiring of TSC1	5-25
GTO-Based STATCOM	5-28
Introduction	5-28
Description of the STATCOM	5-29
Steady-State and Dynamic Performance of the STATCOM . .	5-35
Thyristor-Based HVDC Link	5-38
Description of the HVDC Transmission System	5-38
Frequency Response of the AC and DC Systems	5-39
Control and Protection Systems	5-40
System Startup/Stop — Steady-State and Step Response . .	5-44
DC Line Fault	5-51
AC Line-to-Ground Fault at the Inverter	5-53
VSC-Based HVDC Link	5-57
Introduction	5-57
Description of the HVDC Link	5-57
VSC Control System	5-60
Dynamic Performance	5-66

Transient Stability of Power Systems Using Phasor Simulation

6

Improve Transient Stability Using SVC and PSS	6-2
Introduction	6-2
Description of the Transmission System	6-2
Single-Phase Fault — Impact of PSS — No SVC	6-4
Three-Phase Fault — Impact of SVC — PSS in Service	6-6
Control Power Flow Using UPFC and PST	6-8
Introduction	6-8
Description of the Power System	6-8
Power Flow Control with the UPFC	6-11
UPFC P-Q Controllable Region	6-12
Power Flow Control Using a PST	6-13
Wind Farm Using Doubly-Fed Induction Generators	6-18
Description of the Wind Farm	6-18
Turbine Response to a Change in Wind Speed	6-22
Simulation of a Voltage Sag on the 120 kV System	6-24
Simulation of a Fault on the 25 kV System	6-26

Acknowledgments

SimPowerSystems™ First Generation and Specialized Technology software were developed by the following people and organizations.

Gilbert Sybille

Hydro-Québec Research Institute (IREQ), Varennes, Québec. Original author of SimPowerSystems software, technical coordinator, author of the Ideal Switching Solution Method, author of phasor simulation, discretization techniques, and documentation. Technical supervision and design of the FACTS and Renewable Energy libraries, and documentation.

Louis-A. Dessaint

École de Technologie Supérieure (ETS), Montréal, Québec. Author of machine models. Technical supervision and design of the electric drive library contents and documentation.

Bruno DeKelper

École de Technologie Supérieure (ETS), Montréal, Québec. Author of the Ideal Switching Solution Method and author of TLC functions associated with the simulation of the state space equations.

Olivier Tremblay, Jean-Roch Cossa

École de Technologie Supérieure (ETS), Montréal, Québec. Validations and tests of the Ideal Switching Solution Method.

Patrice Brunelle

Hydro-Québec Research Institute (IREQ), Varennes, Québec. Main software engineer. Author of graphical user interfaces, model integration into Simulink® and Physical Modeling, and documentation.

Roger Champagne

École de Technologie Supérieure (ETS), Montréal, Québec. Author of machine models, of revised state space formulation. Design of the graphical user interface of the electric drive library.

Pierre Giroux, Richard Gagnon, Silvano Casoria

Hydro-Québec Research Institute (IREQ), Varennes, Québec. Development of the FACTS and Renewable Energy libraries. Key beta testers and developers of several SimPowerSystems blocks, demos, and documentation.

Hoang Lehuy

Université Laval, Québec City. Validation tests and author of several models, functions, and documentation. Validation of the electric drives library.

Handy Fortin-Blanchette, Olivier Tremblay, Christophe Semaille

École de Technologie Supérieure (ETS), Montréal, Québec. Development of the AC and DC drives models.

Hassan Ouquelle, Jean-Nicolas Paquin

École de Technologie Supérieure (ETS), Montréal, Québec. Development of the Single-Phase Asynchronous Machine model and Saturation in Asynchronous Machine model.

Pierre Mercier

iOMEGAt. Project manager for the Power System Blockset™ software versions 1 and 2 and for the Simulink electric drives library.

The authors acknowledge the contributions of the following people:

Innocent Kamwa, Raymond Roussel, Kamal Al-Haddad, Mohamed Tou, Christian Dufour, Momcilo Gavrilovic, Christian Larose, David McCallum, Bahram Khodabakhchian, Manuel Alvarado Sandoval, and Stéphane Desjardins

Getting Started

- “Product Overview” on page 1-2
- “Build and Simulate a Simple Circuit” on page 1-4
- “Analyze a Simple Circuit” on page 1-12
- “Specify Initial Conditions” on page 1-21
- “Simulating Transients” on page 1-26
- “Introducing the Phasor Simulation Method” on page 1-31

Product Overview

In this section...
“Introduction” on page 1-2
“The Role of Simulation in Design” on page 1-2
“Required and Related Products” on page 1-3

Introduction

SimPowerSystems software and other products of the Physical Modeling product family work together with Simulink software to model electrical, mechanical, and control systems.

SimPowerSystems software operates in the Simulink environment. Therefore, before starting this user's guide, make yourself familiar with Simulink documentation.

The Role of Simulation in Design

Electrical power systems are combinations of electrical circuits and electromechanical devices like motors and generators. Engineers working in this discipline are constantly improving the performance of the systems. Requirements for drastically increased efficiency have forced power system designers to use power electronic devices and sophisticated control system concepts that tax traditional analysis tools and techniques. Further complicating the analyst's role is the fact that the system is often so nonlinear that the only way to understand it is through simulation.

Land-based power generation from hydroelectric, steam, or other devices is not the only use of power systems. A common attribute of these systems is their use of power electronics and control systems to achieve their performance objectives.

SimPowerSystems software is a modern design tool that allows scientists and engineers to rapidly and easily build models that simulate power systems. It uses the Simulink environment, allowing you to build a model using simple *click and drag* procedures. Not only can you draw the circuit topology rapidly, but your analysis of the circuit can include its interactions with mechanical, thermal, control, and other disciplines. This is possible because all the electrical parts of the simulation interact with the extensive Simulink modeling library. Since Simulink uses the MATLAB[®] computational engine, designers can also use MATLAB toolboxes and Simulink blocksets. SimPowerSystems software

belongs to the Physical Modeling product family and uses similar block and connection line interface.

Required and Related Products

SimPowerSystems software requires the following products:

- MATLAB
- Simulink
- Simscape™

In addition to SimPowerSystems software, the Physical Modeling product family includes other products for modeling and simulating mechanical and electrical systems. Use these products together to model physical systems in Simulink and Simscape environment. There are also a number of closely related products from MathWorks that you can use with SimPowerSystems software. For more information about any of these products, see the MathWorks website at <http://www.mathworks.com>; see the “Products” section.

Build and Simulate a Simple Circuit

In this section...
“Introduction” on page 1-4
“Building the Electrical Circuit with the SimPowerSystems Specialized Technology Library” on page 1-5
“Interfacing the Electrical Circuit with Other Simulink Blocks” on page 1-9
“Measuring Voltages and Currents” on page 1-10
“Basic Principles of Connecting Capacitors and Inductors” on page 1-10
“Using the Powergui Block to Simulate SimPowerSystems Models” on page 1-11

Introduction

SimPowerSystems Specialized Technology allows you to build and simulate electrical circuits containing linear and nonlinear elements.

In this section you

- Explore the SimPowerSystems Specialized Technology library
- Learn how to build a simple circuit from the SimPowerSystems Specialized Technology library
- Interconnect Simulink blocks with your circuit

The circuit below represents an equivalent power system feeding a 300 km transmission line. The line is compensated by a shunt inductor at its receiving end. A circuit breaker allows energizing and de-energizing of the line. To simplify matters, only one of the three phases is represented. The parameters shown in the figure are typical of a 735 kV power system.

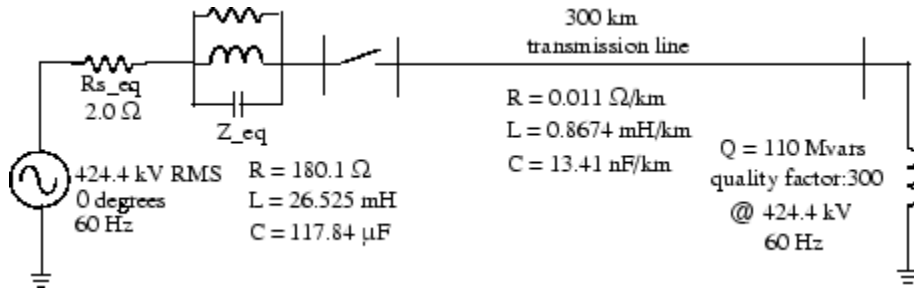

Circuit to Be Modeled

Building the Electrical Circuit with the SimPowerSystems Specialized Technology Library

The graphical user interface makes use of the Simulink functionality to interconnect various electrical components. The electrical components are grouped in the SimPowerSystems Specialized Technology library.

- 1 Open the SimPowerSystems main library by entering the following command at the MATLAB prompt.

```
simpowersystems_ST
```
- 2 From the **File** menu of the **simpowersystems_ST** window, open a new window to contain your first circuit and save it as **circuit1**.
- 3 Open the Fundamental Blocks > Electrical Sources library and copy the **AC Voltage Source** block into the **circuit1** window.
- 4 Open the **AC Voltage Source** dialog box by double-clicking the icon and enter the Amplitude, Phase, and Frequency parameters according to the values shown in Circuit to Be Modeled.

Note that the amplitude to be specified for a sinusoidal source is its peak value ($424.4e3 \cdot \sqrt{2}$ volts in this case).

- 5 Change the name of this block from AC Voltage Source to **Vs**.
- 6 Copy the **Parallel RLC Branch** block, which can be found in the Fundamental Blocks/Elements library, set its parameters as shown in Circuit to Be Modeled, and name it **Z_eq**.
- 7 The resistance **Rs_eq** of the circuit can be obtained from the Parallel RLC Branch block. Duplicate the Parallel RLC Branch block, which is already in your **circuit1**

window. Select R for the Branch Type parameter and set the R parameter according to Circuit to Be Modeled.

Once the dialog box is closed, notice that the L and C components have disappeared so that the icon now shows a single resistor.

- 8 Name this block Rs_eq.
- 9 Resize the various components and interconnect blocks by dragging lines from outputs to inputs of appropriate blocks.

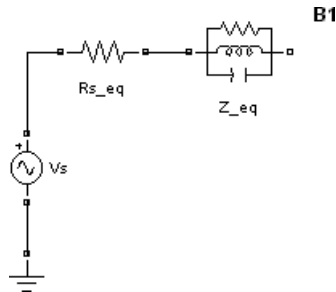

- 10 To complete the circuit of Circuit to Be Modeled, you need to add a transmission line and a shunt reactor. You add the circuit breaker later in “Simulating Transients” on page 1-26.

The model of a line with uniformly distributed R, L, and C parameters normally consists of a delay equal to the wave propagation time along the line. This model cannot be simulated as a linear system because a delay corresponds to an infinite number of states. However, a good approximation of the line with a finite number of states can be obtained by cascading several PI circuits, each representing a small section of the line.

A PI section consists of a series R-L branch and two shunt C branches. The model accuracy depends on the number of PI sections used for the model. Copy the **PI Section Line** block from the Elements library into the **circuit1** window, set its parameters as shown in Circuit to Be Modeled, and specify one line section.

- 11 The shunt reactor is modeled by a resistor in series with an inductor. You could use a **Series RLC Branch** block to model the shunt reactor, but then you would have to manually calculate and set the R and L values from the quality factor and reactive power specified in Circuit to Be Modeled.

Therefore, you might find it more convenient to use a **Series RLC Load** block that allows you to specify directly the active and reactive powers absorbed by the shunt reactor.

Copy the **Series RLC Load** block, which can be found in the **Fundamental Blocks/Elements** library. Name this block **110 Mvar**. Set its parameters as follows:

Vn	424.4e3 V
fn	60 Hz
P	110e6/300 W (quality factor = 300)
QL	110e6 vars
Qc	0

Note that, as no reactive capacitive power is specified, the capacitor disappears on the block icon when the dialog box is closed. Interconnect the new blocks as shown.

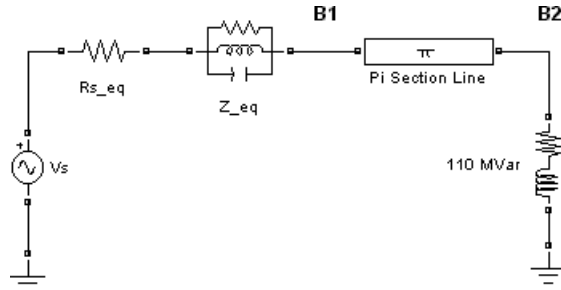

- 12** You need a **Voltage Measurement** block to measure the voltage at node **B1**. This block is found in the **Fundamental Blocks/Measurements** library. Copy it and name it **U1**. Connect its positive input to the node **B1** and its negative input to a new **Ground** block.
- 13** To observe the voltage measured by the **Voltage Measurement** block named **U1**, a display system is needed. This can be any device found in the **Simulink Sinks** library.

Open the **Sinks** library and copy the **Scope** block into your **circuit1** window. If the scope were connected directly at the output of the voltage measurement, it would display the voltage in volts. However, electrical engineers in power systems are used to working with normalized quantities (per unit system). The voltage is normalized

by dividing the value in volts by a base voltage corresponding to the peak value of the system nominal voltage. In this case the scaling factor K is

$$K = \frac{1}{424.4 \times 10^3 \times \sqrt{2}}$$

- 14** Copy a Gain block from the Simulink library and set its gain as above. Connect its output to the Scope block and connect the output of the Voltage Measurement block to the Gain block. Duplicate this voltage measurement system at the node B2, as shown below.

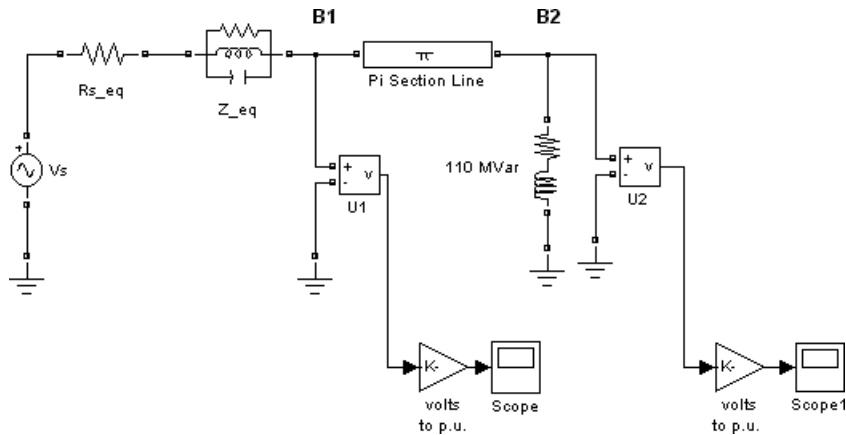

- 15** Add a Powergui block to your model. The purpose of this block is discussed in “Using the Powergui Block to Simulate SimPowerSystems Models” on page 1-11.
- 16** Select **Simulation > Run**.
- 17** Open the Scope blocks and observe the voltages at nodes B1 and B2.
- 18** While the simulation is running, open the Vs block dialog box and modify the amplitude. Observe the effect on the two scopes. You can also modify the frequency and the phase. You can zoom in on the waveforms in the scope windows by drawing a box around the region of interest with the left mouse button.

To simulate this circuit, the default integration algorithm (ode45) was used. However, for most SimPowerSystems applications, your circuits contain switches and other nonlinear models. In such a case, you must specify a different integration algorithm. This is discussed in “Simulating Transients” on page 1-26, where a circuit breaker is added to your circuit.

Interfacing the Electrical Circuit with Other Simulink Blocks

The Voltage Measurement block acts as an interface between the SimPowerSystems blocks and the Simulink blocks. For the system shown above, you implemented such an interface from the electrical system to the Simulink system. The Voltage Measurement block converts the measured voltages into Simulink signals.

Similarly, the Current Measurement block from the Fundamental Blocks/Measurements library can be used to convert any measured current into a Simulink signal.

You can also interface from Simulink blocks to the electrical system. For example, you can use the Controlled Voltage Source block to inject a voltage in an electrical circuit, as shown in the following figure.

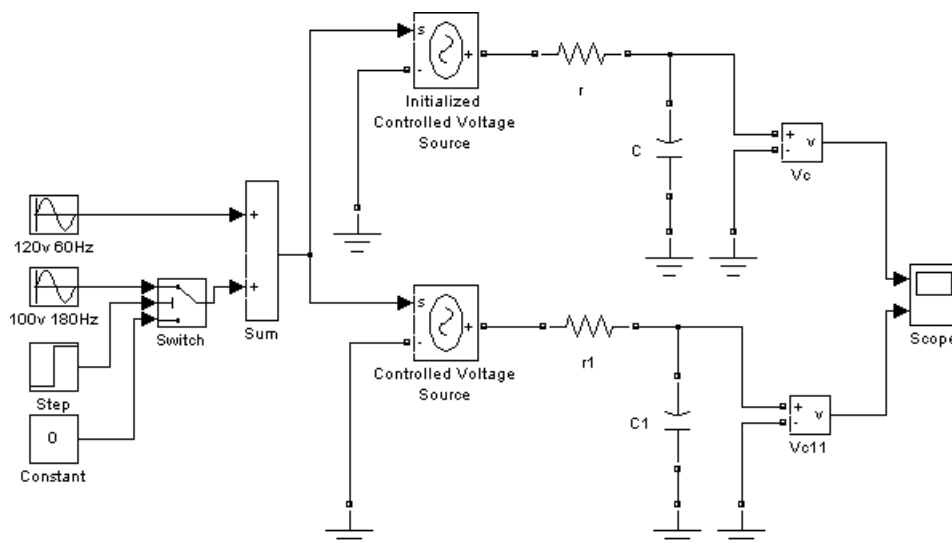

Electrical Terminal Ports and Connection Lines SimPowerSystems modeling environment is similar to that of other products in the Physical Modeling family. Its blocks often feature both normal Simulink input and output ports > and special electrical terminal ports □:

- Lines that connect normal Simulink ports > are directional signal lines.

- Lines that connect terminal ports □ are special electrical connection lines. These lines are nondirectional and can be branched, but you cannot connect them to Simulink ports > or to normal Simulink signal lines.
- You can connect Simulink ports > only to other Simulink ports and electrical terminal ports □ only to other electrical terminal ports.
- Converting Simulink signals to electrical connections or vice versa requires using a SimPowerSystems block that features both Simulink ports and electrical terminal ports.

Some SimPowerSystems blocks feature only one type of port.

Measuring Voltages and Currents

When you measure a current using a **Current Measurement** block, the positive direction of current is indicated on the block icon (positive current flowing from + terminal to – terminal). Similarly, when you measure a voltage using a **Voltage Measurement** block, the measured voltage is the voltage of the + terminal with respect to the – terminal.

Basic Principles of Connecting Capacitors and Inductors

You have to pay particular attention when you connect capacitor elements together with voltage sources, or inductor elements in series with current sources. When you start the simulation, the software displays an error message if one of the following two connection errors are present in your diagram:

- 1 You have connected a voltage source in parallel with a capacitor, or a series of capacitor elements in series, like in the two examples below.

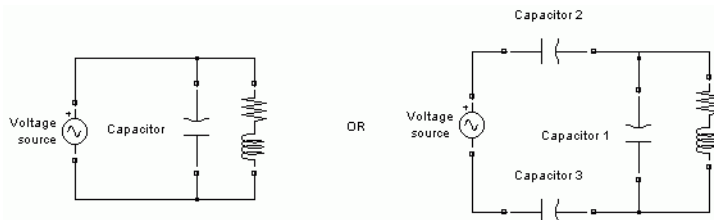

To fix this problem, you can add a small resistance in series between the voltage source and the capacitors.

- 2 You have connected a current source in series with an inductor, or a series of inductors connected in parallel, like in the example below.

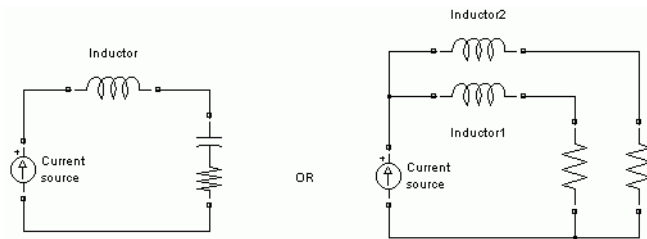

To fix this problem, you can add a large resistance in parallel with the inductor.

Using the Powergui Block to Simulate SimPowerSystems Models

The Powergui block is necessary for simulation of any Simulink model containing SimPowerSystems blocks. It is used to store the equivalent Simulink circuit that represents the state-space equations of the SimPowerSystems blocks.

See `powergui` for more information on how to use the powergui block in your models.

Note When you start the simulation, you will get an error if no Powergui block is found in your model.

Analyze a Simple Circuit

In this section...
“Introduction” on page 1-12
“Electrical State Variables” on page 1-12
“State-Space Representation Using power_analyze” on page 1-12
“Steady-State Analysis” on page 1-13
“Frequency Analysis” on page 1-14

Introduction

In this section you

- Obtain the state-space representation of your model with the `power_analyze` command
- Compute the steady-state voltages and currents using the graphical user interface of the Powergui block
- Analyze an electrical circuit in the frequency domain

Electrical State Variables

The electrical state variables are the Simulink states of your diagram associated to the capacitor and inductor devices of the SimPowerSystems blocks. Inductors and capacitors elements are found in the RLC-branch type blocks such as the Series RLC Branch block, Three-Phase Parallel RLC Load block, in the transformer models, in the PI Section Line block, in the snubber devices of the power electronic devices, etc.

The electrical state variables consist of the inductor currents and the capacitor voltages. Variable names for SimPowerSystems electrical states contain the name of the block where the inductor or capacitor is found, preceded by the `Il_` prefix for inductor currents or the `Uc_` prefix for capacitor voltages.

State-Space Representation Using `power_analyze`

You compute the state-space representation of a model with the `power_analyze` command. Enter the following command at the MATLAB prompt.

```
[A,B,C,D,x0,electrical_states,inputs,outputs]=power_analyze('power_gui')
```

The `power_analyze` command returns the state-space model of `power_gui` example model in the four matrices A, B, C, and D. `x0` is the vector of initial conditions of the electrical states of your circuit. The names of the electrical state variables, inputs, and outputs are returned in three string matrices.

See the `power_analyze` reference page for more details on how to use this function.

Steady-State Analysis

Open the `power_gui` example model by typing `power_gui` at the command line. In the Powergui block, in the **Tools** tab, select **Steady-State**. This opens the **Powergui Steady-State Voltages and Currents Tool** window where the steady-state phasors voltages measured by the voltage measurement and current measurement blocks of the model are displayed in polar form.

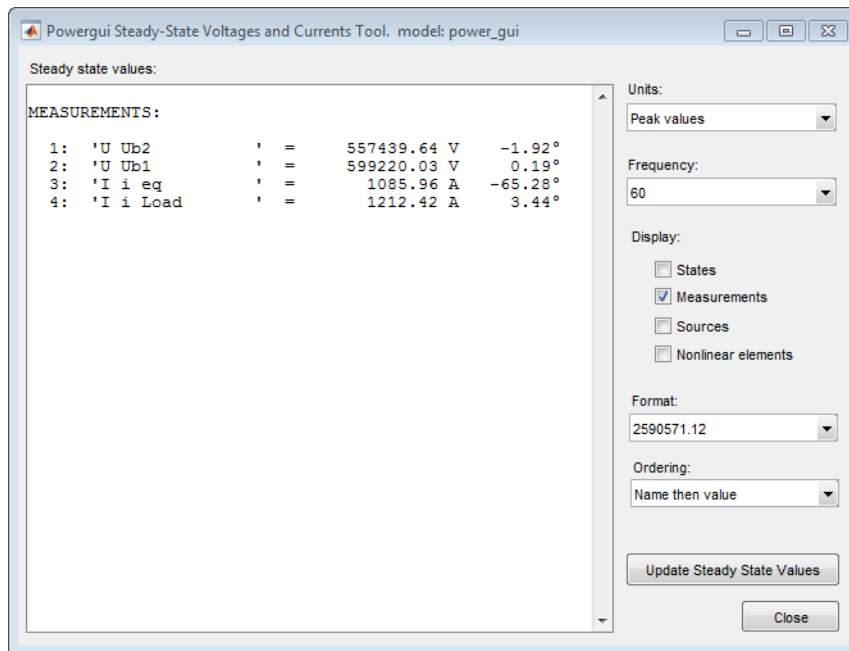

Each measurement output is identified by a string corresponding to the measurement block name. The magnitudes of the phasors correspond to the peak value of the sinusoidal voltages.

From the **Powergui Steady-State Voltages and Currents Tool** window, you can also display the steady-state values of the source voltage or the steady-state values of the inductor currents and capacitor voltages by selecting either the **Sources** or the **States** check box.

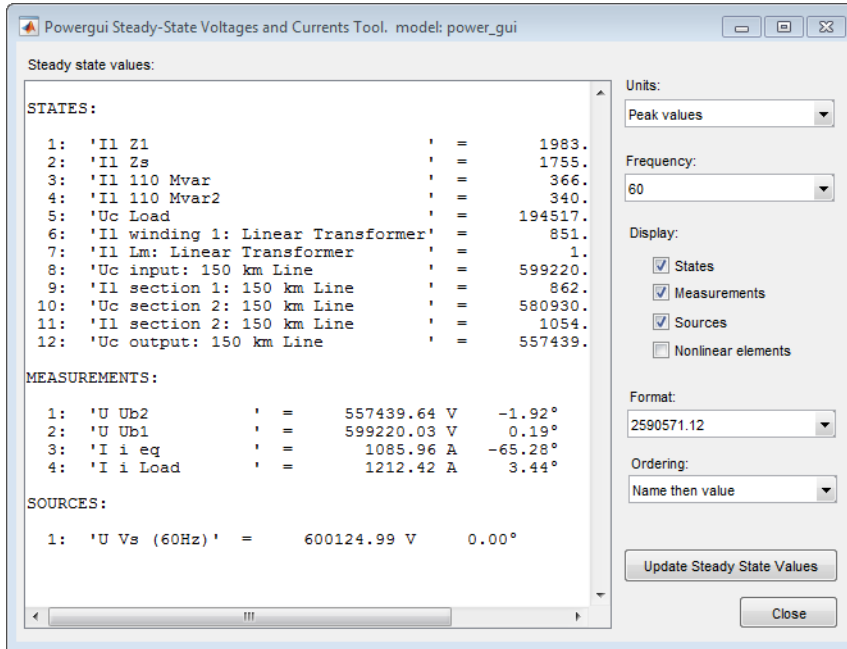

Refer to the section “Measuring Voltages and Currents” on page 1-10 for more details on the sign conventions used for the voltages and currents of sources and electrical state variables listed in the **Steady-State Tool** window.

Frequency Analysis

The Fundamental Blocks/Measurements library contains an **Impedance Measurement** block that measures the impedance between any two nodes of a circuit. In the following two sections, you measure the impedance in the power_gui model by using two methods:

- Automatic measurement using the Impedance Measurement block and the Powergui block
- Calculation from the state-space model

Obtaining the Impedance vs. Frequency Relation from the Impedance Measurement and Powergui Blocks

The process to measure a circuit impedance from the state-space model (which is described in detail in the next section, “Obtaining the Impedance vs. Frequency Relation from the State-Space Model” on page 1-17) has been automated in a SimPowerSystems block. In the power_gui example model, two Impedance Measurement blocks of powerlib measure impedance at two points in the model. Delete the Impedance B3 block and reconnect the Impedance B1 as shown.

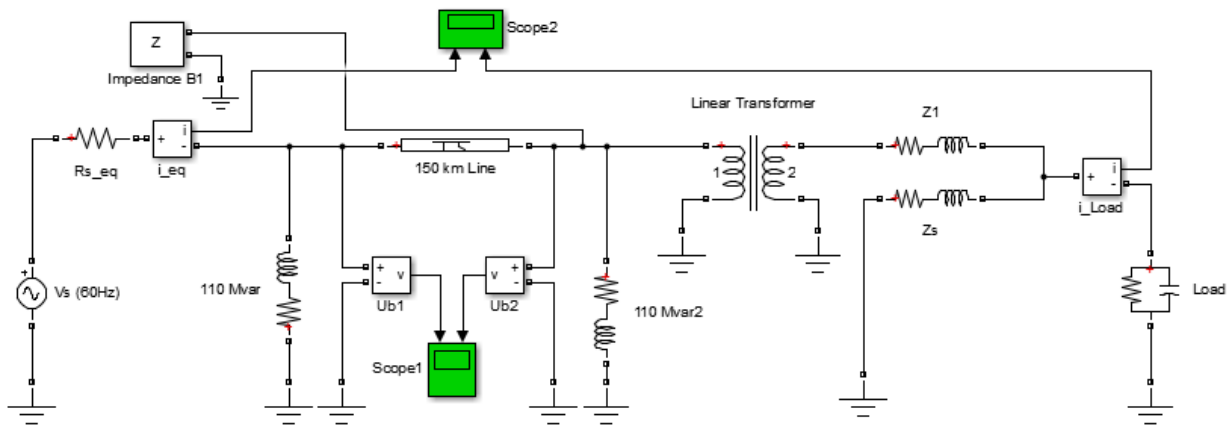

Measuring Impedance vs. Frequency with the Impedance Measurement Block

In the 150km line block, set **Number of pi sections** to 1, and click **OK**. Open the Powergui dialog. In the **Tools** tab, select **Impedance Measurement**. A new window opens, showing the list of Impedance Measurement blocks available in the circuit.

Fill in the frequency range by entering **0:2:5000** (zero to 5000 Hz by steps of 2 Hz). Select the logarithmic scale to display **Z** magnitude.

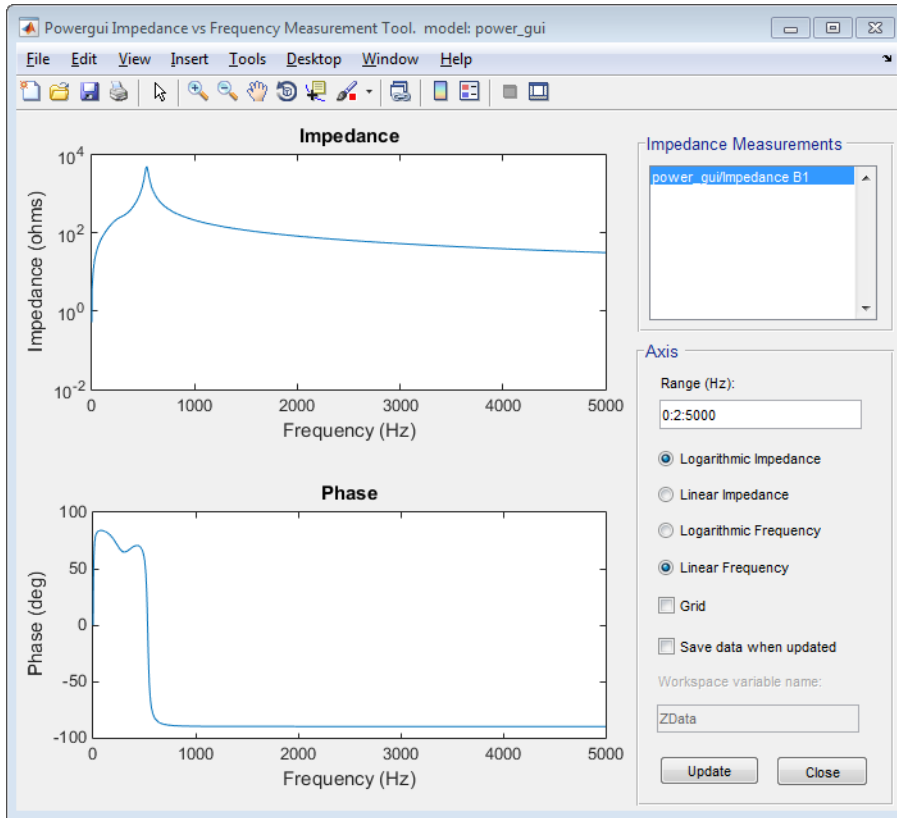

When the calculation is finished, the window displays the magnitude and phase as functions of frequency. In the 150 km line block dialog box, set the **Number of pi sections** to 10. In the Powergui Impedance vs Frequency Measurement tool, click the **Update** button. The dialog box displays the frequency response for the new circuit.

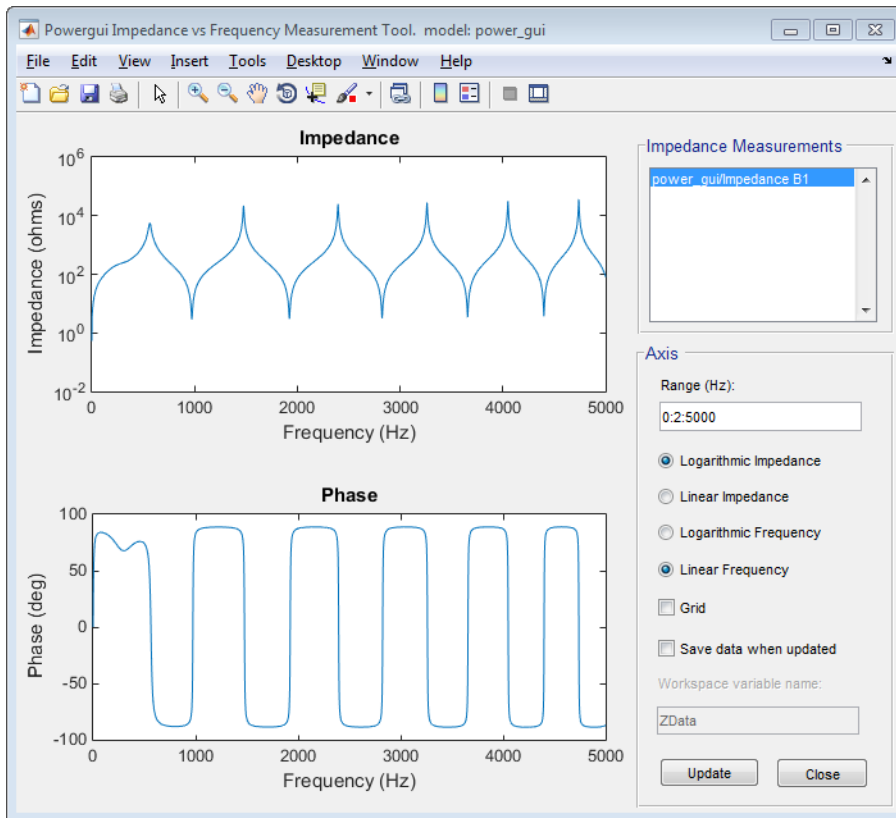

Obtaining the Impedance vs. Frequency Relation from the State-Space Model

Note The following section assumes you have Control System Toolbox™ software installed.

To measure the impedance versus frequency at the same node where the impedance measurement block is connected, you need a current source providing a second input to the state-space model. Open the Electrical Sources library and copy the AC Current Source block into your model. Connect this source, as shown below. Set the current source magnitude to zero and keep its frequency at 60 Hz.

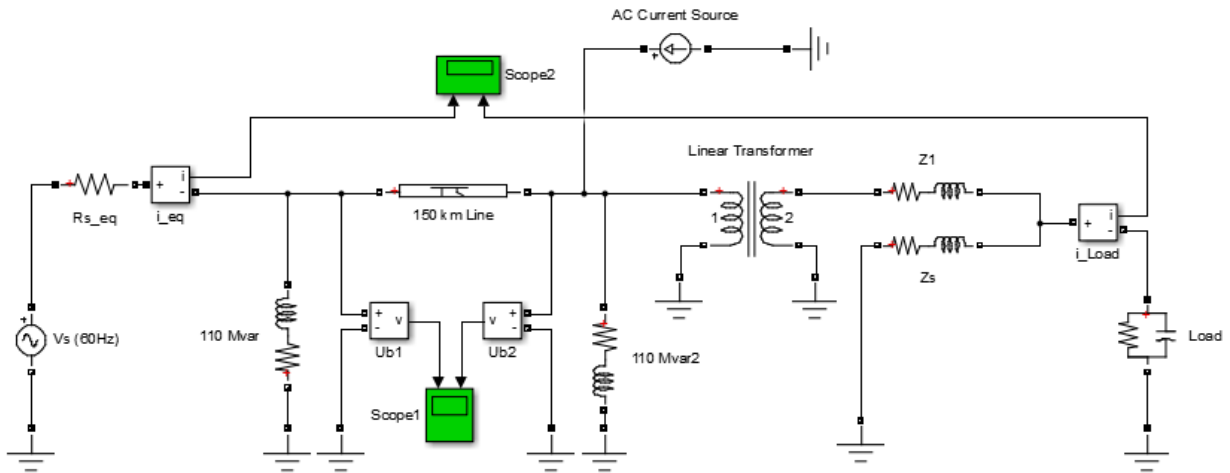

AC Current Source at the B2 Node

Now compute the state-space representation of the model with the `power_analyze` command. Enter the following command at the MATLAB prompt.

```
sys1 = power_analyze('power_gui', 'ss')
```

This command returns a state-space model representing the continuous-time state-space model of your electrical circuit.

In the Laplace domain, the impedance is defined as the transfer function between the current injected by the AC current Source block and the voltage measured by the U2 Voltage Measurement block.

$$Z2(s) = \frac{U2(s)}{I2(s)}$$

You obtain the names of the inputs and outputs of this state-space model as follows.

```
sys1.InputName
ans =
    'U_Vs (60Hz)'
    'I_AC Current Source'
```



```
sys1.OutputName
ans =
    'U_Ub2'
    'U_Ub1'
```

The impedance at the measured node then corresponds to the transfer function between output 1 and input 2 of this state-space model. For the 0 to 5000 Hz range, it can be calculated and displayed as follows.

```
freq=0:5000;
w=2*pi*freq;
bode(sys1(1,2),w);
```

Repeat the same process to get the frequency response with a 10 section line model. Open the **PI Section Line** dialog box and change the number of sections from 1 to 10. To calculate the new frequency response and superimpose it upon the one obtained with a single line section, enter the following commands.

```
sys10 = power_analyze('power_gui','ss');
bode(sys1(1,2),sys10(1,2),w);
```

Open the property editor of the Bode plot and select units for Frequency in Hz using linear scale and Magnitude in absolute using log scale. The resulting plot is shown below.

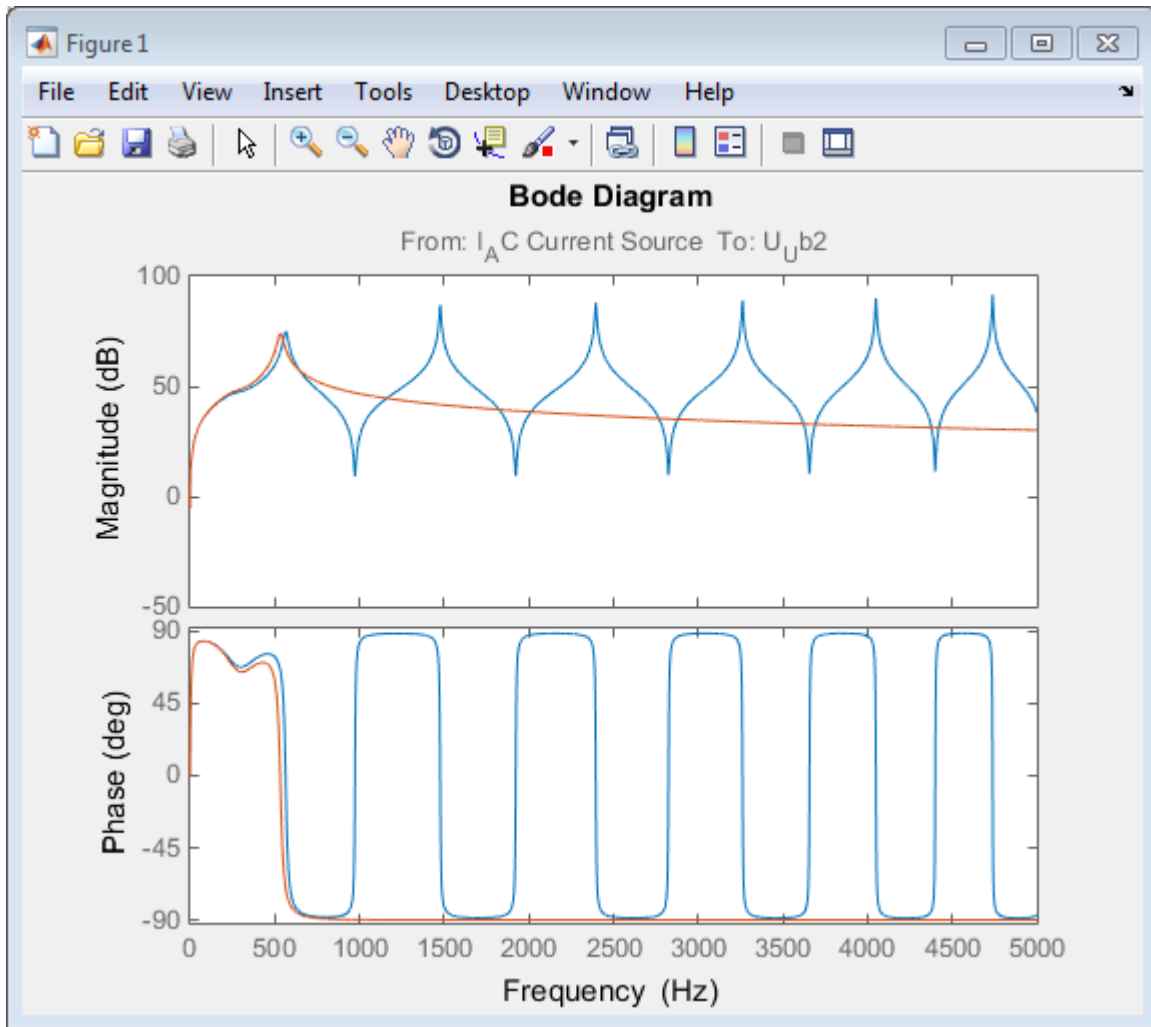

Impedance at the Measured Node as Function of Frequency

This graph indicates that the frequency range represented by the single line section model is limited and the 10 line section model gives a better approximation for higher frequencies.

Specify Initial Conditions

In this section...

“Introduction” on page 1-21

“State Variables” on page 1-21

“Initial States” on page 1-22

“Specify Initial Electrical States with Powergui” on page 1-23

Introduction

In this section you

- Learn what are the state variables of a Simulink diagram containing SimPowerSystems blocks
- Specify initial conditions for the electrical state variables

State Variables

The state variables of a Simulink diagram containing SimPowerSystems blocks consist of

- The electrical states associated to RLC branch-type SimPowerSystems blocks. They are defined by the state-space representation of your model. See “Electrical State Variables” on page 1-12 for more details about the electrical states.
- The Simulink states of the SimPowerSystems electrical models such as the Synchronous Machine block, the Saturable Transformer block, or the Three-Phase Dynamic Load block.
- The Simulink states of the other Simulink blocks of your model (controls, user-defined blocks, and other blocksets).

The following picture provides an example that contains the three types of state variables:

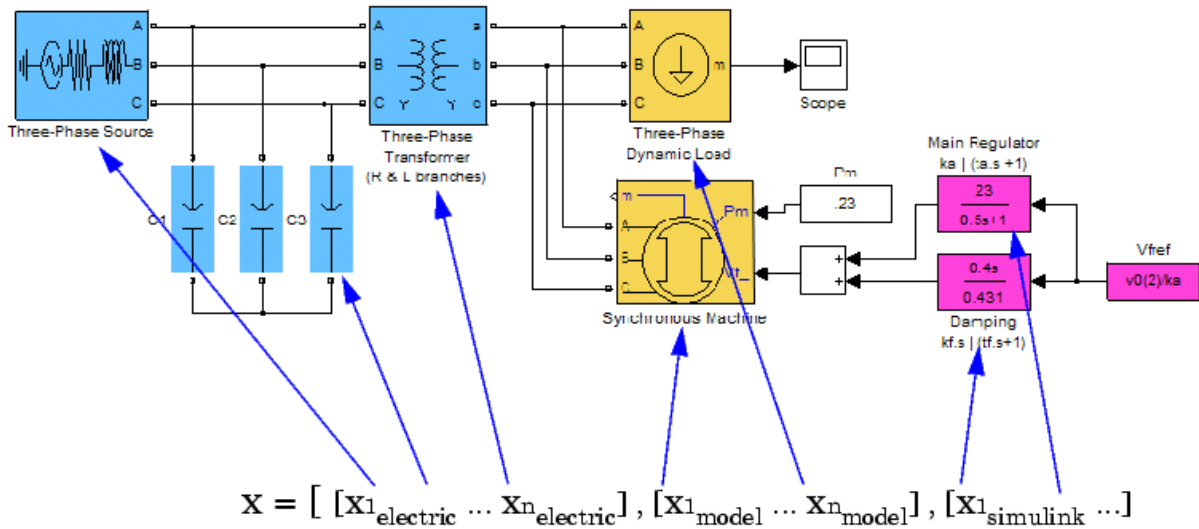

Initial States

Initial conditions, which are applied to the entire system at the start of the simulation, are generally set in the blocks. Most of the Simulink blocks allow you to specify initial conditions. For the case of the electrical states, the SimPowerSystems software automatically sets the initial values of the electrical states to start the simulation in steady state.

However, you can specify the initial conditions for the capacitor voltage and inductor currents in the mask of these blocks:

- the Series and Parallel RLC Branch blocks
- the Series and Parallel RLC Load blocks

The initial values entered in the mask of these block will overwrite the default steady-state parameters calculated by the SimPowerSystems software. In the same sense, you can overwrite initial conditions of the overall blocks by specifying them in the **States** area of the **Model Configuration Parameters** dialog box.

See the `power_init` function reference page for more details on how you can specify initial states for a Simulink diagram with SimPowerSystems blocks.

Specify Initial Electrical States with Powergui

- 1 Open the Transient Analysis of a Linear Circuit example by typing `power_transient` at the command line. Rename the RLC Branch blocks as shown in the next figure.

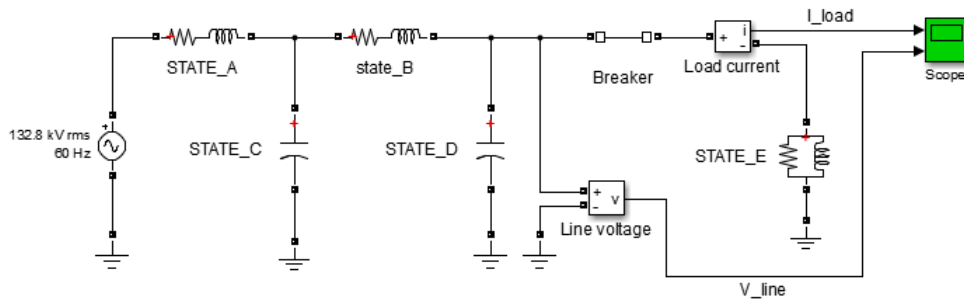

- 2 From the **Tools** tab of the Powergui block, select **Initial State**. The initial values of the five electrical state variables (three inductor currents and two capacitor voltages) are displayed. These initial values corresponds to the values that the software automatically sets to start the simulation in steady state.

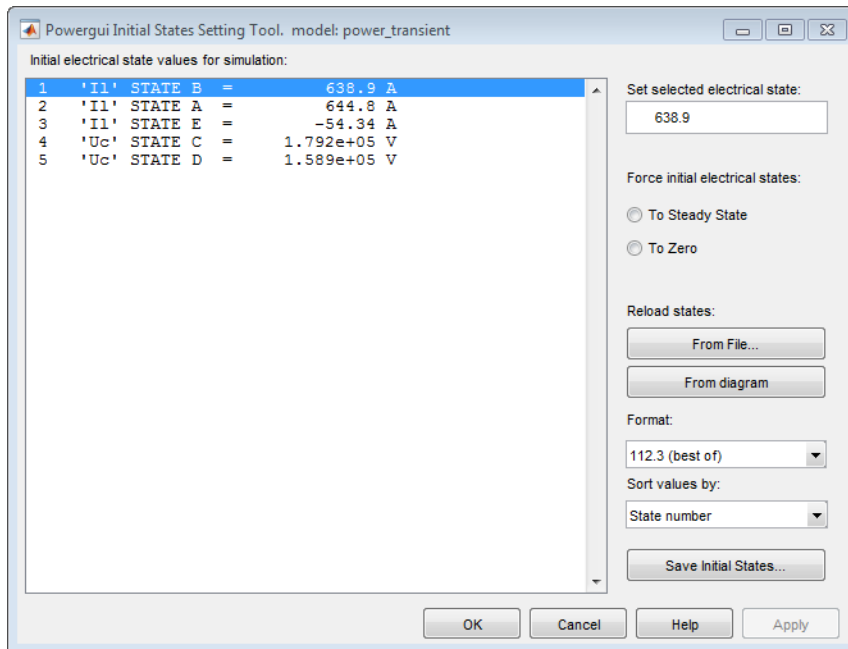

- 3 Open the Scope block and start the simulation. As the electrical state variables are automatically initialized, the system starts in steady state and sinusoidal waveforms are observed.
- 4 The initial value for STATE_D state is set to 1.589e5 V. It corresponds to the initial capacitor voltage found in the STATE_D block. Open this block, select the **Set the initial capacitor voltage** parameter, then specify a capacitor initial voltage of -2e5 V. Click the **OK** button.
- 5 Click the **From diagram** button of the Powergui Initial States Tool to refresh the display of initial states. The initial state of STATE_D block is now set to -2e5 V.
- 6 Start the simulation. In the second trace of the Scope block, zoom around the transient at the beginning of the simulation. As expected, the model does not start in steady state, but the initial value for the capacitor voltage measured by the Voltage Measurement block is -2e5 V.
- 7 Select the STATE_A state variable in the **Initial States Tool** list. In the **Set selected electrical state** field, set the initial inductor current to 50 A, and click **Apply**. Open the mask of the STATE_A block, and note that the **Set the initial**

inductor current parameter is selected and the initial inductor current is set to 50 A.

Run the simulation and observe the new transient caused by this new setting.

Forcing Initial States to Zero

Now suppose that you want to reset all the initial electrical states to zero without losing the settings you have done in the previous steps.

- 1 From the Initial State Tool window, select the **To zero** check box under **Force initial electrical states**, then click **Apply**. Restart the simulation and observe the transient when all the initial conditions starts from zero.
- 2 Open the masks of the STATE_C and STATE_A blocks and note that even if initial conditions are still specified in these blocks, the setting for the initial states is forced to zero by the Powergui block.

A message is displayed at the command line to remind you every time you start the simulation that the electrical initial states of your model are forced to zero by the Powergui block, which overwrites the block settings in your model.

Forcing Initial States to Steady State

Similarly, you can set all the initial states to steady without losing the settings you have done in the previous steps.

- 1 From the Initial State Tool window, select the **To steady state** check box under **Force initial electrical states**, then click **Apply**.
- 2 Restart the simulation and observe that the simulation starts in steady state.

A message is displayed at the command line to remind you every time you start the simulation that the electrical initial states of your model are forced to steady state by the Powergui block.

Returning to Block Settings

To return to the block settings, clear both check boxes under **Force initial electrical states**, then click **Apply**.

Simulating Transients

In this section...

“Introduction” on page 1-26

“Simulating Transients with a Circuit Breaker” on page 1-26

“Discretizing the Electrical System” on page 1-28

Introduction

In this section you

- Learn how to create an electrical subsystem
- Simulate transients with a circuit breaker
- Compare time domain simulation results with different line models
- Learn how to discretize a circuit and compare results thus obtained with results from a continuous, variable time step algorithm

Simulating Transients with a Circuit Breaker

One of the main uses of SimPowerSystems software is to simulate transients in electrical circuits. This can be done with either mechanical switches (circuit breakers) or switches using power electronic devices.

- 1 Open the power_gui example model.
- 2 Insert a circuit breaker into your circuit to simulate a line energization by opening the Fundamental Blocks/Elements library. Copy the **Breaker** block into the power_gui example.
- 3 Open the Breaker block dialog box and set its parameters as follows:

Ron	0.001 Ω
Initial status	0 (open)
Rs	inf
Cs	0

Switching times	$[(1/60)/4]$
------------------------	--------------

- 4 Insert the circuit breaker in series with the sending end of the line, then rearrange the circuit as shown in the figure.
- 5 Right-click the two lines that connect to the Scope 1 block and select Properties. In the dialog box, select **Log signal data** for the two signals and click **OK**. From the Simulation Data Inspector menu  , select **Send Logged Workspace Data to Data Inspector**.
- 6 Open the **PI section Line** dialog box and make sure the number of sections is set to 1. Start the simulation.
- 7 Open the **PI section Line** dialog box and change the number of sections from 1 to 10. Start the simulation.
- 8 Delete the PI section line model and replace it with a single-phase **Distributed Parameter Line** block. Set the number of phases to 1 and use the same R, L, C, and length parameters as for the PI section line. Start the simulation.
- 9 You can now compare the three waveforms obtained with the three line models. Open the Simulation Data Inspector. Select the Ub1 and Ub2 signals of Run 1, the Ub2 signals of Run 2, and Run 3.

A zoom on these waveforms is shown in the next figure. As expected from the frequency analysis performed during “Analyze a Simple Circuit” on page 1-12, the single PI model does not respond to frequencies higher than 229 Hz. The 10 PI section model gives a better accuracy, although high-frequency oscillations are introduced by the discretization of the line. You can clearly see in the figure the propagation time delay of 1.03 ms associated with the distributed parameter line.

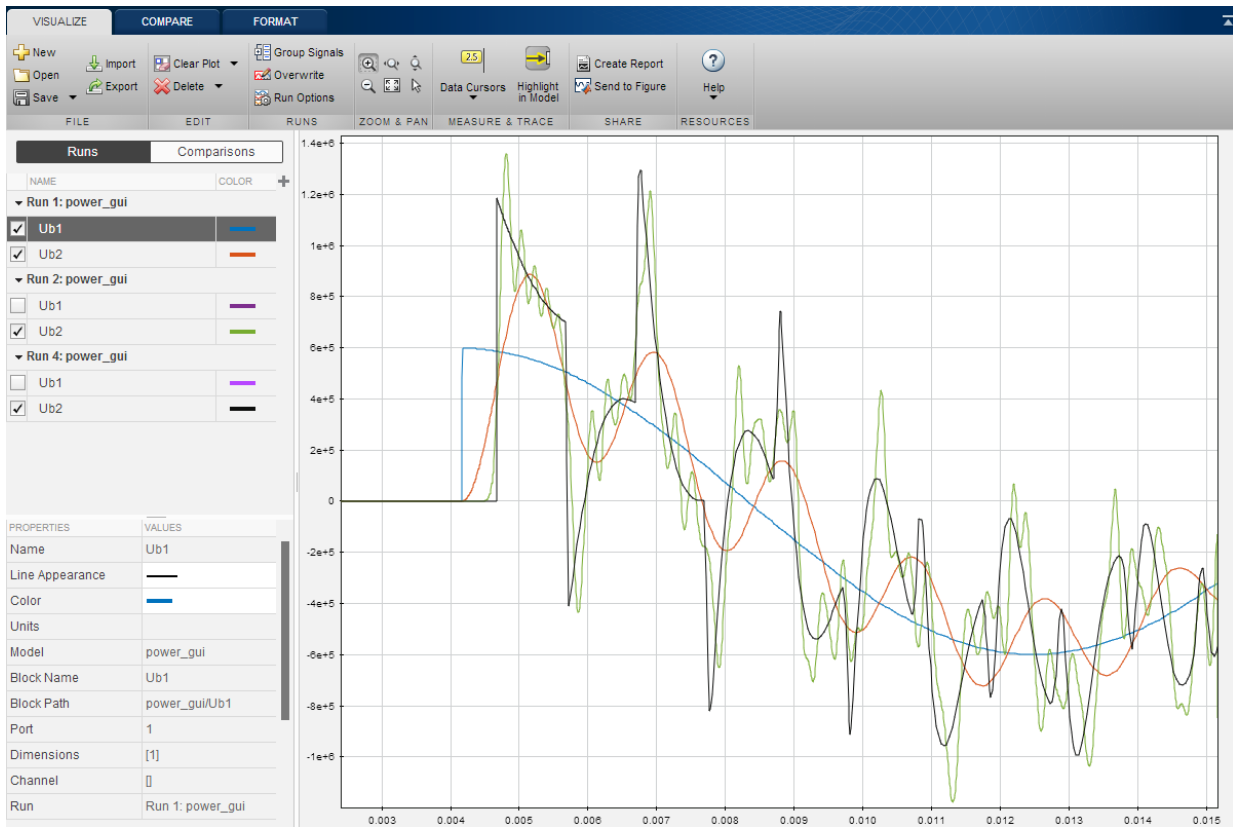

Receiving End Voltage Obtained with Three Different Line Models

Discretizing the Electrical System

An important product feature is its ability to simulate either with continuous, variable step integration algorithms or with discrete solvers. For small systems, variable time step algorithms are usually faster than fixed step methods, because the number of integration steps is lower. For large systems that contain many states or many nonlinear blocks such as power electronic switches, however, it is advantageous to discretize the electrical system.

When you discretize your system, the precision of the simulation is controlled by the time step. If you use too large a time step, the precision might not be sufficient. The only

way to know if it is acceptable is to repeat the simulation with different time steps and find a compromise for the largest acceptable time step. Usually time steps of 20 μs to 50 μs give good results for simulation of switching transients on 50 Hz or 60 Hz power systems or on systems using line-commutated power electronic devices such as diodes and thyristors. You must reduce the time step for systems using forced-commutated power electronic switches. These devices, the insulated-gate bipolar transistor (IGBT), the field-effect transistor (FET), and the gate-turnoff thyristor (GTO) are operating at high switching frequencies.

For example, simulating a pulse-width-modulated (PWM) inverter operating at 8 kHz would require a time step of at most 1 μs .

- 1** Open the `power_3level` example. In the Powergui block, note that the **Simulation type** is set to **Discrete** and the **sample time** is set to 1e-6 s by the `Ts` variable defined in the Model Properties. Run a first simulation.
- 2** To perform a continuous simulation, open the Powergui block parameters dialog box and set **Simulation type** to **Continuous**. Select **Use ideal switching devices**. Select the `ode23tb` variable-step solver in the Configuration Parameters dialog box. Simulate the model.
- 3** In the Powergui block, set **Simulation type** to **Discrete**. In the command window, specify `Ts = 20e-6`. Run the simulation.
- 4** Open the Simulation Data Inspector and compare the differences on the high-frequency transients.

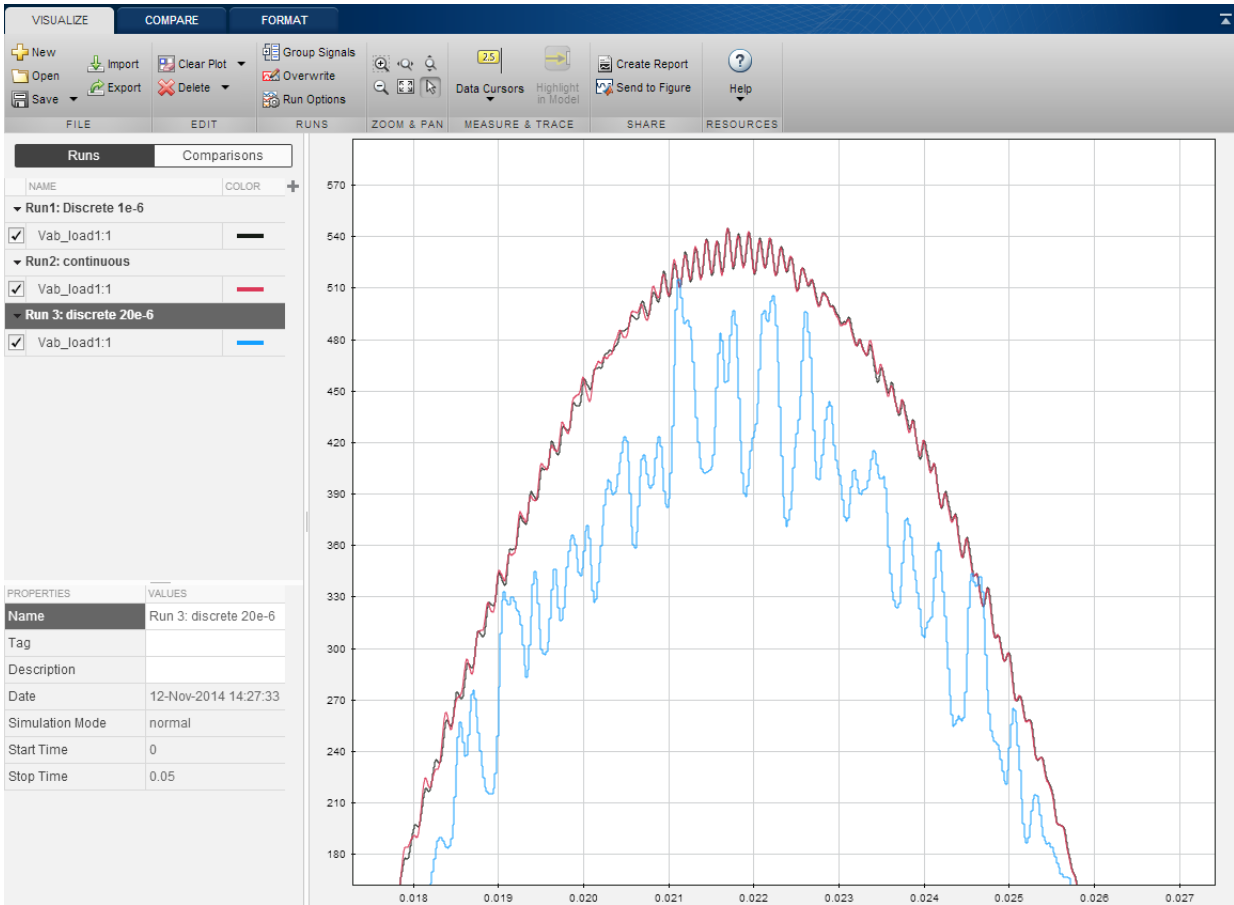

The $1 \mu\text{s}$ compares reasonably well with the continuous simulation. However, increasing the time step to $20 \mu\text{s}$ produces appreciable errors. The μs time step would therefore be acceptable for this circuit, while obtaining a gain on simulation speed.

Introducing the Phasor Simulation Method

In this section...

“Introduction” on page 1-31

“When to Use the Phasor Solution” on page 1-31

“Phasor Simulation of a Circuit Transient” on page 1-32

Introduction

In this section, you

- Apply the phasor simulation method to a simple linear circuit
- Learn advantages and limitations of this method

Up to now you have used two methods to simulate electrical circuits:

- Simulation with variable time steps using the continuous Simulink solvers
- Simulation with fixed time steps using a discretized system

This section explains how to use a third simulation method, the phasor solution method.

When to Use the Phasor Solution

The phasor solution method is mainly used to study electromechanical oscillations of power systems consisting of large generators and motors. An example of this method is the simulation of a multimachine system in “Three-Phase Systems and Machines” on page 2-22. However, this technique is not restricted to the study of transient stability of machines. It can be applied to any linear system.

If, in a linear circuit, you are interested only in the changes in magnitude and phase of all voltages and currents when switches are closed or opened, you do not need to solve all differential equations (state-space model) resulting from the interaction of R, L, and C elements. You can instead solve a much simpler set of algebraic equations relating the voltage and current phasors. This is what the phasor solution method does. As its name implies, this method computes voltages and currents as phasors. Phasors are complex numbers representing sinusoidal voltages and currents at a particular frequency. They can be expressed either in Cartesian coordinates (real and imaginary) or in polar coordinates (amplitude and phase). As the electrical states are ignored, the phasor solution method does not require a particular solver to solve the electrical part of

your system. The simulation is therefore much faster to execute. You must keep in mind, however, that this faster solution technique gives the solution only at one particular frequency.

Phasor Simulation of a Circuit Transient

You now apply the phasor solution method to a simple linear circuit. Open the example named Transient Analysis of a Linear Circuit (`power_transient`).

This circuit is a simplified model of a 60 Hz, 230 kV three-phase power system where only one phase is represented. The equivalent source is modeled by a voltage source (230 kV RMS / $\sqrt{3}$ or 132.8 kV RMS, 60 Hz) in series with its internal impedance ($R_s L_s$). The source feeds an RL load through a 150 km transmission line modeled by a single PI section (RL1 branch and two shunt capacitances, C1 and C2). A circuit breaker is used to switch the load (75 MW, 20 Mvar) at the receiving end of the transmission line. Two measurement blocks are used to monitor the load voltage and current.

The Powergui block at the lower-left corner indicates that the model is continuous.

Select the `I_load` and `V_line` signals. From the Simulation Data Inspector menu , select **Stream Selected Signals to Data Inspector**. Start the simulation and observe transients in voltage and current waveforms when the load is first switched off at $t = 0.0333$ s (2 cycles) and switched on again at $t = 0.1167$ s (7 cycles).

Invoking the Phasor Solution in the Powergui Block

You now simulate the same circuit using the phasor simulation method. This option is accessible through the Powergui block. Open the Powergui block and set **Simulation type** to **Phasor**. You must also specify the frequency used to solve the algebraic network equations. A default value of 60 Hz should already be entered in the **Phasor frequency** field. Close the Powergui and notice that the word **Phasors** now appears on the Powergui icon, indicating that the Powergui now applies this method to simulate your circuit. Before restarting the simulation, you need to specify the appropriate format for the two signals sent to the Scope block.

Selecting Phasor Signal Measurement Formats

If you now double-click the Voltage Measurement block or the Current Measurement block, you see that a menu allows you to output phasor signals in four different formats: **Complex** (default choice), **Real-Imag**, **Magnitude-Angle**, or just **Magnitude**. The **Complex** format is useful when you want to process complex signals. Note that the Scope block does not accept complex signals. Select **Magnitude** format for

both the Line Voltage and the Load Current Measurement blocks. This will allow you to observe the magnitude of the voltage and current phasors.

Restart the simulation. Open the Simulation Data Inspector. Waveforms obtained from the continuous simulation and the phasor simulation are superimposed in this plot.

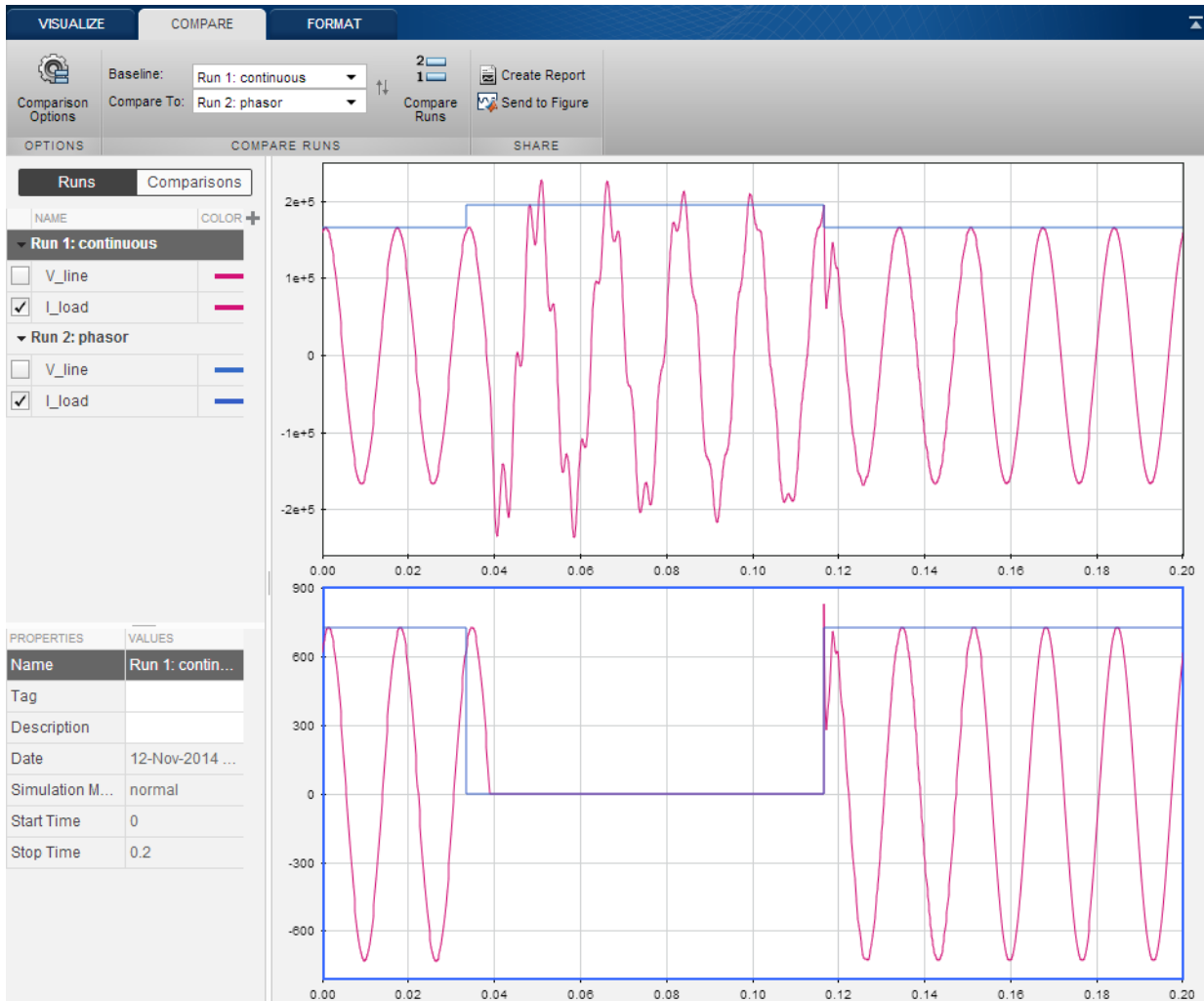

Waveforms Obtained with the Continuous and Phasor Simulation Methods

Note that with continuous simulation, the opening of the circuit breaker occurs at the next zero crossing of current following the opening order; whereas for the phasor simulation, this opening is instantaneous. This is because there is no concept of zero crossing in the phasor simulation.

Processing Voltage and Current Phasors

The **Complex** format allows the use of complex operations and processing of phasors without separating real and imaginary parts. Suppose, for example, that you need to compute the power consumption of the load (active power P and reactive power Q). The complex power S is obtained from the voltage and current phasors as

$$\bar{S} = P + jQ = \frac{1}{2} \cdot V \cdot I^*$$

where I^* is the conjugate of the current phasor. The $1/2$ factor is required to convert magnitudes of voltage and current from peak values to RMS values.

Select the **Complex** format for both current and voltage and, using blocks from the Simulink Math library, implement the power measurement as shown.

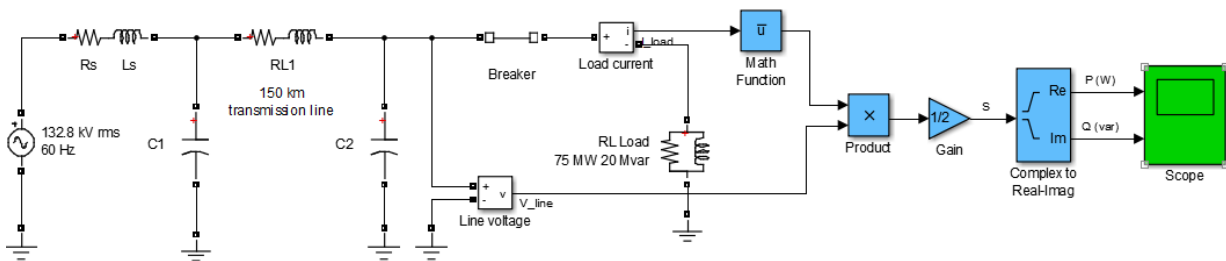

Power Computation Using Complex Voltage and Current

The **Complex to Magnitude-Angle** blocks are required to convert complex phasors to magnitudes before sending them to the scope.

Advanced Components and Techniques

This chapter introduces methods and devices that enhance your power system simulations and make them more realistic.

The first two tutorials illustrate power electronics, simple motors, and Fourier analysis. The third tutorial demonstrates three-phase power systems, electrical machinery, load flow, and use of the phasor solution method for transient stability studies of electromechanical systems. The fourth explains how you can create and customize your own nonlinear blocks.

- “Introducing Power Electronics” on page 2-2
- “Simulate Variable Speed Motor Control” on page 2-9
- “Three-Phase Systems and Machines” on page 2-22
- “Building and Customizing SimPowerSystems Models” on page 2-49
- “Building a Model Using Model Construction Commands” on page 2-59

Introducing Power Electronics

In this section...
“Introduction” on page 2-2
“Simulation of the TCR Branch” on page 2-3
“Simulation of the TSC Branch” on page 2-6

Introduction

In this section you

- Learn how to use power electronics components
- Learn how to use transformers
- Change initial conditions of a circuit

SimPowerSystems software is designed to simulate power electronic devices. This section uses a simple circuit based on thyristors as the main example.

Consider the circuit shown below. It represents one phase of a static var compensator (SVC) used on a 735 kV transmission network. On the secondary of the 735 kV/16 kV transformer, two variable susceptance branches are connected in parallel: one thyristor-controlled reactor (TCR) branch, in blue, and one thyristor-switched capacitor (TSC) branch, in red.

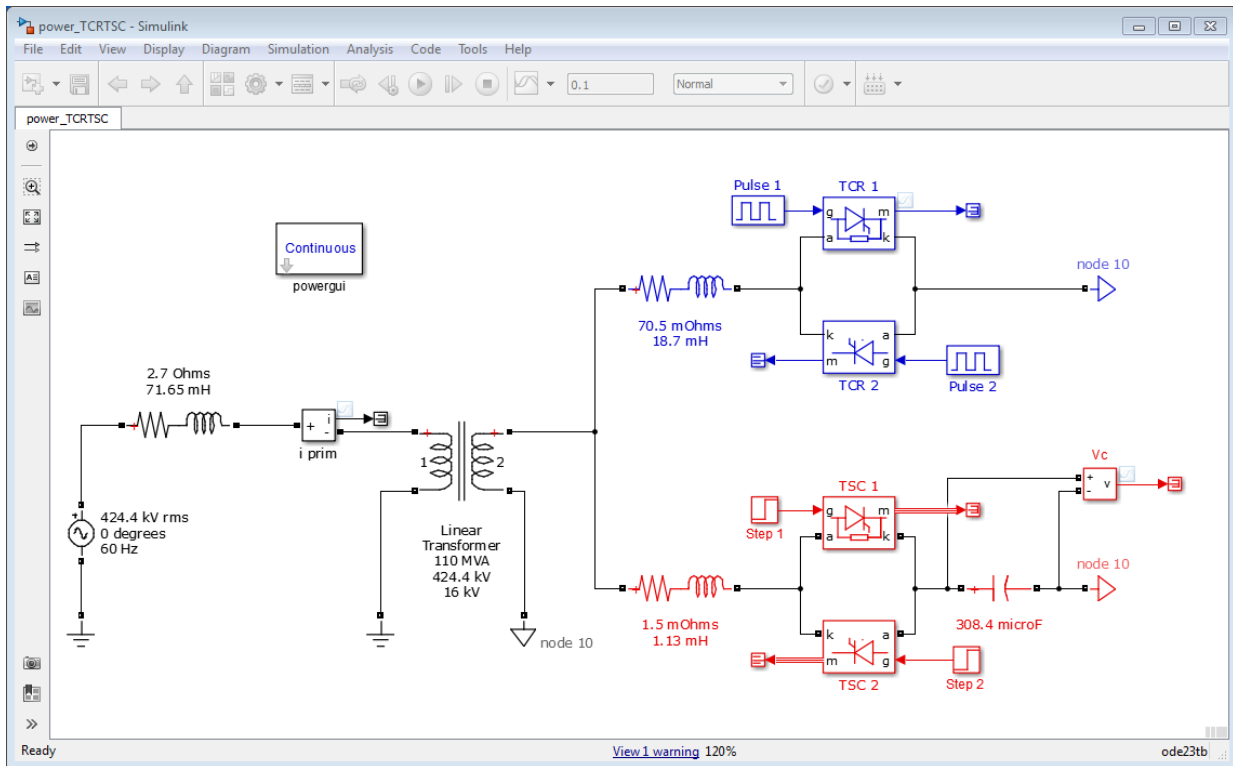

One Phase of a TCR/TSC Static Var Compensator

The TCR and TSC branches are both controlled by a valve consisting of two thyristor strings connected in antiparallel. An RC snubber circuit is connected across each valve. The TSC branch is switched on/off, thus providing discrete step variation of the SVC capacitive current. The TCR branch is phase controlled to obtain a continuous variation of the net SVC reactive current.

Simulation of the TCR Branch

- 1 Open a new window and save it as `power_TCR TSC`.
- 2 Open the Power Electronics library and copy the **Thyristor** block into the model.
- 3 Double-click the block to open the **Thyristor** dialog box and set the parameters as follows:

Ron	1e-3
Lon	0
Vf	14*0.8
Rs	500
Cs	0.15e-6

Notice that the snubber circuit is integral to the Thyristor dialog box.

- 4 Rename this block TCR 1 and duplicate it.
- 5 Connect this new thyristor TCR 2 in antiparallel with TCR 1, as shown in One Phase of a TCR/TSC Static Var Compensator.

As the snubber circuit has already been specified with TCR 1, the snubber of TCR 2 must be eliminated.

- 6 Open the TCR 2 dialog box and set the snubber parameters to

Rs	Inf
Cs	0

Notice that the snubber disappears on the block icon.

- 7 The Linear Transformer block is located in the Elements library. Copy it into the model, and open its dialog box. Set its nominal power, frequency, and winding parameters (**winding 1 = primary; winding 2 = secondary**) as shown in One Phase of a TCR/TSC Static Var Compensator.

The **Units** parameter allows you to specify the resistance R and leakage inductance L of each winding as well as the magnetizing branch Rm/Lm, either in SI units (ohms, henries) or in per units (pu). Keep the default pu setting to specify directly R and L in per unit quantities. As there is no tertiary winding, deselect **Three windings transformer**. Winding 3 disappears on the TrA block.

Finally, set the magnetizing branch parameters **Rm** and **Xm** at [500, 500]. These values correspond to 0.2% resistive and inductive currents. For more information on the per unit (pu) system, see “Per Unit System of Units”.

- 8 Add a voltage source, Ground block, and two Series RLC Branch blocks and set the parameters as shown in the **One Phase of a TCR/TSC Static Var Compensator** figure.

- 9 Add a current measurement to measure the primary current.
- 10 Notice that the Thyristor blocks have an output identified by the letter m. This output returns a Simulink vectorized signal containing the thyristor current (I_{ak}) and voltage (V_{ak}). These outputs are connected to terminators blocks. Select the signal line connected at the m output of the TCR 1 block and the signal connected at the i output of the i prim block. From the Simulation Data Inspector menu , select **Stream Selected Signals to Data Inspector**.
- 11 Copy two Simulink pulse generators into your system, name them Pulse1 and Pulse2, and connect them to the gates of the thyristor blocks.
- 12 Now you have to define the timing pulses of the two thyristors. At every cycle a pulse has to be sent to each thyristor α degrees after the zero crossing of the thyristor commutation voltage. Set the Pulse1 and Pulse2 block parameters as follows:

Amplitude	1
Period	1/60 s
Pulse width (% of period)	1% (3.6 degrees pulses)
Phase Delay	1/60+T for Pulse1 1/60+1/120+T for Pulse2

- 13 The pulses sent to TCR 2 are delayed by 180 degrees with respect to pulses sent to TCR 1. The delay T is used to specify the firing angle α . To get a 120 degree firing angle, specify T in the workspace by entering

$$T = 1/60/3;$$
- 14 Now open the **Simulation > Model Configuration Parameters** dialog box. Select the **ode23tb** integration algorithm. Keep the default parameters but set the relative tolerance to $1e-4$ and the stop time to 0.1.
- 15 Add a Powergui block at the top level of your model, then start the simulation. The results can be observed in the Simulation Data Inspector, as shown in the figure.

TCR Branch

Name	Color
TCR 1:1.Thyristor_current	Blue
TCR 1:1.Thyristor_voltage	Orange
i prim:1	Green

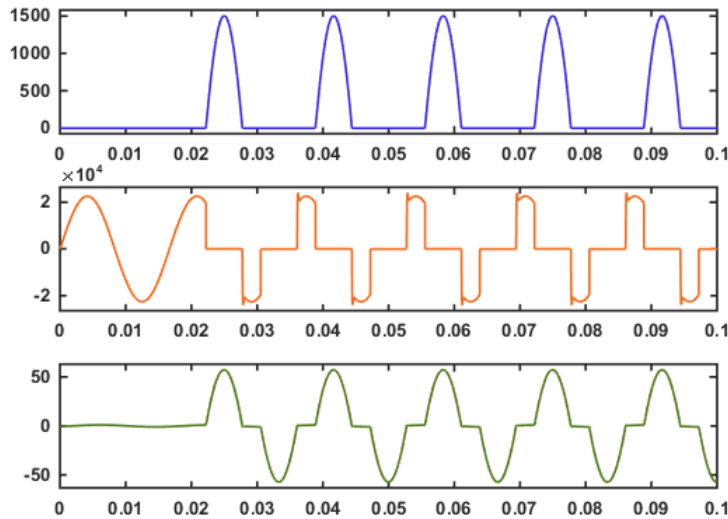

TCR Simulation Results

Simulation of the TSC Branch

You can now create the TSC branch.

- 1 Duplicate the TCR branch (shown in blue), rename the blocks, and specify resistance and inductance value as shown in the One Phase of a TCR/TSC Static Var Compensator figure.
- 2 Connect a capacitor of 308e-6 Farad in series with the TSC 1 and TSC 2 valve.
- 3 Connect a Voltage Measurement block across the capacitor. Connect the output of the block to a terminator block. Selected the signal and stream the selected signal to the Simulation Data Inspector.

- 4 Contrary to the TCR branch, which was fired by a synchronous pulse generator, a continuous firing signal is now applied to the two thyristors. Delete the two pulse generators. Copy a Step block from the Simulink library and connect its output at both gates of TSC 1 and TSC 2. Set its step time at 1/60/4 (energizing at the first positive peak of the source voltage).
- 5 Start the simulation.

As the capacitor is energized from zero, you can observe in the **Simulation Data Inspector** a low damping transient at 200 Hz, superimposed with the 60 Hz component in the capacitor voltage and primary current. During normal TSC operation, the capacitor has an initial voltage left since the last valve opening. To minimize the closing transient with a charged capacitor, the thyristors of the TSC branch must be fired when the source voltage is at maximum value and with the correct polarity. The initial capacitor voltage corresponds to the steady-state voltage obtained when the thyristor switch is closed. The capacitor voltage is 17.67 kVrms when the valve is conducting. At the closing time, the capacitor must be charged at the peak voltage.

$$U_c = 17670 \times \sqrt{2} = 24989 \text{ V}$$

- 6 Open the Powergui and select **Initial States Setting**. A list of all the state variables with their default initial values appears. The value of the initial voltage across the capacitor C (variable Uc_C) should be -0.3141 V. This voltage is not exactly zero because the snubber allows circulation of a small current when both thyristors are blocked. Now select the Uc_C state variable and enter **24989** in the upper right field. Then click the **Apply** button to make this change effective.
- 7 Start the simulation. As expected the transient component of capacitor voltage and current has disappeared. The voltages obtained with and without initial voltage are compared in the **Simulation Data Inspector** as shown in the figure.

Capacitor not charged

Name	Color
Vc:1	—

Precharged Capacitor

Name	Color
Vc:1	—

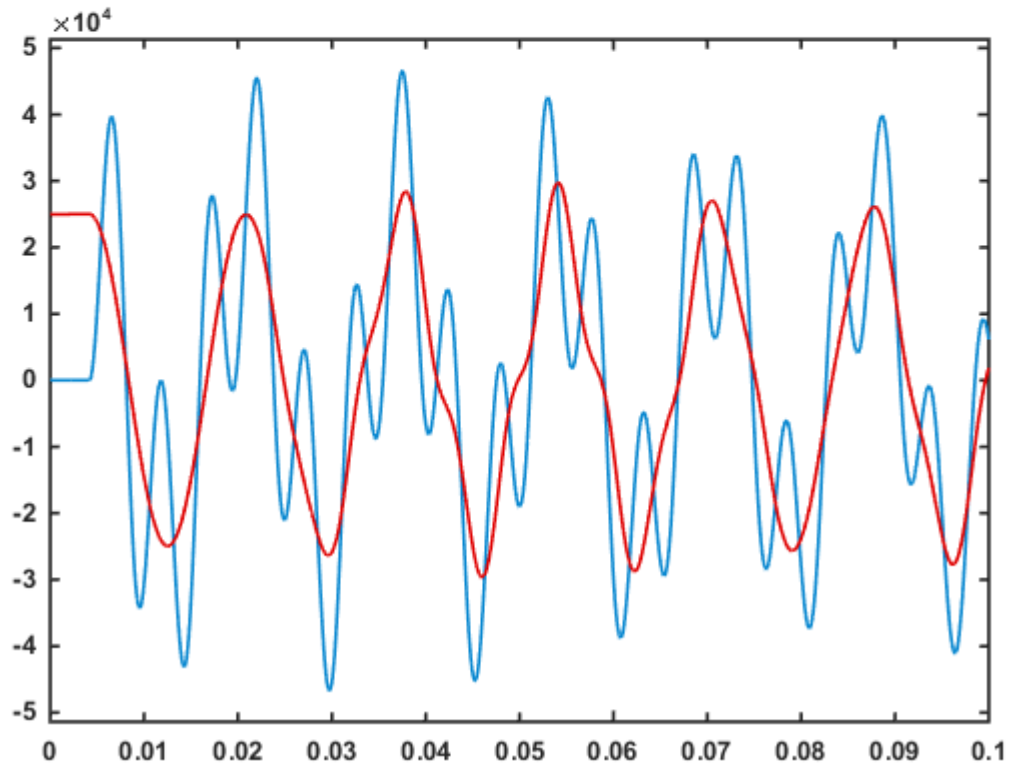

Transient Capacitor Voltage With and Without Initial Charge

Simulate Variable Speed Motor Control

In this section...

“Introduction” on page 2-9

“Building and Simulating the PWM Motor Drive” on page 2-10

“Using the Multimeter Block” on page 2-16

“Discretizing the PWM Motor Drive” on page 2-18

“Performing Harmonic Analysis Using the FFT Tool” on page 2-18

Introduction

In this section you

- Use electrical machines and power electronics to simulate a simple AC motor drive with variable speed control
- Learn how to use the **Universal Bridge** block
- Discretize your model and compare variable-step and fixed-step simulation methods
- Learn how to use the **Multimeter** block
- Learn how to use the **FFT** tool

Variable speed control of AC electrical machines makes use of forced-commutated electronic switches such as IGBTs, MOSFETs, and GTOs. Asynchronous machines fed by *pulse width modulation* (PWM) voltage sourced converters (VSC) are nowadays gradually replacing the DC motors and thyristor bridges. With PWM, combined with modern control techniques such as field-oriented control or direct torque control, you can obtain the same flexibility in speed and torque control as with DC machines. This section shows how to build a simple open loop AC drive controlling an asynchronous machine. Chapter 4 will introduce you to a specialized library containing models of DC and AC drives. These “ready to use” models will enable you to simulate electric drive systems without the need to build those complex systems yourself.

The Machines library contains four of the most commonly used three-phase machines: simplified and complete synchronous machines, asynchronous machine, and permanent magnet synchronous machine. Each machine can be used either in generator or motor mode. Combined with linear and nonlinear elements such as transformers, lines, loads, breakers, etc., they can be used to simulate electromechanical transients in an electrical network. They can also be combined with power electronic devices to simulate drives.

The Power Electronics library contains blocks allowing you to simulate diodes, thyristors, GTO thyristors, MOSFETs, and IGBT devices. You could interconnect several blocks together to build a three-phase bridge. For example, an IGBT inverter bridge would require six IGBTs and six antiparallel diodes.

To facilitate implementation of bridges, the **Universal Bridge** block automatically performs these interconnections for you.

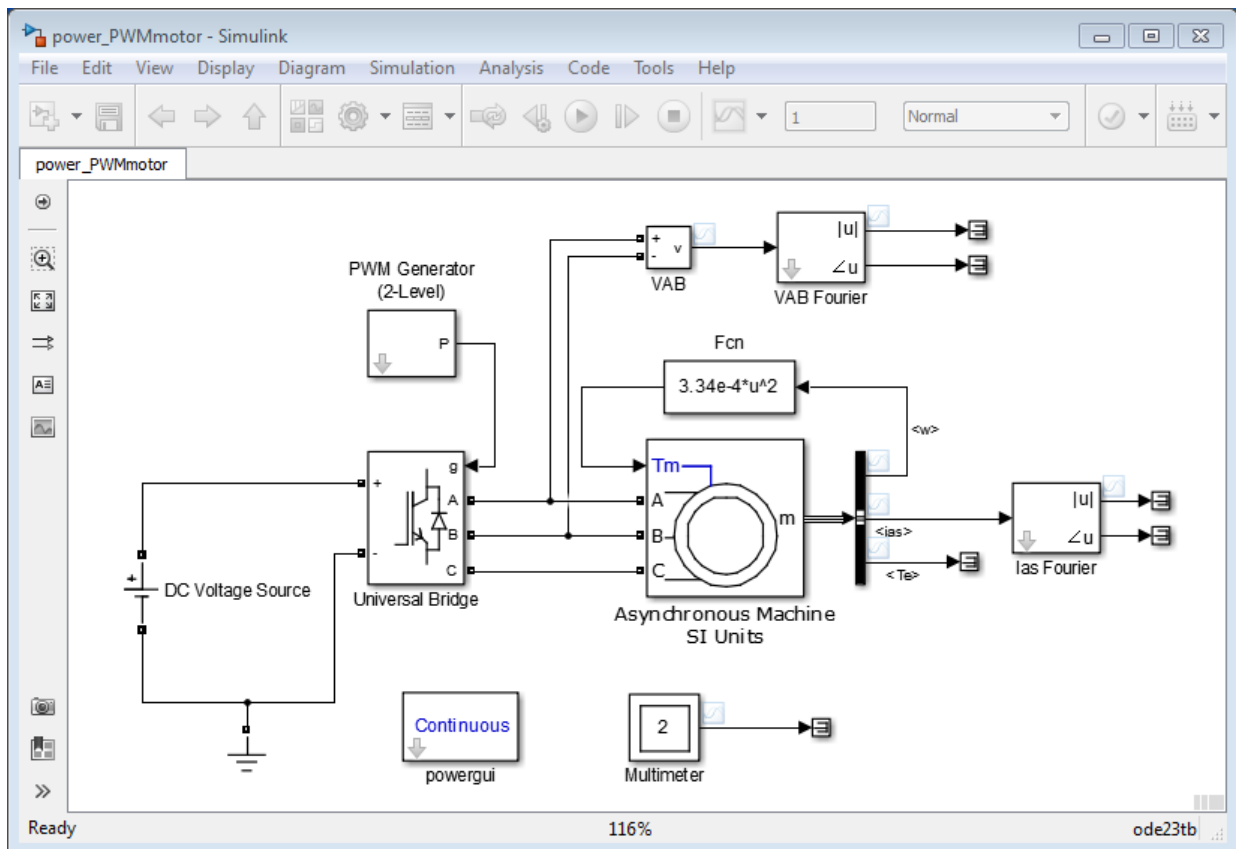

PWM Control of an Induction Motor

Building and Simulating the PWM Motor Drive

Follow these steps to build a PWM-controlled motor.

Assembling and Configuring the Model

- 1 Open a new window and save it as `power_PWMmotor`.
- 2 Open the Power Electronics library and copy the Universal Bridge block into your model.
- 3 Open the Universal Bridge dialog box and set its parameters as follows:

Power electronic device		IGBT/Diodes
Snubber		
	Rs	1e5 Ω
	Cs	inf
	Ron	1e-3 Ω
Forward voltages		
	Vf	0 V
	Vfd	0 V
Tail		
	Tf	1e-6 s
	Tt	1e-6 s

Notice that the snubber circuit is integral to the Universal Bridge dialog box. As the Cs capacitor value of the snubber is set to Inf (short-circuit), we are using a purely resistive snubber. Generally, IGBT bridges do not use snubbers; however, because each nonlinear element in SimPowerSystems software is modeled as a current source, you have to provide a parallel path across each IGBT to allow connection to an inductive circuit (stator of the asynchronous machine). The high resistance value of the snubber does not affect the circuit performance.

- 4 Open the Machines library. Copy the Asynchronous Machine SI Units block into your model.
- 5 Open the Asynchronous Machine dialog box and set its parameters as follows:

Nominal power, voltage (line-line), and frequency	[3*746, 220, 60]
Stator resistance and inductance	[1.115 0.005974]
Rotor resistance and inductance	[1.083 0.005974]

Mutual inductance

0.2037

Inertia constant, friction factor, and pole pairs [0.02 0.005752 2]

Setting the nominal power to 3*746 VA and the nominal line-to-line voltage V_n to 220 Vrms implements a 3 HP, 60 Hz machine with two pairs of poles. Its nominal speed is therefore slightly lower than the synchronous speed of 1800 rpm, or $\omega_s = 188.5$ rad/s.

- 6 Notice that the **Rotor type** parameter is set to **Squirrel cage**, and therefore the three rotor terminals a, b, and c are not accessible, because during normal motor operation these terminals should be short-circuited together.
- 7 Connect a Bus Selector block at the measurement output of the machine. When this block is connected to a machine measurement output, it allows you to access specific internal signals of the machine. Select the following signals: Stator measurements.Stator current is_a (A), Mechanical.Rotor speed (wm), and Mechanical.Electromagnetic troque T_e (N*m).

Loading and Driving the Motor

You now implement the torque-speed characteristic of the motor load. Assume a quadratic torque-speed characteristic (fan or pump type load). The torque T is then proportional to the square of the speed ω .

$$T = k \times \omega^2$$

The nominal torque of the motor is

$$T_n = \frac{3 \times 746}{188.5} = 11.87 \text{ Nm}$$

Therefore, the constant k should be

$$k = \frac{T_n}{\omega^2} = \frac{11.87}{188.5^2} = 3.34 \times 10^{-4}$$

- 1 Open the User-Defined Functions library of Simulink and copy the Fcn block into your model. Open the block menu and enter the expression of torque as a function of speed: $3.34e-4 * u^2$.

- 2 Connect the input of the Fcn block to the torque input of the motor, labeled Tm.
- 3 Open the Electrical Sources library and copy the DC Voltage Source block into your model. Open the block menu and set the voltage to 400 V.
- 4 Open the Measurements library and copy a Voltage Measurement block into your model. Change the block name to Vab.
- 5 Using a Ground block from the Elements library, complete the power elements and voltage sensor interconnections as shown in PWM Control of an Induction Motor.

Controlling the Inverter Bridge with a Pulse Generator

To control your inverter bridge, you need a pulse generator. Such a generator is available in the Control and Measurements/Measurements library:

- 1 Open the Control and Measurements/Pulse & Signal Generators blocks library and copy the PWM Generator (2-Level) block into your model. The converter operates in an open loop, and the three PWM modulating signals are generated internally. Connect the P output to the pulses input of the Universal Bridge block
- 2 Open the PWM Generator (2-Level) block dialog box and set the parameters as follows.

Generator type	Three-phase bridge (6 pulses)
Mode of operation	Unsynchronized
Carrier frequency	18*60Hz (1080 Hz)
Initial Phase	0 degrees
Minumum and maximum values	[-1,1]
Sampling technique	Natural
Internal generation of reference	selected
Modulation index	0.9
Reference signal frequency	60 Hz
Reference signal phase	0 degrees
Sample time	10e-6 s

- 3 The block has been discretized so that the pulses change at multiples of the specified time step. A time step of 10 μ s corresponds to +/- 0.54% of the switching period at 1080 Hz.

One common method of generating the PWM pulses uses comparison of the output voltage to synthesize (60 Hz in this case) with a triangular wave at the switching frequency (1080 Hz in this case). The line-to-line RMS output voltage is a function of the DC input voltage and of the modulation index m as given by the following equation:

$$V_{LLrms} = \frac{m}{2} \times \frac{\sqrt{3}}{\sqrt{2}} V_{dc} = m \times 0.612 \times V_{DC}$$

Therefore, a DC voltage of 400 V and a modulation factor of 0.90 yield the 220 Vrms output line-to-line voltage, which is the nominal voltage of the asynchronous motor.

Displaying Signals and Measuring Fundamental Voltage and Current

- 1 You now add blocks measuring the fundamental component (60 Hz) embedded in the chopped V_{ab} voltage and in the phase A current. Open the Control and Measurements library of the SimPowerSystems_ST library and copy the **Fourier** block into your model.

Open the Fourier block dialog box and check that the parameters are set as follows:

Fundamental frequency	60 Hz
Harmonic n	1
Initial input	[0 0]
Sample time	10e-6 s

Connect this block to the output of the V_{ab} voltage sensor.

- 2 Duplicate the Fourier block. To measure the phase A current, you connect this block to the **Stator current is_a** output of the Bus selector block.
- 3 Stream these signals to the Simulation Data Inspector: the T_e , i_{as} , and w signals of the measurement output of the Asynchronous Machine block, and the V_{AB} voltage.

Simulating the PWM Motor Drive with Continuous Integration Algorithm

Open the **Simulation > Configuration Parameters** dialog box. Select the **ode23tb** integration algorithm. Set the relative tolerance to $1e-4$, the absolute tolerance and the Max step size to **auto**, and the stop time to **1 s**. Open the **Simulation Data Inspector** and look at the signals.

The motor starts and reaches its steady-state speed of 181 rad/s (1728 rpm) after 0.5 s. At starting, the magnitude of the 60 Hz current reaches 90 A peak (64 A RMS) whereas its steady-state value is 10.5 A (7.4 A RMS). As expected, the magnitude of the 60 Hz voltage contained in the chopped wave stays at

$$220 \times \sqrt{2} = 311 \text{ V}$$

Also notice strong oscillations of the electromagnetic torque at starting. If you zoom in on the torque in steady state, you should observe a noisy signal with a mean value of 11.9 N.m, corresponding to the load torque at nominal speed.

If you zoom in on the three motor currents, you can see that all the harmonics (multiples of the 1080 Hz switching frequency) are filtered by the stator inductance, so that the 60 Hz component is dominant.

Motor starting at full voltage

Name	Color
<w>	Orange
<ias>	Yellow
<Te>	Purple
VAB:1	Red

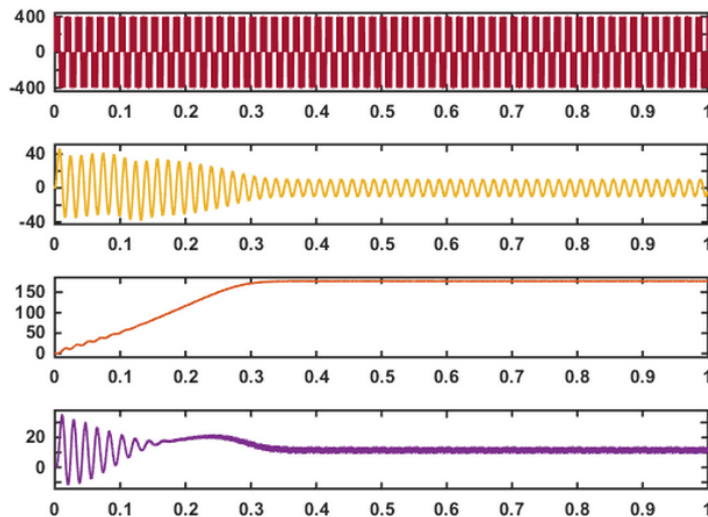

PWM Motor Drive; Simulation Results for Motor Starting at Full Voltage

Using the Multimeter Block

The Universal Bridge block is not a conventional subsystem where all the six individual switches are accessible. If you want to measure the switch voltages and currents, you must use the **Multimeter** block, which gives access to the bridge internal signals:

- 1 Open the **Universal Bridge** dialog box and set the **Measurement** parameter to **Device currents**.
- 2 Copy the Multimeter block from the Measurements library into your circuit. Double-click the Multimeter block. A window showing the six switch currents appears.
- 3 Select the two currents of the bridge arm connected to phase A. They are identified as

iSw1	Universal Bridge
iSw2	Universal Bridge

- 4 Click **Close**. The number of signals (2) is displayed in the Multimeter icon.
- 5 Send the signal from the Multimeter block to the Simulation Data Inspector.
- 6 Restart the simulation. The waveforms obtained for the first 20 ms are shown in this plot.

Currents in IGBT1 and IGBT2

Name	Color
Multimeter:1[1]	—
Multimeter:1[2]	—

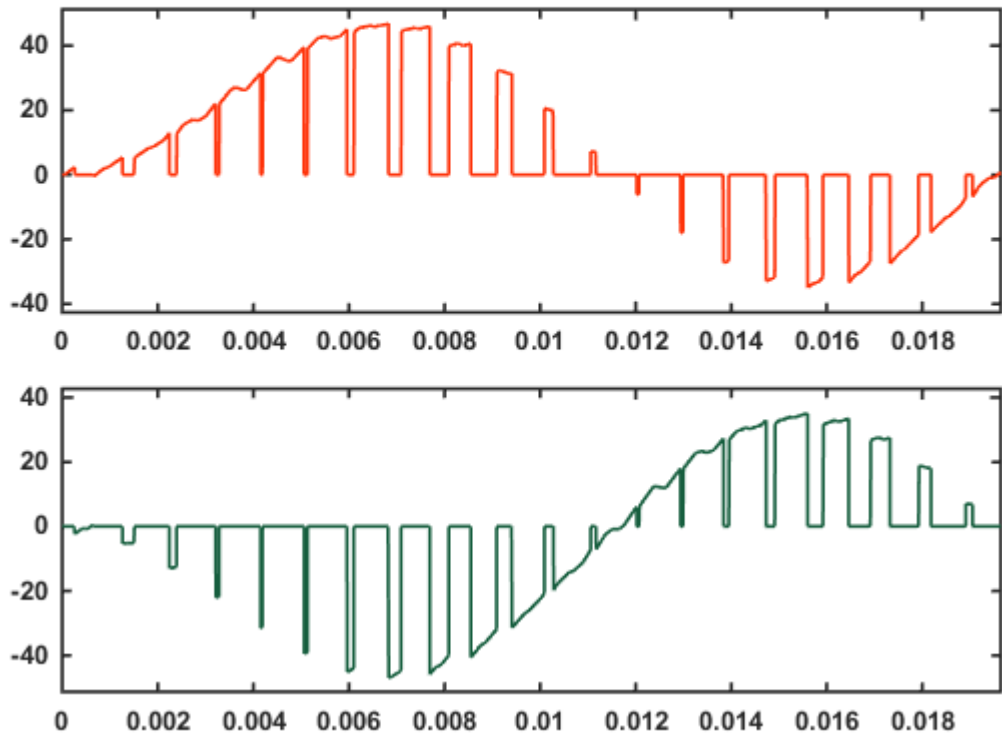

Currents in IGBT/Diode Switches 1 and 2

As expected, the currents in switches 1 and 2 are complementary. A positive current indicates a current flowing in the IGBT, whereas a negative current indicates a current in the antiparallel diode.

Note Multimeter block use is not limited to the Universal Bridge block. Many blocks of the Electrical Sources and Elements libraries have a Measurement parameter where you can select voltages, currents, or saturable transformer fluxes. A judicious use of the Multimeter block reduces the number of current and voltage sensors in your circuit, making it easier to follow.

Discretizing the PWM Motor Drive

You might have noticed that the simulation using a variable-step integration algorithm is relatively long. Depending on your computer, it might take tens of seconds to simulate one second. To shorten the simulation time, you can discretize your circuit and simulate at fixed simulation time steps.

Open the Powergui, click **Configure Parameters**, and in the Powergui block parameters dialog box set **Simulation type** to **Discrete**. Set the **Sample time** to $10e-6$ s. When you restart the simulation, the power system, including the asynchronous machine, is discretized at a 10 μ s sample time.

As there are no more continuous states in the electrical system, you do not need a variable-step integration method to solve this system. In the **Simulation > Configuration Parameters > Solver** dialog box pane, select the **Fixed-step** and **Discrete (no continuous states)** options.

Start the simulation. Observe that the simulation is now faster than with the continuous system. Results compare well with the continuous system.

Performing Harmonic Analysis Using the FFT Tool

The two Fourier blocks allow computation of the fundamental component of voltage and current while simulation is running. If you would like to observe harmonic components also you would need a Fourier block for each harmonic. This approach is not convenient.

Now use the FFT tool of Powergui to display the frequency spectrum of voltage and current waveforms. These signals are stored in your workspace in the ASM structure with time variable generated by the Scope block. Because your model is discretized, the signal saved in this structure is sampled at a fixed step and consequently satisfies the FFT tool requirements.

Open the Powergui and select **FFT Analysis**. A new window opens. Set the parameters specifying the analyzed signal, the time window, and the frequency range as follows:

Structure	ASM
Input	Vab
Signal number	1
Start time	0.7 s
Number of cycles	2
(pull-down menu)	Display FFT window
Fundamental frequency	60 Hz
Max Frequency	5000 Hz
Frequency axis	Harmonic order
Display style	Bar (relative to Fund or DC)

The analyzed signal is displayed in the upper window. Click **Display**. The frequency spectrum is displayed in the bottom window, as shown in the next figure.

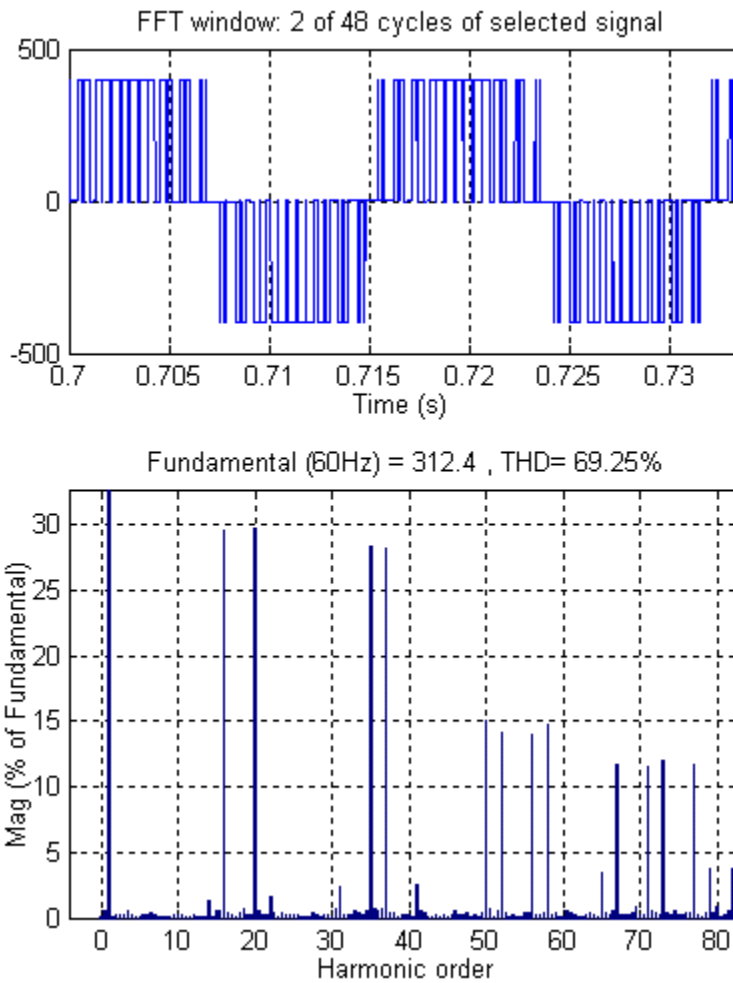

FFT Analysis of the Motor Line-to-Line Voltage

The fundamental component and *total harmonic distortion* (THD) of the V_{ab} voltage are displayed above the spectrum window. The magnitude of the fundamental of the inverter voltage (312 V) compares well with the theoretical value (311 V for $m=0.9$).

Harmonics are displayed in percent of the fundamental component. As expected, harmonics occur around multiples of carrier frequency ($n \cdot 18 \pm k$). Highest harmonics (30%) appear at 16th harmonic ($18 - 2$) and 20th harmonic ($18 + 2$).

Finally, select input I_a instead of V_{ab} and display its current spectrum.

Three-Phase Systems and Machines

In this section...
“Introduction” on page 2-22
“Three-Phase Network with Electrical Machines” on page 2-22
“Machine Initialization Tool” on page 2-25
“Load Flow Tool” on page 2-27
“Using the Phasor Solution Method for Stability Studies” on page 2-45

Introduction

In this section you

- Learn how to simulate a three-phase power system containing electrical machines and other three-phase models
- Perform a load flow study and initialize machines to start simulation in steady state by using the Machine Initialization and Load Flow tools (positive-sequence load flow and unbalanced load flow) of the powergui block.
- Simulate the power system and observe its dynamic performance by using and comparing results of the Continuous and Phasor SimPowerSystems simulation types.

You now use three types of machines of the Electrical Machines library: simplified synchronous machine, detailed synchronous machine, and asynchronous machine. You interconnect these machines with linear and nonlinear elements such as transformers, loads, and breakers to study the transient stability of an uninterruptible power supply using a diesel generator.

Three-Phase Network with Electrical Machines

The two-machine system shown in this single line diagram is this section's main example:

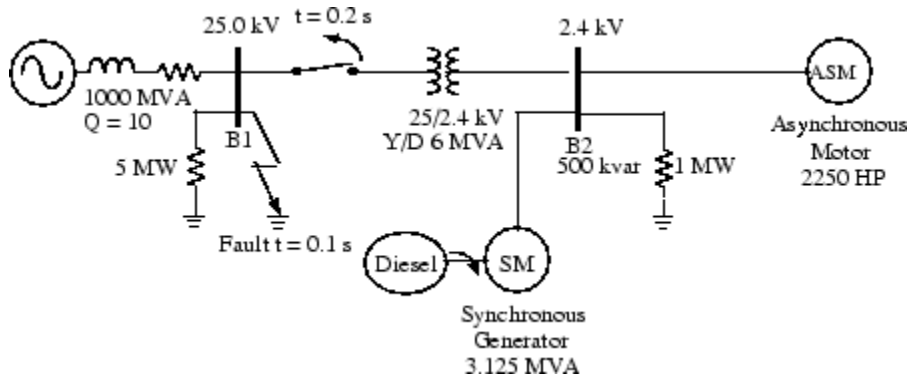

Diesel Generator and Asynchronous Motor on Distribution Network

This system consists of a plant (bus B2), simulated by a 1 MW resistive load and a motor load (ASM) fed at 2400 V from a distribution 25 kV system through a 6 MVA, 25/2.4 kV transformer, and from an emergency synchronous generator/diesel engine unit (SM).

The 25 kV system is modeled by a simple R-L equivalent source (short-circuit level 1000 MVA, quality factor $X/R = 10$) and a 5 MW load. The asynchronous motor is rated 2250 HP, 2.4 kV, and the synchronous machine is rated 3.125 MVA, 2.4 kV.

Initially, the motor develops a mechanical power of 2000 HP and the diesel generator is in standby, delivering no active power. The synchronous machine therefore operates as a synchronous condenser generating only the reactive power required to regulate the 2400 V bus B2 voltage at 1.0 pu. At $t = 0.1$ s, a three-phase to ground fault occurs on the 25 kV system, causing the opening of the 25 kV circuit breaker at $t = 0.2$ s, and a sudden increase of the generator loading. During the transient period following the fault and islanding of the motor-generator system, the synchronous machine excitation system and the diesel speed governor react to maintain the voltage and speed at a constant value.

This system is modeled in the `power_machines` example, shown in the following illustration.

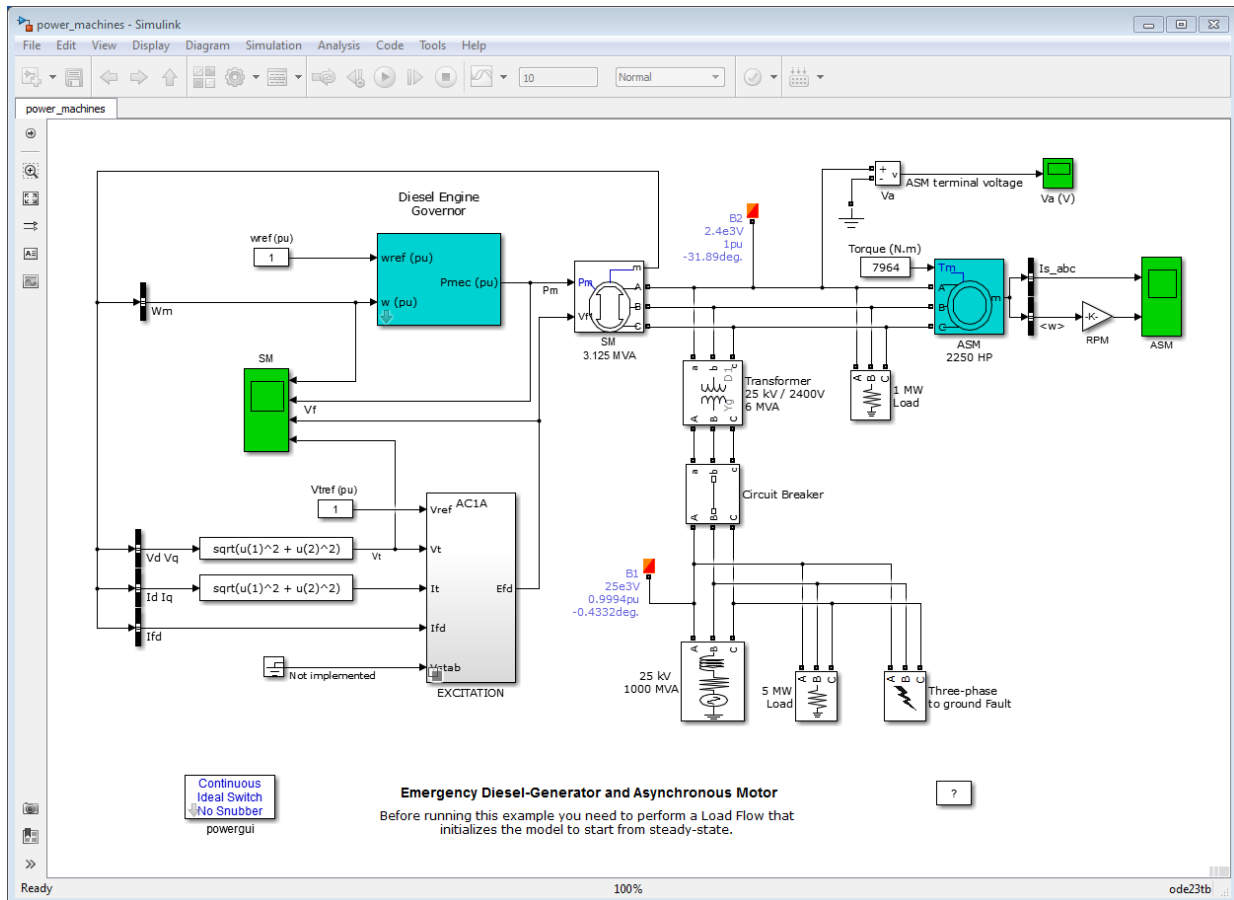

Power System of Diesel Generator and Asynchronous Motor on Distribution Network

The SM parameters as well as the diesel engine and governor models were taken from reference [1].

If you simulate this system for the first time, you normally do not know what the initial conditions are for the SM and ASM to start in steady state.

These initial conditions are

- SM block: Initial values of speed deviation (usually 0%), rotor angle, magnitudes and phases of currents in stator windings, and initial field voltage required to obtain the desired terminal voltage under the specified load flow
- ASM block: Initial values of slip, rotor angle, magnitudes and phases of currents in stator windings

Open the dialog box of the Synchronous Machine and Asynchronous Machine blocks. All initial conditions should be set at 0, except for the initial SM field voltage and ASM slip, which are set at 1 pu. Open the three scopes monitoring the SM and ASM signals as well as the bus B2 voltage. Start the simulation and observe the first 100 ms before fault is applied.

As the simulation starts, note that the three ASM currents start from zero and contain a slowly decaying DC component. The machine speeds take a much longer time to stabilize because of the inertia of the motor/load and diesel/generator systems. In our example, the ASM even starts to rotate in the wrong direction because the motor starting torque is lower than the applied load torque. Stop the simulation.

Machine Initialization Tool

To start the simulation in steady state with sinusoidal currents and constant speeds, all the machine states must be initialized properly. This is a difficult task to perform manually, even for a simple system. In the next section you learn how to use the **Machine Initialization** tool of the powergui block to initialize the machines.

- 1 In the **Tools** tab of the powergui block dialog box click the **Machine Initialization** button. A new window appears. The upper-right window displays a list of the machines appearing in your system.
- 2 Select SM 3.125 MVA in the machine list. The **Bus Type** parameter should already be initialized as **P & V generator**, indicating that the machine is controlling its active power and terminal voltage. For more info on the meaning of the **Bus type** parameter see “Load Flow Tool” on page 2-27.
- 3 Check that the desired **Terminal Voltage UAB** is initialized at the nominal machine voltage (2400 Vrms).
- 4 Set the **Active Power** to zero. The synchronous machine therefore absorbs or generates reactive power only to keep terminal voltage at 1 pu.
- 5 Select ASM 2250 HP in the machine list. The only parameter that needs to be set is the **Mechanical power** developed by the motor. Enter **1.492e6** (2000 HP = 2000*746 watts).

- Click the **Compute and Apply** button. The three phasors of line-to-line machine voltages, as well as currents, are updated as shown on the next figure. Values are displayed both in SI units (volts RMS or amperes RMS) and in pu.

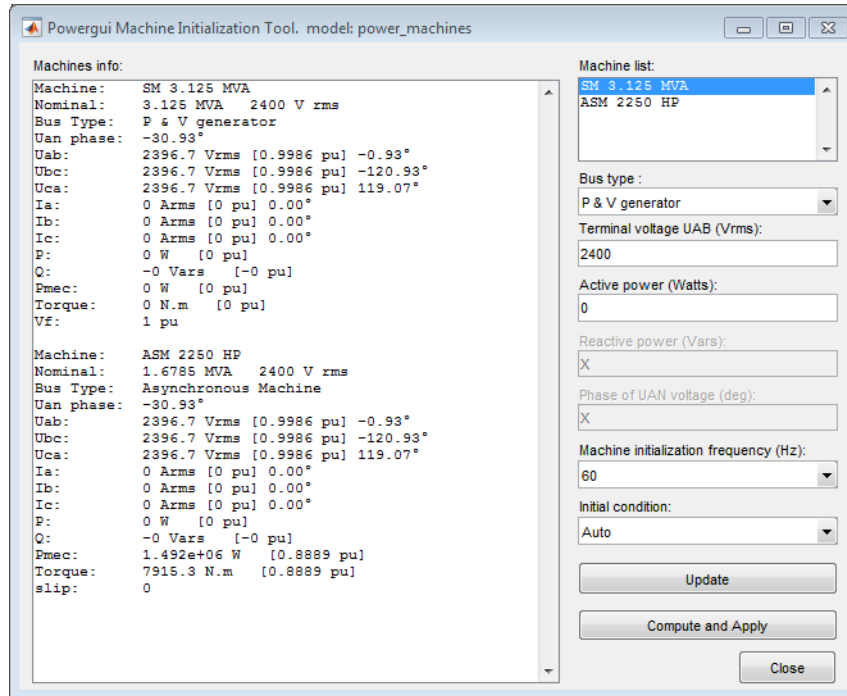

The **Machine info** section displays the SM active and reactive powers, mechanical power, and field voltage, the ASM active and reactive powers absorbed by the motor, slip, and torque.

- Close the **Machine Initialization** tool.
- Open the SM and ASM block dialogs and see that the initial conditions have been updated. Note that the ASM torque value (7964 N.m) has been entered in the Constant block connected at the ASM torque input.
- Double-click the Diesel Engine Governor block. The initial mechanical power is set to 0.0002701 pu.
- Open the Excitation block. Double-click the AC1A Excitation System block and select the **Initial Values** tab. The initial terminal voltage and field voltage are set to 1.0 pu and 1.427 pu, respectively.

- 11 The **Machine Initialization** tool also initializes the Constant blocks connected at the reference inputs (wref and vref) of the Governor and Excitation blocks, as well as the Constant block connected at the load torque input (T_m) of the Asynchronous Machine block.
- 12 Start the simulation. Open the three scopes displaying the internal signals of synchronous and asynchronous machines and phase A voltage. The simulation starts in steady state.

Note: To initialize machines, you can use the Load Flow tool instead of the Machine Initialization tool. The Load Flow tool allows you to display a more detailed load flow solution.

Load Flow Tool

The **Load Flow** tool of the powergui block uses the Newton-Raphson method and comes with a user interface that allows you to display load flow solution at all buses.

SimPowerSystems allows you to perform two types of load flows:

- Positive-sequence load flow applied to a three-phase system. Positive-sequence voltages as well as active power (P) and reactive power (Q) flows are computed at each three-phase bus.
- Unbalanced load flow applied to a mix of three-phase, two-phase, and single-phase systems. Individual phase voltage and PQ flow are computed for each phase.

For more information, see `power_loadflow`.

To solve a load flow, you need to determine these four quantities at each three-phase or single-phase bus:

- The net active power P and reactive power Q injected into the bus
- The voltage magnitude V and angle V_{angle} of bus positive-sequence voltage (positive-sequence voltage or phase voltage)

Bus Types

It is important that you understand the three bus types that are used by the Load Flow tool to solve a load flow. Before solving the load flow, two of the above quantities are

known at every bus and the other two are to be determined. Therefore, the following bus types are used:

- **PV bus**—For this type of bus, specify **P** and **V**. This is the generation bus where a generator such as a voltage source or three-phase synchronous machine is connected. Active power **P** is generated and generator terminal voltage **V** is imposed. The load flow solution returns the machine reactive power **Q**, required to maintain the reference voltage magnitude **V**, and the reference voltage angle **Vangle**.
- **PQ bus**—At this bus, specified active power **P** and reactive power **Q** are either injected into the bus (generation PQ bus) or absorbed by a load connected at that bus. The load flow solution returns bus voltage magnitude **V** and angle **Vangle**.
- **Swing bus**—This bus imposes voltage magnitude **V** and angle **Vangle**. The load flow solution returns the active power **P** and reactive power **Q**, generated or absorbed at that bus in order to balance generated power, loads, and losses. At least one bus in the model must be defined as a swing bus, but usually a single swing bus is required unless you have isolated networks. Normally for a positive-sequence load flow, you select one synchronous machine or voltage source as a swing bus. For an unbalanced load flow, you can select the three phases of a Three-Phase Voltage Source block or single-phase AC Voltage Source blocks as swing buses.

Performing Load Flow Analysis and Initializing Your Model

To perform a load flow analysis and initialize your model so that it starts in steady state:

- 1 Define the model buses using Load Flow Bus blocks.
- 2 Specify the load flow parameters of all blocks having load flow parameters. These blocks are referred to as load flow blocks.
- 3 Solve the load flow and, eventually, interactively modify the load flow parameters until a satisfactory solution is obtained.
- 4 Save the load flow parameters and machine initial conditions in the model.

The load flow blocks and the Load Flow Bus block are described in the next sections.

Load Flow Blocks for Positive-Sequence Load Flow

Load flow blocks are SimPowerSystems blocks in which you can specify active power (**P**) and reactive power (**Q**) to solve the positive-sequence load flow. They are:

- Asynchronous Machine

- Simplified Synchronous Machine
- Synchronous Machine
- Three-Phase Dynamic Load
- Three-Phase Parallel RLC Load
- Three-Phase Series RLC Load
- Three-Phase Programmable Voltage Source
- Three-Phase Source

You specify P and Q in the **Load Flow** tab of the block dialog boxes.

Load Flow Parameters of Three-Phase Sources and Synchronous Machines

The Three-Phase Sources and Synchronous Machine blocks allow control of their generated or absorbed powers P and Q and their positive-sequence terminal voltage. You can specify the generator bus type as swing, PV, or PQ.

Load Flow Parameters of Asynchronous Machine Blocks

The Asynchronous Machine block requires specification of the mechanical power P_{mec} at the machine shaft.

Load Flow Parameters of the RLC Load Blocks

You can specify the Three Phase RLC Load blocks as constant impedance (Z), constant PQ power, or constant current (I).

Load Flow Parameters of Dynamic Load Blocks

The Three-Phase Dynamic Load block dialog box does not have a **Load Flow** tab. The load is always considered as a constant PQ load. P and Q are the initial active and reactive power P_0 , Q_0 that you specify by using the **Active and reactive power at initial voltage** parameter. The **Initial positive-sequence voltage V_0** parameter (Mag and Phase) updates according to the load flow solution.

Load Flow Blocks for Unbalanced Load Flow

Load flow blocks are SimPowerSystems blocks in which you can specify active power (P) and reactive power (Q) to solve the load flow at each phase of every bus. They are:

- AC Voltage Source

- Asynchronous Machine
- Parallel RLC Load
- Series RLC Load
- Synchronous Machine
- Three-Phase Dynamic Load
- Three-Phase Parallel RLC Load
- Three-Phase Series RLC Load
- Three-Phase Source

You specify P and Q in the **Load Flow** tab of the block dialog boxes.

Load Flow Parameters of Single-Phase and Three-Phase Sources

The single-phase AC Voltage Source block allows control of its generated or absorbed powers P and Q and its terminal voltage. The Three-Phase Source block allows control of generated or absorbed powers P and Q and terminal voltages for each phase (phase A, B, and C). For these two blocks, you can specify the generator type as swing, PV, or PQ.

Load Flow Parameters of Synchronous Machine

The Three-Phase Synchronous Machine block allows control of its generated or absorbed powers P and Q (total of phases A, B, and C) and its positive-sequence terminal voltage. You can specify the generator type as PV or PQ.

Load Flow Parameters of Asynchronous Machine Blocks

The Asynchronous Machine block requires specification of the mechanical power P_{mec} developed in positive-sequence at the machine shaft.

Load Flow Parameters of the RLC Load Blocks

You can specify the single-phase and three-phase RLC Load blocks as constant impedance (Z), constant PQ power, or constant current (I). You can connect single-phase loads phase-to-ground or phase-to-phase. You can connect three-phase loads connected in Wye (grounded or floating) or delta.

Load Flow Parameters of Dynamic Load Blocks

The Three-Phase Dynamic Load block dialog box does not have a **Load Flow** tab. The load is always considered as a constant PQ load. P and Q are the initial active and

reactive power P_0 , Q_0 that you specify by using the **Active and reactive power at initial voltage** parameter. The **Initial positive-sequence voltage V_0** parameter (Mag and Phase) updates according to the load flow solution.

Load Flow Bus Blocks

Use the Load Flow Bus block to define the buses in your model.

If you perform a positive-sequence load flow, you connect a Load Flow Bus block with the **Connectors** parameter specified as **single** to any phase (A, B, or C) of every load flow block in the model. When several load flow blocks are connected together at the same nodes, only one Load Flow Bus block is required to identify the bus.

If you perform an unbalanced load flow, you connect a Load Flow Bus block to all phases of every load flow block in the model. Depending on the number of phases, you need to specify the appropriate **Connectors** parameter by selecting either three connectors (ABC), two connectors (AB, AC, or BC) or a single connector (A, B, or C). When several load flow blocks are connected together at the same nodes, only one Load Flow Bus block is required to identify the bus. In the load flow report, each bus is identified by its **Bus identification** parameter followed by `_a`, `_b`, or `_c`.

These examples show the use of load flow blocks and Load Flow Bus blocks:

- `power_LFnetwork_5bus` shows a positive-sequence load flow on a five-bus system.
- `power_13nodeTestFeeder` shows an unbalanced load flow on a 13-bus system (mix of three-phase, two-phase, and single-phase buses).

Example of Positive-Sequence Load Flow

In the Command window, type `power_LFnetwork_5bus` to access a model containing five Load Flow Bus blocks and six load flow blocks.

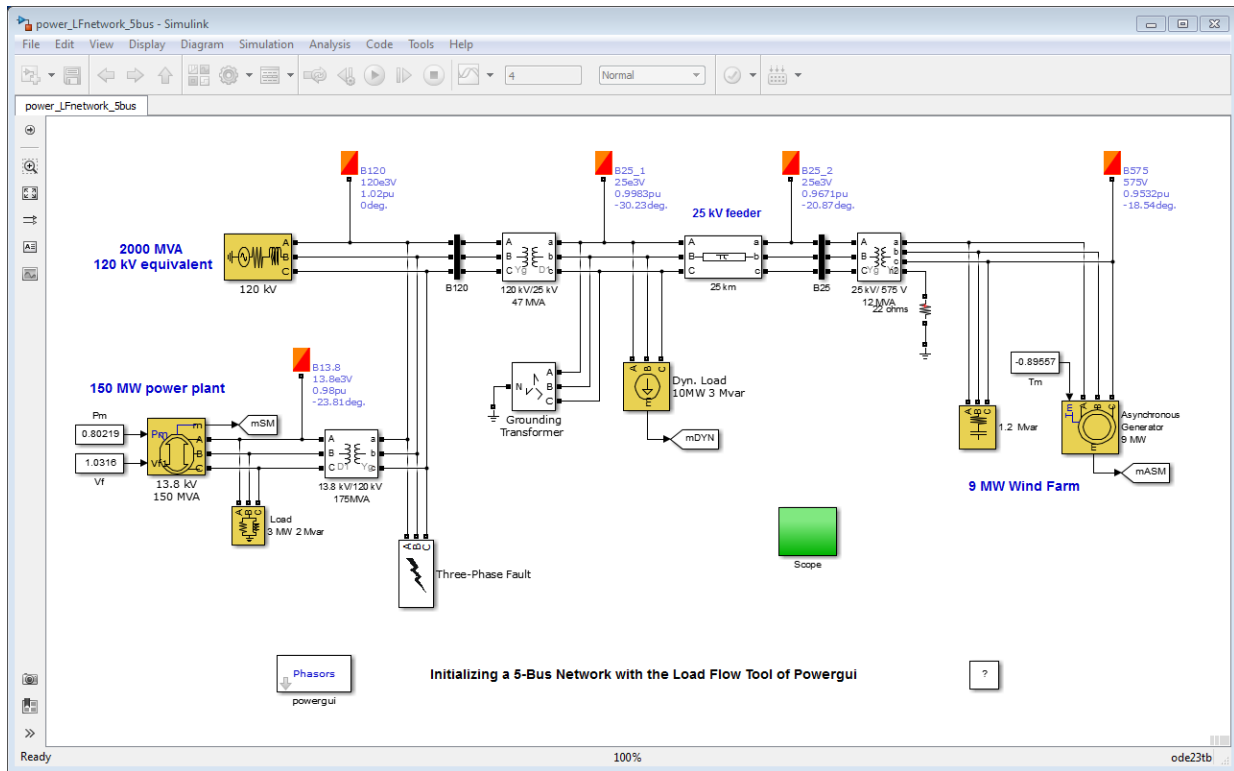

The Load Flow Bus blocks are shown in orange and the load flow blocks are shown in yellow.

The Load Flow Bus blocks specify the bus base voltages (nominal phase-to-phase rms voltage). They also specify the voltage at PV buses or the voltage and angle of the swing buses. Once the load flow is solved, the Load Flow Bus block displays the bus positive-sequence voltage magnitude and phase angle as block annotations.

The bus type (PV, PQ, or swing) is determined by the load flow blocks connected to the bus. If you have several load flow blocks with different types (specified in the **Generator type** parameter or in the **Load type** parameter) connected to the same bus, the Load Flow tool determines the resulting bus type (swing, PQ, or PV).

In the power_LFnetwork_5bus example, the bus types are determined as follows:

Bus	Load Flow Blocks	Resulting Bus Type
B120	120 kV Three-Phase Source - Generator type = swing	swing V=1.02 p.u. 0 deg. (Specify voltage and angle in the B120 Load Flow Bus block.)
B13.8	13.8 kV 150 MVA Synchronous Machine - Generator type = PV 3 MW 2 Mvar RLC Load - Load type = constant PQ	PV P = 117 MW V = 0.98 pu (Specify voltage in the B13.8 Load Flow Bus block.)
B25_1	10 MW, 3 Mvar Dynamic Load - Implicit load type = constant PQ	PQ P = -10 MW Q = -3 Mvar
B25_2	No load flow block	PQ P = 0 MW Q = 0 Mvar
B575	Asynchronous generator 9 MW 1.2 Mvar RLC Load - Load type = constant Z	PQ P = 0 MW Q = 0 Mvar (Constant Z load is included in the Ybus admittance matrix.)

Some restrictions apply when you connect several source blocks and synchronous machines at the same bus:

- Two swing generators cannot be connected in parallel.
- A swing generator cannot be connected in parallel with a PV ideal voltage source.
- When a swing voltage source with RL impedance is connected to a PV generator, the swing bus is automatically moved to the ideal voltage source connection node, behind the RL source impedance.
- Only one PV generator with finite Q limits can be connected at a generation bus. However, you may have other PQ generators and loads connected on the same bus.

For more information on how to use the Load Flow Bus block in your model, see the Load Flow Bus block reference page.

Open the Load Flow Tool to Perform Load Flow Analysis

Once you have entered the load flow parameters in the Load Flow Bus blocks and in the various load flow blocks, open the load flow tool by clicking the **Load Flow** button of the powergui block. The tool displays a summary of the load flow data of the model. The table below shows the data found in the power_LFnetwork_5bus model.

The screenshot shows the 'Powergui Load Flow Tool' window for the model 'power_LFnetwork_5bus'. The window contains a table with 15 columns and 7 rows of data. The columns are: Block type, Bus type, Bus ID, Vbase (kV), Vref (pu), Vangle (deg), P (MW), Q (Mv...), Qmin (Mvar), Qmax (Mvar), V_LF (pu), Vangle_LF (deg), P_LF (MW), Q_LF (Mvar), and Block Name. The rows represent different load flow blocks and buses in the model.

	Block type	Bus type	Bus ID	Vbase (kV)	Vref (pu)	Vangle (deg)	P (MW)	Q (Mv...	Qmin (Mvar)	Qmax (Mvar)	V_LF (pu)	Vangle_LF (deg)	P_LF (MW)	Q_LF (Mvar)	Block Name
1	Vsrc	swing	B120	120.00	1.0200	0.00	10.00	3.00	-Inf	Inf	0	0.00	0.00	0.00	120 kV
2	SM	PV	B13.8	13.80	0.9900	0.00	120.00	0.00	-Inf	Inf	0	0.00	0.00	0.00	13.8 kV 150 MVA
3	RLC load PQ		B13.8	13.80	0.9900	0.00	3.00	2.00	-Inf	Inf	0	0.00	0.00	0.00	Load 3 MW 2 Mvar
4	DYN load PQ		B25_1	25.00	1	0.00	10.00	3.00	-Inf	Inf	0	0.00	0.00	0.00	Dyn. Load 10MW 3 Mvar
5	Bus	-	B25_2	25.00	1	0.00	0.00	0.00	0.00	0.00	0	0.00	0.00	0.00	Load Flow Bus3
6	ASM	-	B575	0.58	1	0.00	-9.00	0.00	0.00	0.00	0	0.00	0.00	0.00	Asynchronous Generat
7	RLC load Z		B575	0.58	1	0.00	0.02	-1.20	-Inf	Inf	0	0.00	0.00	0.00	1.2 Mvar

Note that the table contains seven lines, whereas there are only six load flow blocks in the model. This is because the bus B25_2 is not connected to any load flow block. Line 5 is added in the table for that particular bus, so that you can see all buses listed together with their bus voltages. This bus will be considered in the load flow analysis as a PQ bus with zero P and Q.

The first column identifies the block type. The second column displays the bus type of the load flow blocks. The following four columns give the bus identification label, the bus base voltage, the reference voltage (in pu of base voltage) and the voltage angle of the load flow bus where the block is connected. The following columns are the P and Q values specified in the **Load Flow** tab of the blocks.

The last five columns display the current load flow solution, as well as the full block name of the load flow block. For now, the load flow has not yet been performed and the columns display zero values.

V_LF (pu)	Vangle_LF (deg)	P_LF (MW)	Q_LF (Mvar)	Block Name
0	0.00	0.00	0.00	120 kV
0	0.00	0.00	0.00	13.8 kV 150 MVA
0	0.00	0.00	0.00	Load 3 MW 2 Mvar
0	0.00	0.00	0.00	Dyn. Load 10MW 3 Mvar
0	0.00	0.00	0.00	Load Flow Bus3
0	0.00	0.00	0.00	Asynchronous Generator
0	0.00	0.00	0.00	1.2 Mvar

The load flow parameters in the **Preferences** tab of the Powergui are used to build the Ybus network admittance matrix and to solve the load flow. The base power is used to specify units of the normalized Ybus matrix in pu/Pbase and bus base voltages. The power_LFnetwork_5bus model contains five buses; consequently, the Ybus matrix will be a 5x5 complex matrix evaluated at the frequency specified by the **Frequency (Hz)** parameter.

The load flow algorithm uses an iterative solution based on the Newton-Raphson method. The **Max iterations** parameter defines the maximum number of iterations. The load flow algorithm will iterate until the P and Q mismatch at each bus is lower than the **PQ tolerance** parameter (in pu/Pbase). The power mismatch is defined as the difference between the net power injected into the bus by generators and PQ loads and the power transmitted on all links leaving that bus.

To avoid a badly conditioned Ybus matrix, you should select the **Base power** parameter value in the range of nominal powers and loads connected to the network. For a transmission network with voltages ranging from 120 kV to 765 kV, a 100 MVA base is usually selected. For a distribution network or for a small plant consisting of generators, motors, and loads having a nominal power in the range of hundreds of kilowatts, a 1 MVA power base is better adapted.

To solve the load flow, click the **Compute** button. The load flow solution is then displayed in the last five columns of the table.

V_LF (pu)	Vangle_LF (deg)	P_LF (MW)	Q_LF (Mvar)	Block Name
1.0200	0.00	-114.37	62.75	120 kV
0.9800	-23.81	120.00	-37.25	13.8 kV 150 MVA
0.9800	-23.81	3.00	2.00	Load 3 MW 2 Mvar
0.9983	-30.23	10.00	3.00	Dyn. Load 10MW 3 Mvar
0.9671	-20.87	0.00	0.00	Load Flow Bus3
0.9532	-18.54	-8.90	4.38	Asynchronous Generator 9 MW
0.9532	-18.54	0.02	-1.09	1.2 Mvar

To display the load flow report showing power flowing at each bus, click the **Report** button. You can also save this report in a file by specifying the file name at the prompt.

The report starts with displaying the summary of active and reactive powers, showing total PQ sharing between generators (SM and Vsrc type blocks), PQ loads (PQ type RLC loads and DYN loads), shunt constant Z loads (Z type RLC loads and magnetizing branches of transformers) and asynchronous machine loads (ASM):

The Load Flow converged in 2 iterations !

SUMMARY for subnetwork No 1

```

Total generation :    P=  5.61 MW   Q= 25.51 Mvar
Total PQ load :      P= 13.00 MW   Q=  5.00 Mvar
Total Zshunt load :  P=  0.68 MW   Q= -0.51 Mvar
Total ASM load :     P= -8.90 MW   Q=  4.38 Mvar
Total losses :       P=  0.83 MW   Q= 16.64 Mvar
    
```

The **Total losses** line represents the difference between generation and loads (PQ type + Z type +ASM). It therefore represents series losses. After this summary, a voltage and power report is presented for each bus:

```

1 : B120  V= 1.020 pu/120kV 0.00 deg ; Swing bus
      Generation : P= -114.39 MW Q=  62.76 Mvar
      PQ_load    : P=   0.00 MW Q=   0.00 Mvar
      Z_shunt    : P=   0.25 MW Q=   0.23 Mvar
--> B13.8      : P= -116.47 MW Q=  53.89 Mvar
--> B25_1      : P=   1.84 MW Q=   8.63 Mvar

2 : B13.8  V= 0.980 pu/13.8kV -23.81 deg
      Generation : P= 120.00 MW Q= -37.25 Mvar
      PQ_load    : P=   3.00 MW Q=   2.00 Mvar
      Z_shunt    : P=   0.17 MW Q=   0.17 Mvar
--> B120       : P= 116.83 MW Q= -39.42 Mvar
    
```

```

3 : B25_1 V= 0.998 pu/25kV -30.22 deg
      Generation : P=  0.00 MW Q=  0.00 Mvar
      PQ_load    : P=  10.00 MW Q=  3.00 Mvar
      Z_shunt    : P=  0.25 MW Q=  0.21 Mvar
--> B120       : P=  -1.83 MW Q= -8.44 Mvar
--> B25_2      : P=  -8.41 MW Q=  5.23 Mvar

4 : B25_2 V= 0.967 pu/25kV -20.85 deg
      Generation : P=  0.00 MW Q=  0.00 Mvar
      PQ_load    : P=  -0.00 MW Q= -0.00 Mvar
      Z_shunt    : P=  0.01 MW Q= -0.03 Mvar
--> B25_1      : P=  8.87 MW Q= -3.67 Mvar
--> B575       : P= -8.88 MW Q=  3.70 Mvar

5 : B575 V= 0.953 pu/0.575kV -18.51 deg
      Generation : P=  0.00 MW Q=  0.00 Mvar
      PQ_load    : P=  -0.00 MW Q= -0.00 Mvar
      Z_shunt    : P=  0.01 MW Q= -1.09 Mvar
--> ASM        : P= -8.90 MW Q=  4.38 Mvar
--> B25_2      : P=  8.89 MW Q= -3.29 Mvar

```

For every bus, the bus voltage and angle are listed on the first line. The next 3 lines give the PQ generated at the bus (all SM and voltage sources), the PQ absorbed by the PQ type loads, and the PQ absorbed by the Z type loads.

The last lines, preceded by an arrow (->), list the PQ transmitted to neighbor buses connected through lines, series impedances, and transformers, as well power absorbed by ASM.

Apply the Load Flow Solution to Your Model

When performing a load flow analysis, you may need to iterate on P, Q, V values until you find satisfactory voltages at all buses. This may require, for example, changing generated power, load powers, or reactive shunt compensation.

To change the load flow setup, you need to edit the parameters of the load flow blocks and of the Load Flow Bus blocks. Then click the **Update** button to refresh the load flow data displayed by the table. The previous load flow solution is then deleted from the table. Click the **Compute** button to obtain a new load flow solution corresponding to the changes you made.

Once you have obtained a satisfactory load flow, you need to update the model initial conditions according to the load flow solution. Click the **Apply to Model** button to

initialize the machine blocks of the model, as well as the initial conditions of regulators connected to the machines.

Open the Three-Phase Parallel RLC Load block connected at the B13.8 bus. As the **Load type** specified in the **Load Flow** tab is constant PQ, the nominal voltage of this block has been changed to the corresponding bus voltage of 0.98 pu. The **Nominal phase-phase voltage** parameter is set to $(13800) * 0.98$.

Open the Three-Phase Dynamic Load block connected at the B25_1bus. The **Initial positive-sequence voltage V_0** is set to $[0.998241 \text{ pu } -30.2228 \text{ deg}]$.

Note that the voltage magnitudes and angles obtained at each bus have been written as block annotations under the Load Flow Bus blocks.

Open the scope and start the simulation.

The Three-Phase Fault block has been programmed to apply a six-cycle fault at B120 bus.

Observe waveforms of SM active power, SM and ASM speeds, and PQ of DYN load, and notice that simulation starts in steady state.

Example of Unbalanced Load Flow

At the command prompt, enter `power_13NodeTestFeeder` to open a model containing 12 Load Flow Bus blocks and 13 load flow blocks. This model is a benchmark network taken from the “Radial Distribution Test Feeder” Distribution System Analysis Subcommittee Report, Power Engineering Society, pages 908–912, 2001.

The original benchmark system contains 13 nodes. However, as the `power_13NodeTestFeeder` model does not include the regulating transformer, it contains only 12 nodes.

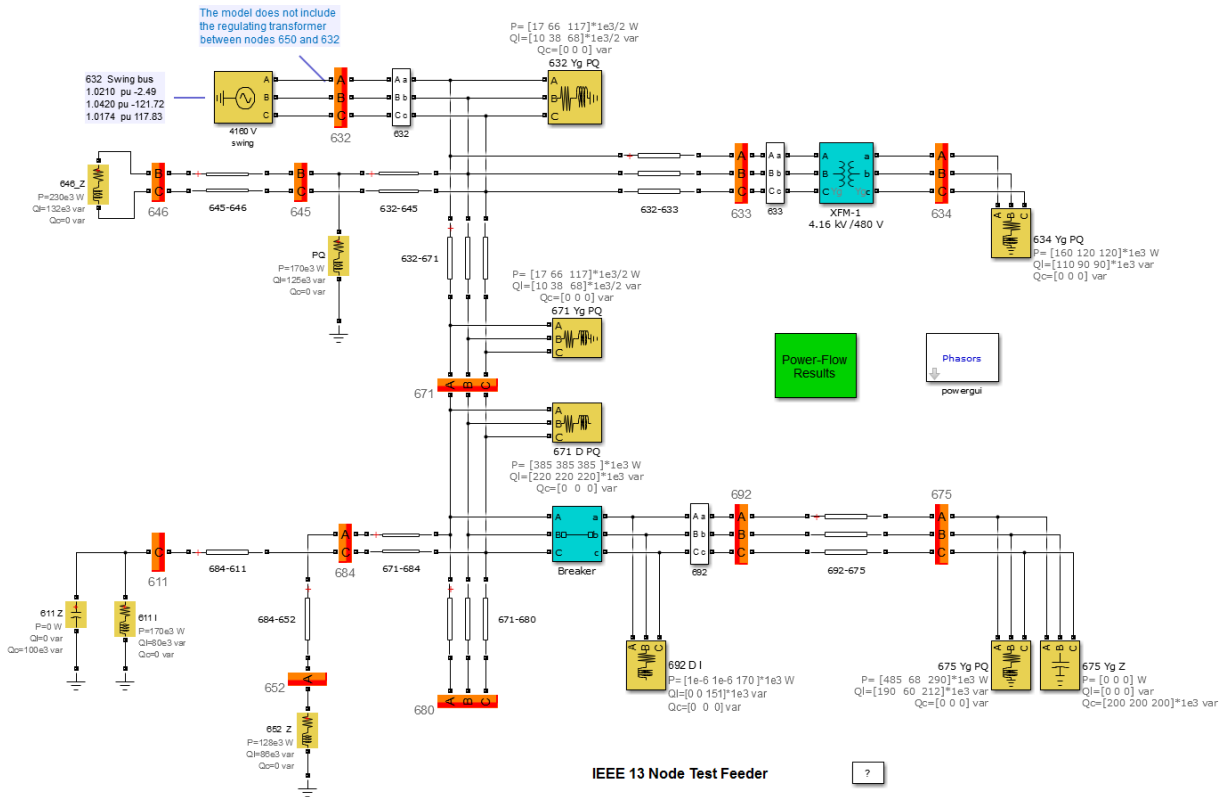

The Load Flow Bus blocks are shown in orange and the Load Flow blocks are shown in yellow.

The Load Flow Bus blocks specify the bus base voltages (nominal phase-to-ground rms voltage). They specify the voltage at PV buses or the voltage and angle of the swing buses. Once the load flow is solved, the Load Flow Bus block displays the bus voltage magnitude and phase angle as block annotations.

Note: By default the block annotations are set in the **Block Annotation** tab of the Load Flow Bus block properties to display the phase A magnitude (<VLF> parameter) and the phase A angle (<angleLFA> parameter). To display phase B magnitude and angle, specify <VLFb> and <angleLFB>, respectively. To display phase C magnitude and angle, specify <VLFc> and <angleLFC>, respectively.

You can also delete some block annotations. In the `power_13NodeTestFeeder` example, only the bus identification is displayed (<ID> parameter).

The bus type (PV, PQ, or swing) is determined by the load flow blocks connected to the bus. If you have several load flow blocks with different types (specified in the Generator type parameter or in the Load type parameter) connected to the same bus, the Load Flow tool determines the resulting bus type (swing, PQ, or PV). The table shows how the bus types are determined for some of the model buses of the `power_13NodeTestFeeder` example.

Bus	Load Flow Blocks	Resulting Bus Type
632	4160 V swing - Generator type = swing	632_a=swing V=1.0210 pu -2.49 deg. 632_b=swing V=1.042 pu -121.72 deg. 632_c=swing V=1.074 pu -121.72 deg. (Voltages and angles are specified in the '632' Load Flow Bus block)
633	No load flow block	PQ 633_a -> P= 0 kW; Q = 0 kvar 633_b -> P= 0 kW; Q = 0 kvar 633_c -> P= 0 kW; Q = 0 kvar
634	634 Yg PQ load block - Load type = constant PQ	PQ 634_a -> P= 160 kW; Q = 110 kvar 634_b -> P= 120 kW; Q = 90 kvar 634_c -> P= 120 kW; Q = 90 kvar
646	646_Z load block - Load type = constant Z - Load connection 'bc'	PQ 646_bc -> P= 0 MW Q = 0 Mvar (Constant Z loads are included in the Ybus admittance matrix.)
675	675 Yg PQ load - Load type = constant PQ 675 Yg Z load - Load type = constant Z	PQ 675_a -> P= 485 kW; Q = 190 kvar 675_b -> P= 68 kW; Q = 60 kvar 675_c -> P= 290 kW; Q = 212 kvar (Constant Z loads are included in the Ybus admittance matrix.)

Some restrictions apply when you have several source blocks and synchronous machines connected to the same load flow bus:

- You cannot connect two swing generators in parallel.
- You cannot connect a swing generator in parallel with a PV ideal voltage source
- You can connect only one PV generator with finite Q limits at a generation bus. However, you can have other PQ generators and loads connected on the same bus.

For more information on how to use the Load Flow Bus block in your model, see **Load Flow Bus** block.

Open the Load Flow Tool to Perform Load Flow Analysis

Open the Load Flow tool by clicking the **Load Flow** button in the powergui block. The tool displays a list of the individual single-phase buses (one bus per phase) found in the power_13NodeTestFeeder model. In the Load Flow tool, the load flow has not yet been performed, and the V_LF and Vangle_LF columns display zero values.

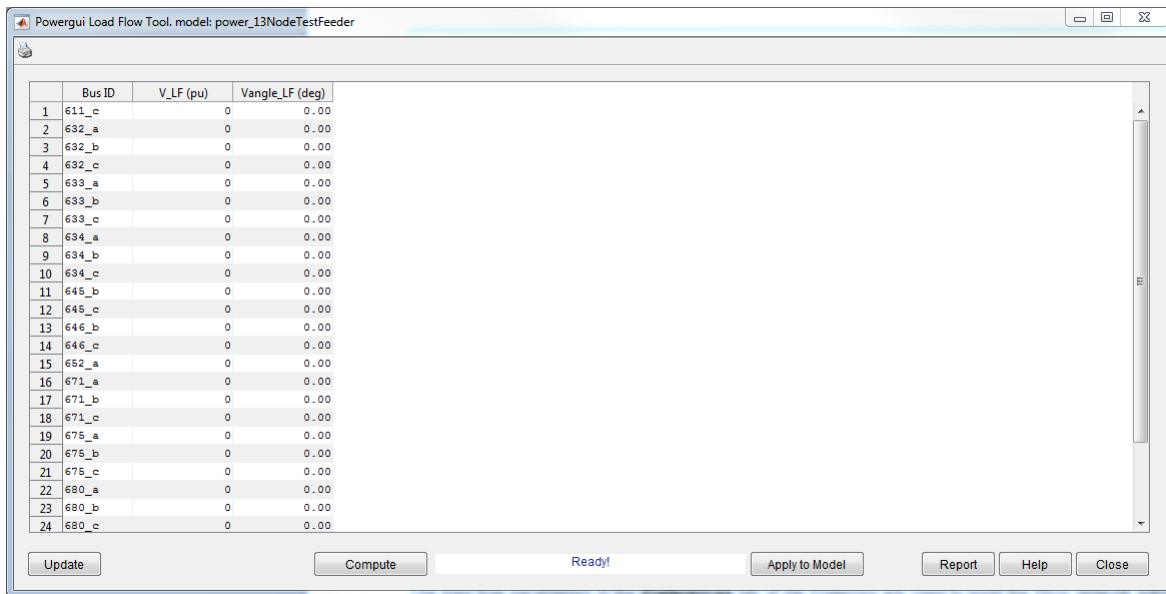

The screenshot shows the 'Powergui Load Flow Tool' window for the model 'power_13NodeTestFeeder'. The window contains a table with the following data:

	Bus ID	V_LF (pu)	Vangle_LF (deg)
1	611_c	0	0.00
2	632_a	0	0.00
3	632_b	0	0.00
4	632_c	0	0.00
5	633_a	0	0.00
6	633_b	0	0.00
7	633_c	0	0.00
8	634_a	0	0.00
9	634_b	0	0.00
10	634_c	0	0.00
11	645_b	0	0.00
12	645_c	0	0.00
13	646_b	0	0.00
14	646_c	0	0.00
15	662_a	0	0.00
16	671_a	0	0.00
17	671_b	0	0.00
18	671_c	0	0.00
19	675_a	0	0.00
20	675_b	0	0.00
21	675_c	0	0.00
22	680_a	0	0.00
23	680_b	0	0.00
24	680_c	0	0.00

At the bottom of the window, there are buttons for 'Update', 'Compute', 'Apply to Model', 'Report', 'Help', and 'Close'. The status bar shows 'Ready!'.

The load flow parameters in the **Preferences** tab of the Powergui are used to build the Ybus network admittance matrix and to solve the load flow. The base power is used to specify units of the normalized Ybus matrix in pu/Pbase and bus base voltages. The power_13NodeTestFeeder model contains 29 single phase buses; consequently, the

Ybus matrix is a 29x29 complex matrix evaluated at the frequency specified by the **Frequency (Hz)** parameter.

The load flow algorithm uses an iterative solution based on the Newton-Raphson method. The **Max iterations** parameter defines the maximum number of iterations. The load flow algorithm iterates until the P and Q mismatch at each bus is lower than the **PQ tolerance** parameter (in pu/Pbase). The power mismatch is defined as the difference between the net power injected into the bus by generators and PQ loads and the power transmitted on all links leaving that bus.

To avoid a badly conditioned Ybus matrix, select the **Base power** parameter value in the range of nominal powers and loads connected to the network. For a transmission network with voltages ranging from 120 kV to 765 kV, a 100 MVA base is usually selected. For a distribution network with loads having a nominal power in the range of tens to hundreds of kVA, a 100 kVA to 1 MVA power base is better adapted.

To solve the load flow, click **Compute**. The bus voltages and angles then appear in the V_LF and Vangle_LF columns of the table.

The screenshot shows the 'Powergui Load Flow Tool' window for a model named 'power_13NodeTestFeeder'. The main area contains a table with the following data:

Bus ID	V_LF (pu)	Vangle_LF (deg)
1 611_c	0.9741	115.76
2 632_a	1.0210	-2.49
3 632_b	1.0420	-121.72
4 632_c	1.0174	117.83
5 633_a	1.0178	-2.56
6 633_b	1.0402	-121.77
7 633_c	1.0148	117.83
8 634_a	0.9938	-3.24
9 634_b	1.0218	-122.22
10 634_c	0.9959	117.85
11 645_b	1.0329	-121.90
12 645_c	1.0154	117.86
13 646_b	1.0312	-121.98
14 646_c	1.0133	117.90
15 652_a	0.9796	-5.48
16 671_a	0.9871	-5.53
17 671_b	1.0519	-122.41
18 671_c	0.9780	116.00
19 675_a	0.9806	-5.77
20 675_b	1.0543	-122.58
21 675_c	0.9760	116.03
22 680_a	0.9871	-5.53
23 680_b	1.0519	-122.41
24 680_c	0.9780	116.00
25 684_a	0.9851	-5.55
26 684_c	0.9761	115.90
27 692_a	0.9871	-5.53
28 692_b	1.0519	-122.41
29 692_c	0.9780	116.00

At the bottom of the window, there are several buttons: 'Update', 'Compute', 'Apply to Model', 'Report', 'Help', and 'Close'. A status bar below the 'Compute' button displays the message 'Load Flow converged!'.

To display the load flow report showing the power flow at each bus, click **Report**. You can also save this report in a file by specifying the file name at the prompt.

The report starts with displaying the summary of active and reactive powers, showing total PQ sharing between generators (SM- and Vsrc-type blocks), PQ loads (PQ-type RLC loads, dynamic loads, and asynchronous machine loads), shunt constant Z loads (Z-type RLC loads and magnetizing branches of transformers):

SUMMARY for subnetwork No 1

Total generation	: P=	3518.74 kW	Q=	1540.14 kvar
Total PQ load	: P=	3101.90 kW	Q=	1880.42 kvar
Total Zshunt load	: P=	363.47 kW	Q=	-479.42 kvar
Total losses	: P=	53.36 kW	Q=	139.14 kvar

The **Total losses** line represents the difference between generation and loads (PQ type + Zshunt type). It therefore represents series losses. After this summary, a voltage and power report appears for each bus. For each phase of every bus, the bus voltage and angle are listed on the first line. The next three lines give the PQ generated at the bus (all SM and voltage sources), the PQ absorbed by the PQ type loads, and the PQ absorbed by the Z-type loads. The last lines, preceded by an arrow (\rightarrow), list the PQ power transmitted on all links leaving that bus.

The last column gives the positive-sequence bus voltage V1 (magnitude and angle, for three-phase buses only) and the sum of PQ powers for all phases (PQ generated by sources, PQ absorbed by loads, and PQ transmitted through transformers, lines, and series impedances). For example, you can verify that the total PQ load absorbed at bus 634 (P = 400 kW Q = 290 kvar) corresponds to the sum of active and reactive powers specified for phases A, B, and C in the load block.

Apply the Load Flow Solution to Your Model

When performing a load flow analysis, you might need to try different P, Q, and V values until you find satisfactory voltages at all buses. This can require, for example, changing generated power, load powers, or reactive shunt compensation.

To change the load flow setup, you need to edit the parameters of the load flow blocks and of the Load Flow Bus blocks. Then, click **Update** to refresh the load flow data displayed by the table. Click **Compute** to get a new load flow solution corresponding to the changes you made.

Once you have a satisfactory load flow, you need to update the model initial conditions according to the load flow solution. Click **Apply to Model** to initialize the PQ-type load

blocks, the source block internal voltages, the machine blocks, as well as the initial conditions of associated regulators.

Open the Three-Phase Series RLC Load block connected at bus 632. As the **Load type** specified in the **Load Flow** tab is constant PQ, the vector of **Nominal phase-to-neutral voltages [Va Vb Vc]** of this block has been changed to the corresponding bus voltages $[1.021 \ 1.042 \ 1.0174] * 2401.78$ Vrms . Open the Three-Phase Source block connected at bus 632. The **Line-to neutral voltages [Va Vb Vc]** parameter is also set to $[1.021 \ 1.042 \ 1.0174] * 2401.78$ Vrms.

Open the Power Flow Results subsystem and start the simulation.

Observe voltage magnitudes and PQ powers on various Display blocks. These values correspond to values displayed in the load flow report.

Performing Load Flow Analysis at the Command Line

As an alternative to using the Load Flow tool interface to perform a load flow, you can use the tool at the command line. For example, to perform the positive-sequence load flow on the `power_LFnetwork_5bus` model, enter:

```
LF = power_loadflow('-v2','power_LFnetwork_5bus','solve')
```

```
LF =  
    model: 'power_LFnetwork_5bus'  
    frequency: 60  
    basePower: 100000000  
    tolerance: 0.0001  
    Ybus1: [5x5 double]  
    bus: [1x7 struct]  
    sm: [1x1 struct]  
    asm: [1x1 struct]  
    vsrc: [1x1 struct]  
    pqload: [1x1 struct]  
    rlcload: [1x2 struct]  
    Networks: [1x1 struct]  
    status: 1  
    iterations: 2  
    error: ''  
    LoadFlowSolver: 'PositiveSequence'
```

The `power_loadflow` function returns the solution in the LF structure, and the model is initialized to start in steady state. You can obtain a detailed load flow report by entering:

```
LF = power_loadflow('-v2','power_LFnetwork_5bus','solve','report');
```

The function prompts you to save the report in a file that is displayed in the MATLAB editor.

You can use the same command to perform an unbalanced load flow on the `power_13NodeTestFeeder` model:

```
LF = power_loadflow('-v2','power_13NodeTestFeeder','solve')
```

```
LF =
    model: 'power_13NodeTestFeeder'
  frequency: 60
  basePower: 100000
  tolerance: 0.0001
    Ybus: [29x29 double]
    bus: [1x29 struct]
      sm: [1x1 struct]
      asm: [1x1 struct]
      vsrc: [1x1 struct]
      pqload: [1x1 struct]
      rlcload: [1x1 struct]
    Networks: [1x1 struct]
    status: 1
  iterations: 3
    error: ''
  LoadFlowSolver: 'Unbalanced'
```

For more information on how to use the `power_loadflow` function in your code and for detailed information on the LF structure, see `power_loadflow`.

Using the Phasor Solution Method for Stability Studies

Up to now, you have simulated a relatively simple power system consisting of a maximum of three machines. If you increase complexity of your network by adding extra lines, loads, transformers, and machines, the required simulation time becomes

longer and longer. Moreover, if you are interested in slow electromechanical oscillation modes (typically between 0.02 Hz and 2 Hz on large systems) you might have to simulate for several tens of seconds, implying simulation times of minutes and even hours. The conventional continuous or discrete solution method is therefore not practical for stability studies involving low-frequency oscillation modes. To allow such studies, you have to use the phasor technique (see “Introducing the Phasor Simulation Method” on page 1-31).

For a stability study, we are not interested in the fast oscillation modes resulting from the interaction of linear R, L, C elements and distributed parameter lines. These oscillation modes, which are usually located above the fundamental frequency of 50 Hz or 60 Hz, do not interfere with the slow machine modes and regulator time constants. In the phasor solution method, these fast modes are ignored by replacing the network's differential equations by a set of algebraic equations. The state-space model of the network is therefore replaced by a transfer function evaluated at the fundamental frequency and relating inputs (current injected by machines into the network) and outputs (voltages at machine terminals). The phasor solution method uses a reduced state-space model consisting of slow states of machines, turbines, and regulators, thus dramatically reducing the required simulation time. Continuous variable-step solvers are very efficient in solving this type of problem. Recommended solver is `ode23tb` with a maximum time step of one cycle of the fundamental frequency (1/60 s or 1/50 s).

Now apply the phasor solution method to the two-machine system you have just simulated with the conventional method. Open the `power_machines` example.

Double-click the Powergui, click **Configure Parameters**, and in the powergui block parameters dialog box set **Simulation type** to **Phasor**. You must also specify the fundamental frequency used to solve the algebraic network equations. A default value of 60 Hz should already be entered in the **Phasor frequency** field. Close the Powergui and notice that the word **Phasors** now appears on the Powergui icon, indicating that this new method can be used to simulate your circuit. To start the simulation in steady state, you must first repeat the machine initialization procedure explained in the previous section, “Machine Initialization Tool” on page 2-25.

In the **Configuration Parameters** dialog box, specify a **Max step size** of 1/60 s (one cycle) and start the simulation.

Observe that simulation is now much faster. The results compare well with those obtained with the continuous mode simulation. A comparison of synchronous machine and asynchronous machine signals is shown below.

Continuous simulation

Name	Color
Is_abc.ias	—
RPM:1	—
Pm	—
Vt	—

Phasor simulation

Name	Color
Is_abc.ias	—
RPM:1	—
Pm	—
Vt	—

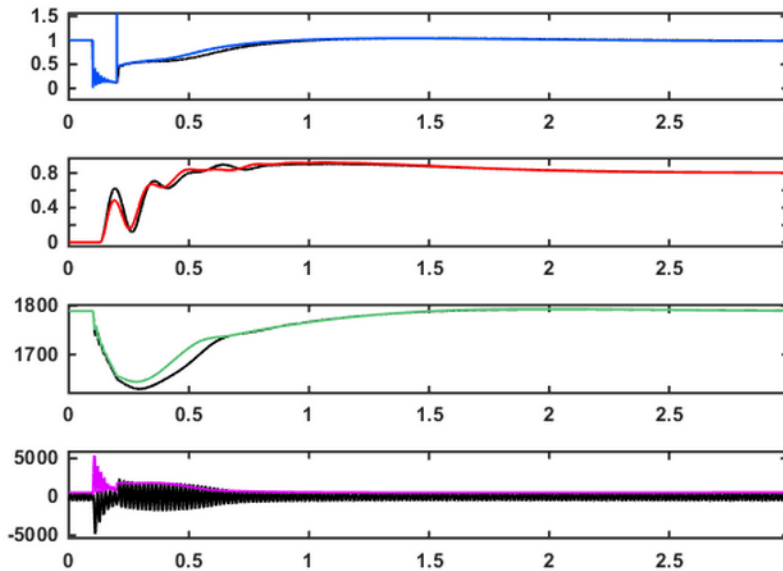

Comparison of Results for Continuous and Phasor Simulation Methods

The phasor solution method is illustrated on more complex networks presented as the following examples:

- Transient stability of two machines with power system stabilizers (PSS) and a static var compensator (SVC) (`power_svc_pss` model)
- Performance of three power system stabilizers for interarea oscillations (`power_PSS` model)

The first example illustrates the impact of PSS and use of a SVC to stabilize a two-machine system. The second example compares the performance of three different types of power system stabilizers on a four-machine, two-area system.

The phasor solution method is also used for FACTS models available in the `factslib` library. See the case studies “Improve Transient Stability Using SVC and PSS” on page 6-2 and “Control Power Flow Using UPFC and PST” on page 6-8.

Building and Customizing SimPowerSystems Models

In this section...

“Introduction” on page 2-49

“Modeling a Nonlinear Inductance” on page 2-49

“Modeling a Nonlinear Resistance” on page 2-54

“Connecting Your Model with Other Nonlinear Blocks” on page 2-57

Introduction

SimPowerSystems Specialized Technology provides a wide collection of models. It can happen, however, that you need to interface your own model with the standard models provided in the Specialized Technology library. This model could be a simple nonlinear resistance simulating an arc or a varistor, a saturable inductor, a new type of motor, etc.

In the following sections, a simple saturable inductance and a nonlinear resistance serve as examples.

Modeling a Nonlinear Inductance

Consider an inductor of 2 henries designed to operate at a nominal voltage, $V_{nom} = 120$ V RMS, and a nominal frequency, $f_{nom} = 60$ Hz. From zero to 120 V RMS the inductor has a constant inductance, $L = 2$ H. When voltage exceeds its nominal voltage, the inductor saturates and its inductance is reduced to $L_{sat} = 0.5$ H. The nonlinear flux-current characteristic is plotted in the next figure. Flux and current scales are in per units. The nominal voltage and nominal current are chosen as base values for the per-unit system.

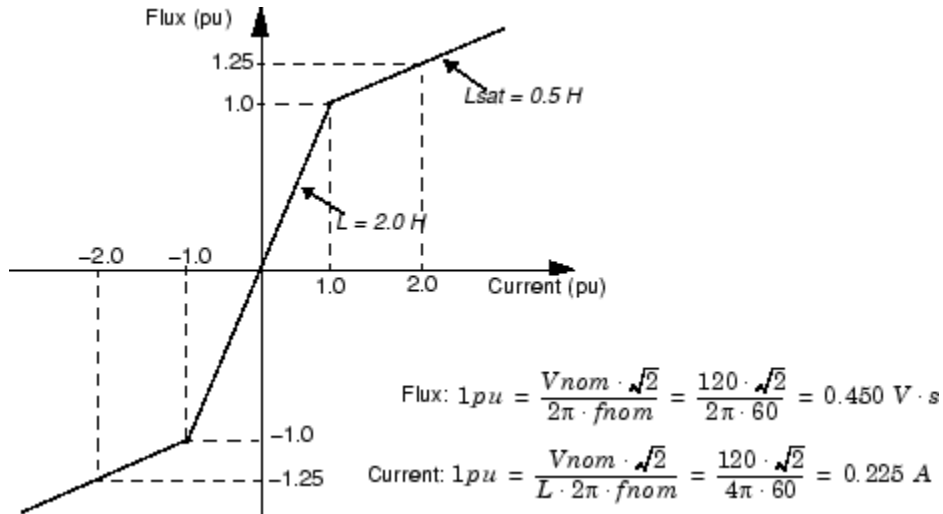

Flux-Current Characteristic of the Nonlinear Inductance

The current i flowing in the inductor is a nonlinear function of flux linkage ψ that, in turn, is a function of v appearing across its terminals. These relations are given by the following equations:

$$v = L \cdot \frac{di}{dt} = \frac{d\psi}{dt} \quad \text{or} \quad \psi = \int v \cdot dt$$

$$i = \frac{\psi}{L(\psi)}$$

The model of the nonlinear inductance can therefore be implemented as a controlled current source, where current i is a nonlinear function of voltage v , as shown.

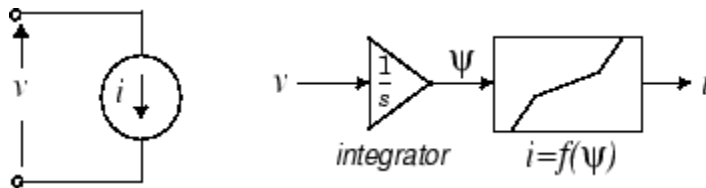

Model of a Nonlinear Inductance

Implementation of a Nonlinear Inductance shows a circuit using a 2 H nonlinear inductance. The nonlinear inductance is connected in series with two voltage sources (an AC Voltage Source block of 120 volts RMS, 60 Hz, and a DC Voltage Source block) and a 5 ohm resistor.

All the elements used to build the nonlinear model have been grouped in a subsystem named Nonlinear Inductance. The inductor terminals are labeled In and Out. A Simulink output returning the flux has been added to the subsystem. You can connect this output to a Scope block to observe the flux.

The nonlinear model uses a Voltage Measurement block to read the voltage at the inductance terminals and a Controlled Current Source block. The direction of the arrow of the current source is oriented from input to output according to the model shown above.

An Integrator block computes the flux from the voltage input, and a 1-D Lookup Table block implements the saturation characteristic $i = f(\psi)$ described by Flux-Current Characteristic of the Nonlinear Inductance.

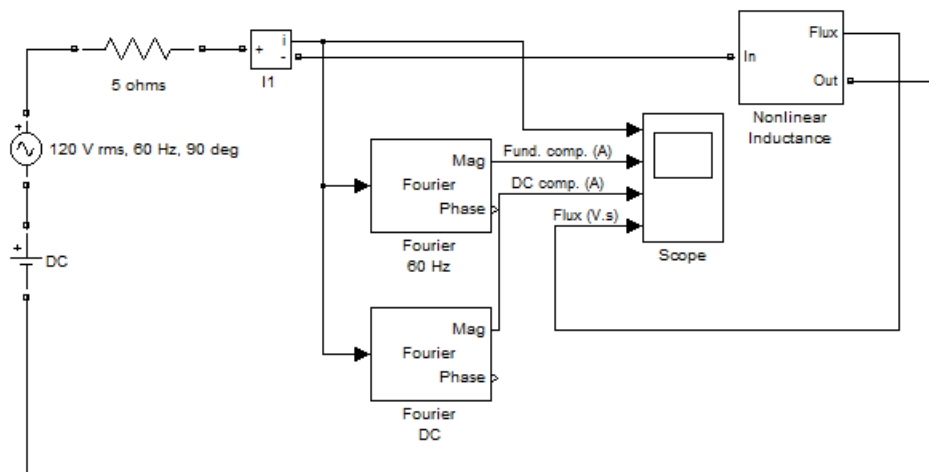

Implementation of a Nonlinear Inductance

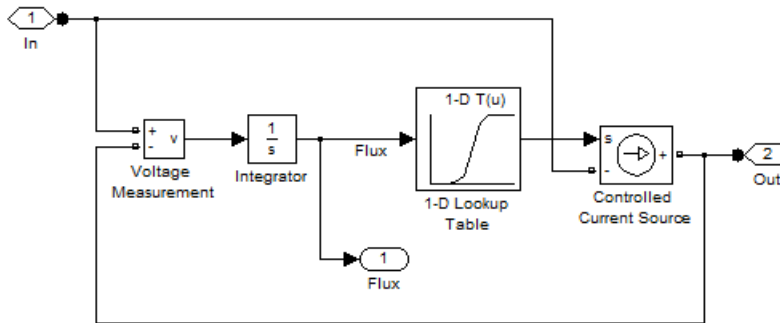

Nonlinear Inductance subsystem

Two Fourier blocks from the Control and Measurements/Measurements library are used to analyze the fundamental component and the DC component of the current.

Using blocks of the SimPowerSystems Specialized Technology and Simulink libraries, build the circuit shown above. To implement the $i = f(\psi)$ relation, specify the following vectors in the 1-D Lookup Table block:

Breakpoints 1 (flux)	$[-1.25 \ -1 \ 1 \ 1.25] \cdot (120 \cdot \sqrt{2}) / (2 \cdot \pi \cdot 60)$
Table data (current)	$[-2 \ -1 \ 1 \ 2] \cdot (120 \cdot \sqrt{2}) / (4 \cdot \pi \cdot 60)$

Set the following parameters for the two sources:

AC source		
	Peak amplitude	$120 \cdot \sqrt{2}$
	Phase	90 degrees
	Frequency	60 Hz
DC source		
	Amplitude	0 V

Adjust the simulation time to 1.5 s and select the ode23tb integration algorithm with default parameters. Start the simulation.

As expected, the current and the flux are sinusoidal. Their peak values correspond to the nominal values.

$$Peak\ Current = \frac{120 \cdot \sqrt{2}}{2 \cdot 2\pi \cdot 60} = 0.225\ A$$

$$Peak\ Flux = \frac{120 \cdot \sqrt{2}}{2\pi \cdot 60} = 0.450\ V \cdot s$$

Now change the DC voltage to 1 V and restart the simulation. Observe that the current is distorted. The 1 V DC voltage is now integrated, causing a flux offset, which makes the flux enter into the nonlinear region of the flux-current characteristic ($\psi > 0.450\ V \cdot s$). As a result of this flux saturation, the current contains harmonics. Zoom in on the last three cycles of the simulation. The peak value of the current now reaches 0.70 A and the fundamental component has increased to 0.368 A. As expected, the DC component of the current is $1\ V / 0.5\ \Omega = 0.2$.

You can create a mask that specifies the following prompts, variables, and values:

Nominal voltage (Volts rms):	Vnom	120
Nominal frequency (Hz):	fnom	60
Unsatrated inductance (H):	L	2
Saturation characteristic [i1(pu) phi1(pu); i2 phi2; ...]:	sat	[0, 0; 1, 1; 2, 1.25]

The following code in the mask initializations of the block prepares the two vectors Current_vect and Flux_vect to be used in the Look-Up Table block of the model.

```
% Define base current and Flux for pu system
I_base = Vnom*sqrt(2)/(L*2*pi*fnom);
Phi_base = Vnom*sqrt(2)/(2*pi*fnom);

% Check first two points of the saturation characteristic
if ~all(all(sat(1:2,:) == [0 0; 1 1])),
    h=errordlg('The first two points of the characteristic must
be [0 0; 1 1]', 'Error');
    uiwait(h);
end
```

```
% Complete negative part of saturation characteristic
[npoints,ncol]=size(sat);
sat1=[sat ; -sat(2:npoints,:)];
sat1=sort(sat1);

% Current vector (A) and flux vector (V.s)
Current_vect=sat1(:,1)*I_base;
Flux_vect=sat1(:,2)*Phi_base;
```

As the saturation characteristic is specified only in the first quadrant, three lines of code are added to complete the negative part of the saturation characteristic. Notice also how the validity of the first segment of the saturation characteristic is verified. This segment must be defined by two points [0 0; 1 1] specifying a 1 pu inductance (nominal value) for the first segment.

Modeling a Nonlinear Resistance

The technique for modeling a nonlinear resistance is similar to the one used for the nonlinear inductance.

A good example is a metal-oxide varistor (MOV) having the following V-I characteristic:

$$i = I_0 \cdot \left(\frac{v}{V_0} \right)^\alpha$$

where

$v, i =$	Instantaneous voltage and current
$V_0 =$	Protection voltage
$I_0 =$	Reference current used to specify the protection voltage
$\alpha =$	Exponent defining the nonlinear characteristic (typically between 10 and 50)

The following figure shows an application of such a nonlinear resistance to simulate a MOV used to protect equipment on a 120 kV network. To keep the circuit simple, only one phase of the circuit is represented.

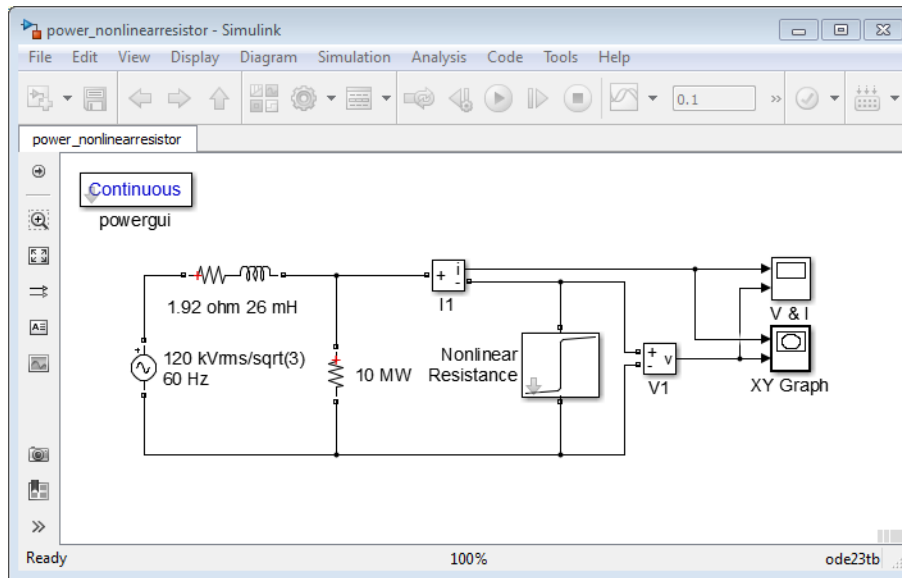

Nonlinear Resistance Applied on a 120 kV Network

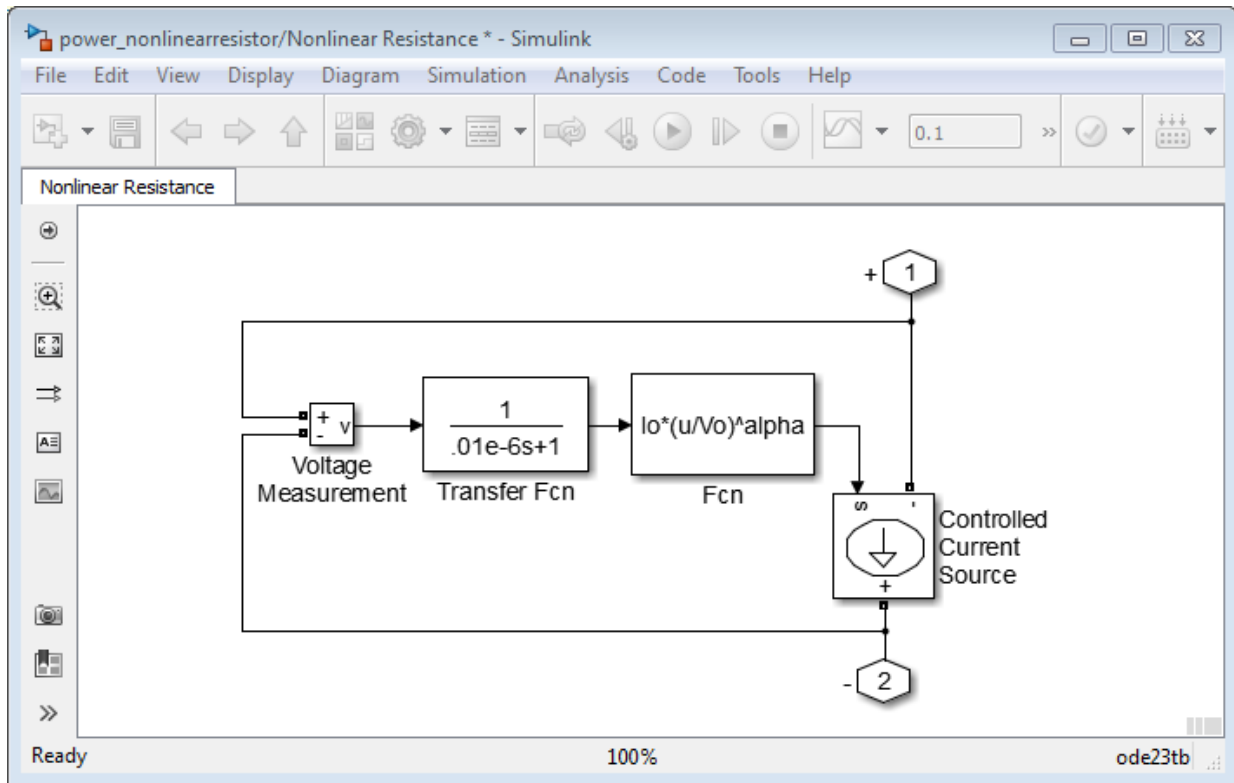

This model is available in the `power_nonlinearresistor` example.

The model does not use a Look-Up Table block as in the case of the nonlinear inductance model. As the analytical expression of current as a function of voltage is known, the nonlinear $I(V)$ characteristic is implemented directly with a Fcn block from the Simulink library.

This purely resistive model contains no states. It produces an algebraic loop in the state-space representation of the circuit.

Algebraic loops often lead to slow simulation times. You should break the loop with a block that does not change the nonlinear characteristic. Here a first-order transfer function $H(s) = 1/(1+Ts)$ is introduced into the system, using a fast time constant ($T = 0.01 \mu\text{s}$).

Connecting Your Model with Other Nonlinear Blocks

Nonlinear models implemented as a current source cannot be connected in series with an inductor, another current source, or an open circuit. Such circuit topologies cause errors in SimPowerSystems.

Similarly, if your nonlinear model uses a **Controlled Voltage Source** block, this model could not be short-circuited or connected across a capacitor.

Suppose, for example, that you want to study the inrush current in the nonlinear resistance of the `power_nonlinearresistor` example model when it is energized on a voltage source:

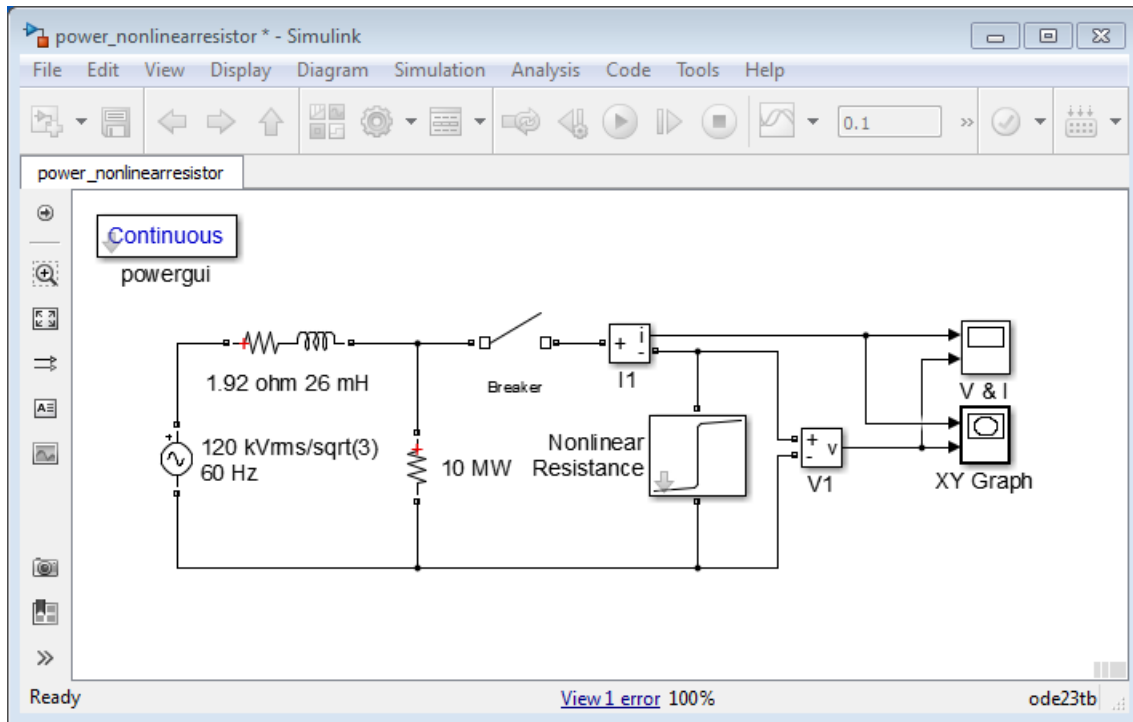

Circuit Topology Causing an Error

If you try to simulate this circuit, you get the following error message:

✘ The following two blocks cannot be connected in series because they are modeled as current sources:

Block 1: Breaker

Block 2: Nonlinear Resistance/Controlled Current Source

Add a high-value resistance in parallel with one of the two block.

You can also specify high-value resistive snubbers if the blocks have a snubber device. You can also avoid the use of the snubbers by selecting the 'Enable use of ideal switching devices' option of powergui block.

This topology is forbidden because two nonlinear elements simulated by current sources are connected in series: the **Breaker** block and the Nonlinear Inductance block. To be able to simulate this circuit, you must provide a current path around one of the two nonlinear blocks. You could, for example, connect a large resistance, say $1\text{ M}\Omega$, across the Breaker block or the Inductance block. In this case, it is more convenient to choose the Breaker block because a series RC snubber circuit is provided with the model.

Note Using an inductive source impedance (R-L series) instead of a purely resistive impedance would have produced another error message, because the current source modeling the nonlinear inductance would have been in series with an inductance, even with a resistive snubber connected across the breaker. In such a case, you could add either a parallel resistance across the source impedance or a large shunt resistance connected between one breaker terminal and the source neutral terminal.

Building a Model Using Model Construction Commands

This section shows you how to use model construction commands to add blocks to your models and connect them.

Suppose you want to add a PI Section Line block and a Voltage Measurement block to your model, connect the + terminal of the Voltage Measurement block to the left end of the PI Section Line block, and connect the - terminal of the Voltage Measurement block to the right end of the PI Section Line block.

The following code shows you how to add and position the two blocks in your model.

```
add_block('powerlib/Elements/Pi Section Line','Mymodel/Block1');
add_block('powerlib/Measurements/Voltage Measurement',
'Mymodel/Block2');
set_param('Mymodel/Block1','position',[340,84,420,106]);
set_param('Mymodel/Block2','position',[520,183,545,207]);
```

For each block you want to connect, you need to know the handles of the terminal ports.

```
Block1PortHandles = get_param('Mymodel/Block1','PortHandles');
Block2PortHandles = get_param('Mymodel/Block2','PortHandles');
```

The `add_line` command uses the `RConn` and `LConn` fields of the `Block1PortHandles` and `Block2PortHandles` structure variables to connect the blocks. The `RConn` field represents the right connectors of the blocks and the `LConn` field represents the left connectors. You then need to specify to the `add_line` command the indices of the connectors you want to connect.

```
add_line('Mymodel',Block1PortHandles.LConn(1),
Block2PortHandles.LConn(1));
add_line('Mymodel',Block1PortHandles.RConn(1),
Block2PortHandles.LConn(2));
```

Improving Simulation Performance

- “How SimPowerSystems Software Works” on page 3-2
- “Choosing an Integration Method” on page 3-5
- “Simulating with Continuous Integration Algorithms” on page 3-7
- “Simulating Discretized Electrical Systems” on page 3-14
- “Increasing Simulation Speed” on page 3-20
- “Creating Your Own Library of Models” on page 3-22
- “Change Circuit Parameters” on page 3-23

How SimPowerSystems Software Works

Every time you start the simulation, a special initialization mechanism is called. This initialization process computes the state-space model of your electric circuit and builds the equivalent system that can be simulated by Simulink software. This process performs the following steps:

- 1 Sorts all SimPowerSystems blocks, gets the block parameters and evaluates the network topology. The blocks are separated into linear and nonlinear blocks. Each electrical node is automatically given a node number.
- 2 Once the network topology has been obtained, the state-space model (A, B, C, D matrices) of the linear part of the circuit is computed. All steady-state calculations and initializations are performed at this stage.

If you have chosen to discretize your circuit, the discrete state-space model is computed from the continuous state-space model.

If you are using the phasor solution method, the state-space model is replaced with the complex transfer matrix $H(j\omega)$ relating inputs and outputs (voltage and current phasors) at the specified frequency. This matrix defines the network algebraic equations.

- 3 Builds the Simulink model of your circuit and stores it inside the Powergui block located at the top level of your model.

The Simulink model uses an S-Function block to model the linear part of the circuit as well as the switches and power electronic devices. Predefined Simulink models are used to simulate nonlinear elements. Simulink Source blocks connected at the input of the State-Space block are used to simulate the electrical source blocks.

The next figure represents the interconnections between the different parts of the complete Simulink model. The nonlinear models are connected in feedback between voltage outputs and current inputs of the linear model.

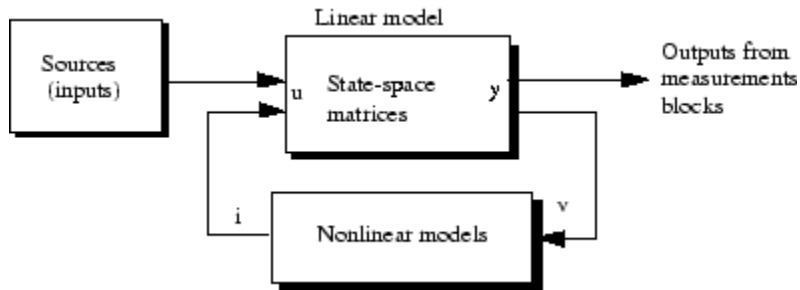

Interconnection of Linear Circuit and Nonlinear Models

Once SimPowerSystems software has completed the initialization process, the simulation starts. You can observe waveforms on scopes connected at the outputs of your measurement blocks. Through the Powergui block, you can access the Linear System Analyzer and obtain transfer functions of your system between any pair of input and output. The Powergui block also allows you to perform a FFT analysis of recorded signals to obtain their frequency spectrum.

If you stop the simulation and double-click the Powergui block, you have access to the steady-state values of inputs, outputs, and state variables displayed as phasors. You can also use the Powergui block to modify the initial conditions. The Powergui block interface allows you to perform a load flow with circuits involving three-phase machinery and initialize the machine models so that the simulation starts in steady state. This feature avoids long transients due to mechanical time constants of machines. The Powergui block allows you to specify the frequency range that you want, visualize impedance curves, and store results in your workspace for Impedance Measurement blocks connected in your circuit.

Limitations of the Nonlinear Models

Because nonlinear models are simulated as current sources, they cannot be connected in series with inductors and their terminals cannot be left open.

If you feed a machine through an inductive source, SimPowerSystems prompts you with an error message. You can avoid this error by connecting large resistances in parallel with the source inductances or across the machine terminals.

A series RC snubber circuit is included in the model of the Breaker block and power electronics blocks. If you keep these snubber circuits in service, you do not encounter any

issues. The snubber can be changed to a single resistance by setting **Cs** to **Inf**, or to a single capacitor by setting **Rs** = **0**. To eliminate the snubber, specify **Rs** = **Inf** or **Cs** = **0**.

Choosing an Integration Method

In this section...

“Introduction” on page 3-5

“Continuous Versus Discrete Solution” on page 3-5

“Phasor Solution Method” on page 3-5

Introduction

Three solution methods are available through the **Powergui** block. These are:

- Continuous solution method using Simulink variable-step solvers
- Discretization for solution at fixed time steps
- Phasor solution method using Simulink variable-step solvers

Continuous Versus Discrete Solution

One important feature of SimPowerSystems software is its ability to simulate electrical systems either with continuous variable-step integration algorithms or with a fixed-step using a discretized system. For small size systems, the continuous method is usually more accurate. Variable-step algorithms are also faster because the number of steps is fewer than with a fixed-step method giving comparable accuracy. When using line-commutated power electronics, the variable-step, event-sensitive algorithms detect the zero crossings of currents in diodes and thyristors with a high accuracy so that you do not observe any current chopping. However, for large systems (containing either a large number of states or nonlinear blocks), the drawback of the continuous method is that its extreme accuracy slows down the simulation. In such cases, it is advantageous to discretize your system.

You can consider small size a system that contains fewer than 50 electrical states and fewer than 25 electronic switches. Circuit breakers do not affect the speed much, because these devices are operated only a couple of times during a test.

Phasor Solution Method

If you are interested only in the changes in magnitude and phase of all voltages and currents when switches are closed or opened, you do not need to solve all differential

equations (state-space model) resulting from the interaction of R, L, C elements. You can instead solve a much simpler set of algebraic equations relating the voltage and current phasors. The phasor solution method solves a much simpler set of equations. As its name implies, this method computes voltages and currents as phasors. The phasor solution method is particularly useful for studying transient stability of networks containing large generators and motors. In this type of problem, you are interested in electromechanical oscillations resulting from interactions of machine inertias and regulators. These oscillations produce a modulation of the magnitude and phase of fundamental voltages and currents at low frequencies (typically between 0.02 Hz and 2 Hz). Long simulation times are therefore required (several tens of seconds). The continuous or discrete solution methods are not appropriate for this type of problem.

In the phasor solution method, the fast modes are ignored by replacing the network differential equations by a set of algebraic equations. The state-space model of the network is replaced by a complex matrix evaluated at the fundamental frequency and relating inputs (currents injected by machines into the network) and outputs (voltages at machine terminals). As the phasor solution method uses a reduced state-space model consisting of slow states of machines, turbines and regulators, it dramatically reduces the required simulation time.

Continuous variable-step solvers are very efficient in solving this type of problem. Recommended solver is `ode23tb` with a maximum time step of one cycle of the fundamental frequency (1/60 s or 1/50 s). This faster solution technique gives the solution only in the vicinity of the fundamental frequency.

Simulating with Continuous Integration Algorithms

In this section...

“Choosing an Integration Algorithm” on page 3-7

“Simulating Switches and Power Electronic Devices” on page 3-8

“Using the Ideal Switching Device Method” on page 3-8

Choosing an Integration Algorithm

Simulink software provides a variety of solvers. Most of the variable-step solvers work well with linear circuits. However circuits containing nonlinear models, especially circuits with circuit breakers and power electronics, require stiff solvers.

Best accuracy and fastest simulation speed is usually achieved with `ode23tb`.

Solver	<code>ode23tb</code>
Relative tolerance	<code>1e-4</code>
Absolute tolerance	<code>auto</code>
Maximum step size	<code>auto</code>
Initial step size	<code>auto</code>
Solver reset method	<code>fast</code>

Normally, you can choose `auto` for the absolute tolerance and the maximum step size. In some instances you might have to limit the maximum step size and the absolute tolerance. Selecting too small a tolerance can slow down the simulation considerably. The choice of the absolute tolerance depends on the maximum expected magnitudes of the state variables (inductor currents, capacitor voltages, and control variables).

For example, if you work with high-power circuit where expected voltage and currents are thousands of volts and amperes, an absolute tolerance of 0.1 or even 1.0 is sufficient for the electric states. However, if your electrical circuit is associated with a control system using normalized control signals (varying around 1), the absolute tolerance is imposed by the control states. In this case, choosing an absolute tolerance of `1e-3` (1% of control signal) would be appropriate. If you are working with a very low power circuit with expected currents of milliamperes, set the absolute tolerance to `1e-6`.

Note Usually, keeping the **Solver reset method** parameter of the ode23tb solver to its default value (**Fast**) produces the best simulation performance. However, for some highly nonlinear circuits it might be necessary to set this parameter to **Robust**. When you build a new model, we recommend that you try both the **Robust** and the **Fast** reset methods. If you do not notice a difference in simulation results, then keep the **Fast** method, which provides fastest simulation speed.

Simulating Switches and Power Electronic Devices

Three methods are available for continuous simulation of switches and power electronic devices:

- Purely resistive switch — The switch and the linear elements are simulated as a variable topology circuit. The state-space model of the circuit is recalculated at each switch opening or closing. When the switch is in series with an inductive element, a snubber is required.
- Ideal switch — The switch is modeled using the Ideal Switching Device method. The state-space model of the circuit is recalculated at each switch opening or closing. Snubbers are not required.
- Inductive switch — The switch contains a series inductance (Diode and Thyristor with $L_{on} > 0$, IGBT, MOSFET, or GTO). The switch is simulated as a current source driven by voltage across its terminals. The nonlinear element (with a voltage input and a current output) is then connected in feedback on the linear circuit, as shown in the Interconnection of Linear Circuit and Nonlinear Models.

Note You have the choice to simulate diodes and thyristors with or without L_{on} internal inductance. In most applications, it is not necessary to specify an inductance L_{on} . However, for certain circuit topologies, you might have to specify a switch inductance L_{on} to help commutation.

Using the Ideal Switching Device Method

Modeling switches, such as circuit breakers or power electronic devices, as current sources implies that the on-state switch resistance R_{on} cannot be zero. Also, as switches are modeled by a current source, they cannot be connected in series with an inductive circuit or with another switch or current source. In such a case, you must add a circuit (R or RC snubber) in parallel with the switches so that their off-state impedance has a finite value. If the real circuit does not use snubbers, or if you want to simulate ideal

switches with no snubber, you must at least use resistive snubbers with a high resistance value to introduce a negligible leakage current. The drawback of introducing such high-impedance snubbers is that the large difference between the on-state and the off-state switch impedance produces a stiff state-space model. For example, if a 1 H inductance is connected to a voltage source by a switch having a on-state resistance $R_{on} = 0.001$ ohms and a snubber resistance $R_s = 1e6$ ohms, the time constant L/R of this first order circuit varies from 1000 s when the switch is closed to 1 μ s when the switch is open. If you simulate this circuit with a continuous solver, such a wide range of time constants requires a variable-step stiff solver such as `ode23tb`. The model stiffness affects the simulation speed. If the snubber resistances are too large, the solver might become extremely slow or even fail to find a solution. If you are using a discretized model, you might observe numerical oscillations if your sample time is too large.

When you model switches using the Ideal Switching Device method, snubbers are not required. To enable this method:

- 1 Open the Powergui dialog box and select **Configure parameters**. The Powergui block parameters dialog box opens.
- 2 In the **Solver** tab of this dialog box, set the **Simulation type** parameter to **Continuous** and select **Enable use of ideal switching devices**.

Additional options are displayed, allowing you to disable switch snubbers, as well as their R_{on} resistance ($R_{on}=0$) and their forward voltage ($V_f=0$), when applicable.

You can select **Disable snubbers in switching devices**, which disables snubbers of all switches. Otherwise, you may individually disable snubbers of selected switches by specifying $R_s = \text{inf}$ in their block menus. You can also simulate perfectly ideal switches by disabling the resistances (R_{on}) and the forward voltages (V_f).

Eliminating the snubbers reduces the circuit stiffness and lets you use a non-stiff solver, for example, `ode45` instead of `ode23tb`, to achieve correct results and good simulation speed.

State-Space Equations

Assuming a circuit containing n_x states, n_s switches, and n_y voltage or current outputs, the software determines:

- n_x state derivatives to be computed from the A and B matrices of

$$\dot{x} = A \cdot x + B \cdot u$$

- n_s switch variables (either voltages across open switches or currents through closed switches)
- n_y output variables to be computed from the C and D matrices of

$$y = C \cdot x + D \cdot u$$

A total of $n_x + n_s + n_y$ equations is obtained.

Unknown variables are state derivatives dx/dt , outputs y , and switch variables (switch voltages or switch currents). Known variables are state variables x and inputs u (voltage sources or current sources).

As the switch status (open or closed) is undetermined, circuit equations are expressed using both switch voltages (v_{D1} , v_{D2}) and switch currents (i_{D1} , i_{D2}).

These equations express Kirchhoff current laws (KCL) at circuit nodes and Kirchhoff voltage laws (KVL) for the independent loops. These equations are completed by the output equations.

Computation of the state-space model is incorporated in an S-function and performed each time a switch status is changing.

To get a list of the circuit equations in the Command Window, select the **Display circuit differential equations** check box in the **Solver** tab of the Powergui block parameters dialog box.

Limitations

Continuous Solver Required

The Ideal Switching Device method is not supported with discretized models.

Specifications of Snubber Values

This method was developed to avoid use of snubbers across switches. However, the method still works when you use snubbers. For example, models of the Power Electronic Models examples will work when you keep snubbers, Ron and Vf, in service.

For discretized models, in the Powergui block, change the **Simulation type** from **Discrete** to **Continuous** and select **Enable use of ideal switching devices**. Then specify a continuous solver (recommended solver: `ode23tb` with relative tolerance $1e-4$).

If you specify resistive snubber values that are too large, the circuit model might become badly conditioned and cause the simulation to stop. In such a case, reduce snubber resistances so that the resulting leakage current remains acceptable (for example 0.01% to 0.1% of switch nominal current).

Specification of R_{on} When V_f is Greater Than Zero

In some circuits, using switches with a forward voltage V_f greater than zero and $R_{on}=0$ might cause simulation to stop and display an error message due to a State-Source dependency. To avoid this problem, specify a small R_{on} value.

Example

Consider the full-wave rectifier shown in the following figure.

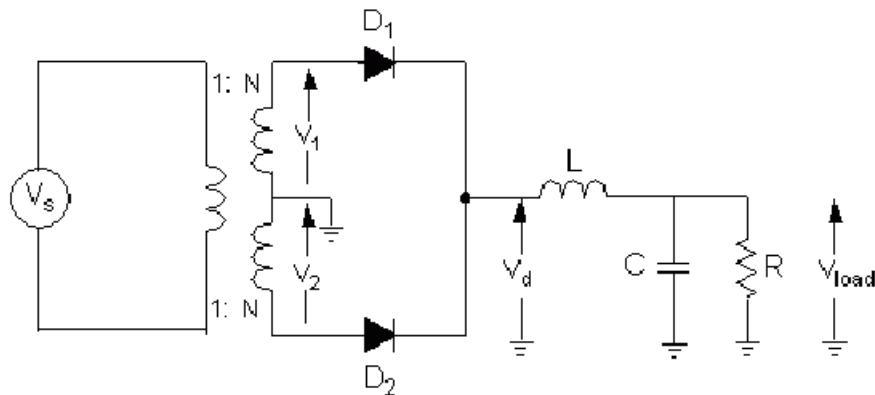

Full-Wave Rectifier

When you simulate this circuit without using the ideal switching method, you must use snubbers across diodes D1 and D2 because these elements are connected in series with inductances (transformer leakage inductances of the two secondary windings and filter inductance L). Otherwise, when you start the simulation SimPowerSystems prompts an error message.

- 1 Open the `power_FullWaveRectifier` example. The parameters are typical for a 60W, 120 Vac / 24 Vdc rectifier. Resistive snubbers ($R_s = 1e6 \Omega$) are used across diodes.

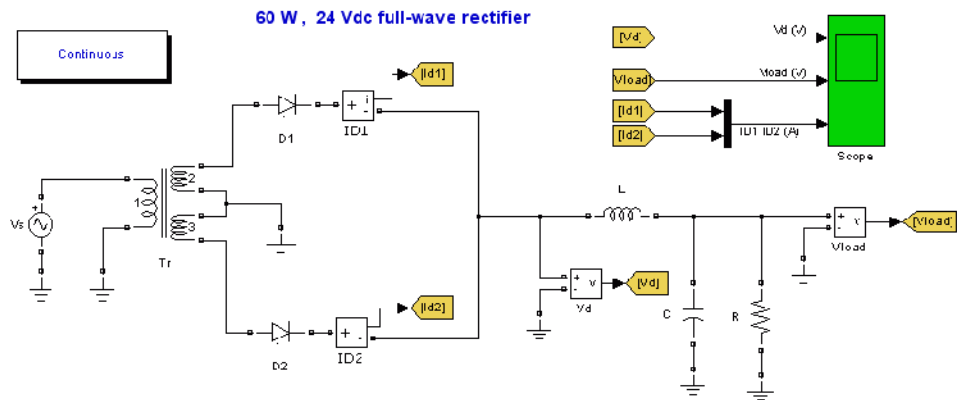

- 2 Open the **Configure parameters** section of the Powergui block. Clear the **Enable use of ideal switching devices** parameter.
- 3 Set the **Simulation type** parameter of the Powergui block to **Continuous**, and define the following solver:

Type	Variable-step
Solver	ode23tb
Relative tolerance	1e-6
Solver reset method	Fast
Stop time	0.1
Other parameters	auto

- 4 Start the simulation. You see the following waveforms.

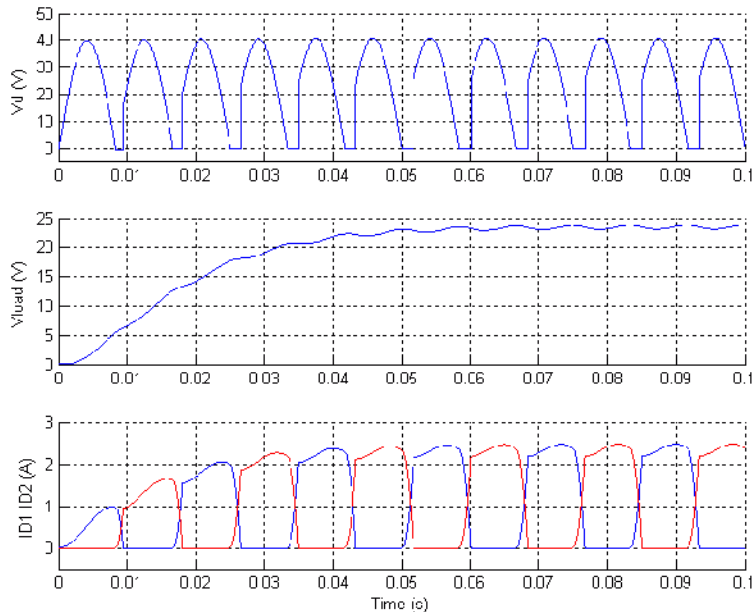

- 5 Increase the snubber resistance by specifying $R_s = 1e8 \Omega$ in the two diode blocks and simulate again. When using such high snubber resistances, simulation results become incorrect. To get correct results, you must increase the solver accuracy by either limiting the **Max step size** to $1e-7$, or setting the **Solver Reset Method** to **Robust**.

When you try to get rid of snubbers in large circuits containing many power electronic devices, reduction of maximum step size or solver tolerances might result in an unacceptable simulation time. In some circumstances, the solver might even fail to find a solution..

- 6 Open the block parameters of the Powergui block and select **Enable use of ideal switching devices** parameter. Select **Disable snubbers in switching devices** parameter. To simulate perfectly ideal switches, you can also disable the diode resistances (R_{on}) and the forward voltages (V_f).
- 7 Make sure that your solver parameters are as shown in 3. Simulate and observe that waveforms are correct.
- 8 Eliminating the snubbers has reduced the circuit stiffness. You can now use `ode45` solver instead of `ode23tb`.

Simulating Discretized Electrical Systems

In this section...

“Introduction” on page 3-14

“Discretizing Switches and Power Electronics” on page 3-15

“Discretizing Electrical Machines” on page 3-16

Introduction

You implement discretization by selecting **Discretize electrical model** in the **Powergui** block dialog box. The sample time is specified in the block dialog box. The electrical system is discretized using one of these methods: Tustin (equivalent to a fixed-step trapezoidal method), Backward Euler, or Tustin/Backward Euler (TBE).

The TBE discretization method combines the accuracy of the Tustin method and the numerical oscillation damping property of the Backward-Euler method. Tustin and Backward Euler methods are still available for compatibility. TBE method allows you to simulate power electronic circuits with virtually no snubber, using purely resistive snubbers with a very large resistance value resulting in negligible leakage currents.

For the three-phase asynchronous and synchronous machines, you select the discretization method on the Advanced tab of the block dialog box. Use the trapezoidal method (either iterative or noniterative). For other machines, use the Forward Euler method to avoid algebraic loops.

The precision of the simulation is controlled by the time step that you choose for the discretization. If you use too large a sample time, the precision might not be sufficient. The only way to know if it is acceptable is to repeat the simulation with different sample times or to compare it with a continuous method and to find a compromise for the largest acceptable sample time. Usually sample times of 20 μs to 50 μs give good results for simulation of switching transients on 50 Hz or 60 Hz power systems or on systems using line-commutated power electronic devices such as diodes and thyristors. However, for systems using forced-commutated power electronic switches, you must reduce the time step. These devices, the insulated-gate-bipolar transistor (IGBT), the field-effect transistor (FET), and the gate-turnoff thyristor (GTO) are usually operating at high switching frequencies. For example, simulating a pulse-width-modulated (PWM) inverter operating at 5 kHz requires a maximum time step of 1 μs .

Even if you discretize your electric circuit, you can still use a continuous control system. However, the simulation speed is improved by use of a discrete control system.

Discretizing Switches and Power Electronics

Switches and power electronic devices are nonlinear elements which are represented by a purely resistive element having a low R_{on} resistance when the switch is closed and an infinite resistance when the switch is opened. Each time a switch status is changed during the simulation, the discrete state-space model of the linear part of the circuit is re-evaluated to take into account the change in circuit topology. Due to the way the state-space model is computed, switches cannot be connected in series with inductive circuits. For most applications, snubber circuits have to be connected across power electronic devices.

For forced-commutated devices, the snubber circuit can be made negligible by using purely resistive snubbers with a high resistance. However, for circuits containing naturally commutated devices such as diodes and thyristors, because a fixed simulation time step is used, when the device is blocked, the current zero-crossing is not detected accurately.

You select the discretization method in the **Configure parameters** menu of the Powergui block. The default discretization method is the Tustin/Backward Euler (TBE) method. This method combines the Tustin method and the Backward Euler method. The TBE method allows you to simulate snubberless diode and thyristor converters. It avoids numerical oscillations seen with the Tustin method and provides better accuracy than the Backward Euler method.

Comparison of Tustin, Backward Euler, and Tustin/Backward Euler Methods

Open the Comparison of Tustin, Backward Euler and Tustin/Backward Euler (TBE) with a Continuous Reference Model example model. This example uses a three-phase, half-wave diode rectifier model to compare the accuracy and stability of three discretization methods: Tustin, Backward Euler, and Tustin/Backward Euler (TBE).

Four identical models of the diode rectifier are simulated in four separate subsystems. Each subsystem contains its own Powergui block specifying the simulation type (Continuous or Discrete), the solver type (discretization method), and the sample time. The Scope block allows you to compare the load voltage (V_d) and the load current (I_d) obtained with each discretization method. Reference waveforms are computed by the continuous solver.

The Continuous model uses the Ideal switching devices technique and no diode snubbers (snubbers disabled). The three discrete models use 1 M Ω resistive snubbers, resulting in negligible parasitic currents. The three discrete models can therefore also be considered snubberless. A 20 μ s sample time is used for the three discrete models.

Run the simulation and observe waveforms on the Vd and Id Scopes. The Tustin method produces numerical oscillations on load voltage. The Backward Euler does not produce numerical oscillations but it provides too much damping, especially on the Id current. The TBE method eliminates the numerical oscillations while preserving accuracy.

Discretizing Electrical Machines

Electrical machines are nonlinear elements simulated as current sources. These elements cannot be connected to an inductive network unless a parasitic resistive or capacitive element is connected at machine terminals.

When using electrical machines in discrete systems, you might have to increase these parasitic resistive load to avoid numerical oscillations. The amount of parasitic load depends on the sample time and on the integration method used to discretize the electrical machine.

For the Synchronous Machine model and the Asynchronous Machine model, you can select either a Forward Euler or a Trapezoidal discretization method. All other machine models use the Forward Euler discretization method.

For the Synchronous Machine and the Asynchronous Machine, you select the machine discretization method in the Advanced Tab of the block menu. When using an implicit solver, such as the Trapezoidal iterative model, you obtain the highest accuracy. Using this model produces an algebraic loop, which forces the Simulink solver to iterate, resulting in a higher accuracy. However, this higher accuracy is at the expense of a slower simulation speed.

The Trapezoidal iterative model allows you to simulate machines with negligible parasitic loads while preserving numerical stability. However, if your model contains many machines and nonlinear elements such as power electronic devices, the Simulink solver might fail to solve the algebraic loop. In such a case you must use a noniterative discretization method such as the Forward Euler model or the Trapezoidal noniterative model (Trapezoidal model in which the algebraic loop is broken by introducing a Unit Delay).

Using noniterative solvers requires larger parasitic loads or a smaller sample time. The minimum resistive load is proportional to the sample time. Remember that with a 25 μs time step on a 60 Hz system, the minimum load is approximately 2.5% of the machine nominal power. For example, a 200 MVA synchronous machine in a power system discretized with a 50 μs sample time requires approximately 5% of resistive load or 10 MW. If the sample time is reduced to 20 μs , a resistive load of 4 MW is sufficient.

Example of discrete model using SM and ASM blocks

The following example illustrates impact of the machine discretization methods and amount of parallel load on model stability.

- 1 Open the Emergency Diesel-Generator and Asynchronous Motor example model. This model contains a synchronous machine (SM) and an asynchronous machine (ASM) connected at the same bus in parallel with a 1 MW load.
- 2 In the Powergui menu, select **Configure parameters**, select **Simulation type = discrete**, and specify a **sample time** of $T_s = 50 \mu\text{s}$.
- 3 Use the Load Flow tool to initialize the machine models (click the **Compute** and **Apply** buttons in the Powergui Load Flow window).
- 4 Start the simulation and observe that the model starts in a steady-state.

In this model, the default discretization method specified in the Advanced Tab of the synchronous machine block and of the asynchronous machine block is Trapezoidal noniterative. The model is stable because a relative large load of 1 MW is connected at the machine terminals. This load represents 32% of the SM nominal power and 60% of the ASM nominal power.

The following figure compares simulation results of the two noniterative discrete models (Forward Euler and Trapezoidal noniterative) with the reference waveforms obtained from the continuous model. In the figure, three sets of waveforms are shown for phase A voltage (trace 1), phase A current of ASM (trace 2), phase A current of SM (trace 3), and ASM and SM speeds (trace 4).

- Continuous model (blue)
- Discrete model using ASM and SM Forward Euler models (red)
- Discrete model using ASM and SM Trapezoidal noniterative models (green)

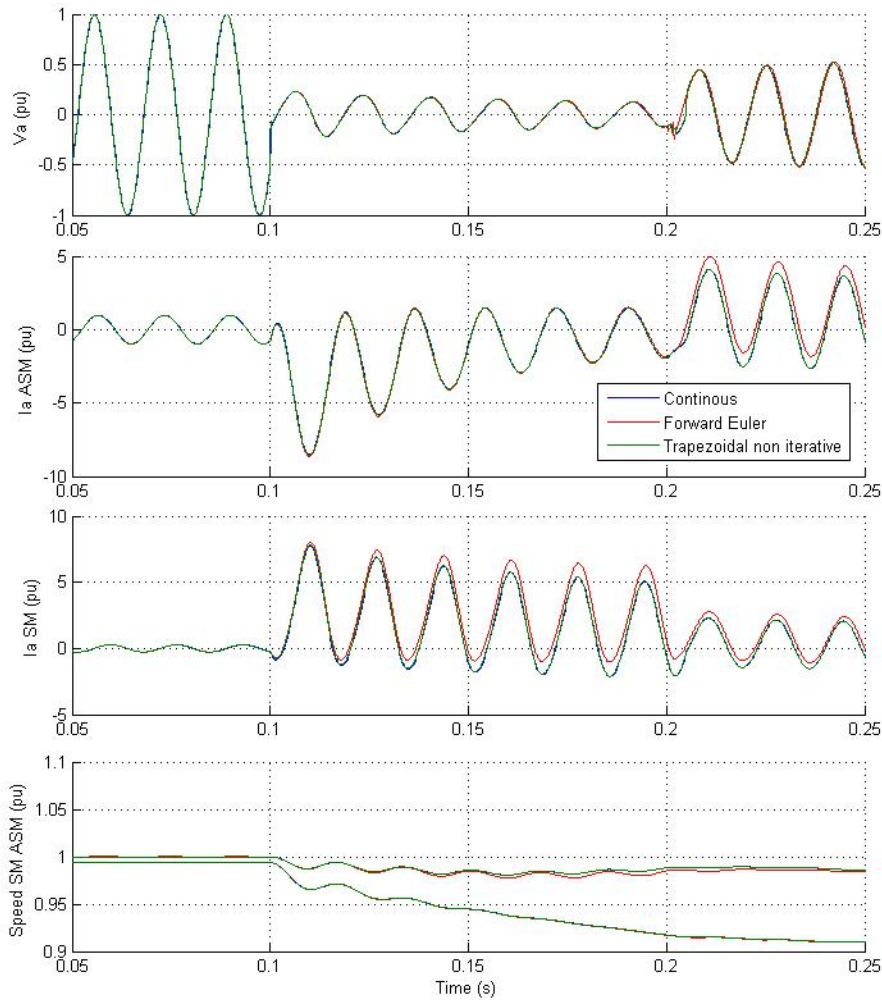

The Trapezoidal noniterative model provides better accuracy than the Forward Euler model. The simulation error is particularly visible on trace 2 and on trace 3 showing that the Forward Euler model fails to preserve the DC component of the ASM and SM currents.

Now simulate this discrete model with virtually no load connected at machine terminals. You may try decreasing the 1 MW load to say 1 kW (representing respectively 0.032% and 0.06% of SM and ASM machine nominal powers).

Change the resistive load from 1MW to 1 kW and start simulation. Notice the numerical oscillations, because the 1 kW load is too small to guarantee stability of the Forward Euler machine models.

If you vary the load by steps of 50 kW, you discover that the minimum load required to obtain a stable model is 300 kW for both the Forward Euler and Trapezoidal noniterative models, corresponding to 6.2% of the total machine nominal power (4.80 MVA = 3.125 MVA for ASM + 1.678 MVA for SM).

The only way to simulate this discrete model with a 1 kW load is to use the Trapezoidal iterative method for both machines. Simulink now displays a warning signalling an algebraic loop. Simulation results are exact and are as accurate as the Continuous model. The drawback is a much slower simulation speed.

Increasing Simulation Speed

In this section...
“Ways to Increase Simulation Speed” on page 3-20
“Using Accelerator Mode and Simulink Coder” on page 3-20

Ways to Increase Simulation Speed

Once you have selected the proper method (continuous, discrete, or phasor), solver type, and parameters, there are additional steps you can take to optimize your simulation speed.

- Discretizing your electric circuit and your control system. You can even use a larger sample time for the control system, provided that it is a multiple of the smallest sample time.
- Simulating large systems or complex power electronic converters can be time consuming. If you have to repeat several simulations from a particular operating point, you can save time by specifying a vector of initial states in the **Simulation > Configuration Parameters > Workspace IO** dialog box. This vector of initial conditions must have been saved from a previous simulation run.
- Reducing the number of open scopes and the number of points saved in the scope also helps in reducing the simulation time.
- Using the Simulink Accelerator mode. The performance gain obtained with the Accelerator varies with the size and complexity of your model. Typically you can expect performance improvements by factors of two to 10.

Using Accelerator Mode and Simulink Coder

The Accelerator mode speeds up the execution of Simulink models by replacing the interpreted M code running beneath the Simulink blocks with compiled code as your model executes. The Accelerator mode uses portions of Simulink Coder to generate this code on the fly. Although the Accelerator mode uses this technology, Simulink Coder is not required to run it. Also, if you do not have your own C compiler installed, you can use the LCC compiler provided with your MATLAB installation.

To activate the Accelerator mode, select **Simulation > Mode > Accelerator** from the toolbar of your model window. Alternatively, you can select **Accelerator** from the pull-down menu in the model window toolbar.

The following table shows typical performance gains obtained with discretization and Accelerator mode applied to the following two examples: a DC drive using a chopper and the AC-DC converter using a three-phase, three-level voltage-sourced converter. Two versions of the DC drive model are provided as examples shipped with the product: a continuous version, `power_dcdrive`, and a discrete version, `power_dcdrive_disc`. The AC-DC converter is available as the `power_3levelVSC` example.

Simulation Method	Simulation Time in Seconds*	
	DC drive	AC-DC converter
	(Stop time = 2 s)	(Stop time = 0.2 s)
Continuous: ode23tb default parameters	12	—
Discrete	9.0 (Ts = 10 μs)	14.5 (Ts = 5 μs)
Discrete + Accelerator	5.2 (Ts = 10 μs)	3.3 (Ts = 5 μs)

* Simulation times obtained on a Pentium IV 2.6 GHz processor, with 512 MB of RAM

The table shows how discretizing your circuit speeds up the simulation by a factor of 1.33 for the DC drive. Using the Accelerator mode, an additional factor of 1.7 performance gain is obtained. For the AC-DC converter, the Accelerator mode provides a gain of 4.4 times. For complex power electronic converter models, the Accelerator mode provides performance gains up to factors of 15.

To take full advantage of the performance enhancements made possible by converting your models to code, you must use Simulink Coder software to generate standalone C code. You can then compile and run this code and, with Simulink Real-Time™ software, also run it on a target PC operating the Simulink Real-Time real-time kernel.

Creating Your Own Library of Models

SimPowerSystems software provides a variety of basic building blocks to build more complex electric blocks. Using the masking feature of the Simulink software, you can assemble several elementary blocks from the SimPowerSystems Specialized Technology library into a subsystem, build your own parameter dialog box, create the block icon that you want, and place this new block in your personal library.

“Building and Customizing SimPowerSystems Models” on page 2-49 describes how to build a nonlinear model using a **Voltage Measurement** block and a **Controlled Current Source** block. The proposed examples (a nonlinear inductance and a nonlinear resistance) are relatively simple. Using the same principle, you can develop much more complex models using several controlled current sources, or even controlled voltage sources.

Change Circuit Parameters

In this section...

“Introduction” on page 3-23

“Example of MATLAB Script Performing a Parametric Study” on page 3-23

Introduction

Each time that you change a parameter of the SimPowerSystems Specialized Technology library blocks, you have to restart the simulation to evaluate the state-space model and update the parameters of the nonlinear models. However, you can change any source parameter (Magnitude, Frequency, or Phase) during the simulation. The modification takes place as soon as you apply the modification or close the source block menu.

For the Simulink blocks, all the SimPowerSystems Specialized Technology library block parameters that you specify in the dialog box can contain MATLAB expressions using symbolic variable names. Before running the simulation, you must assign a value to each of these variables in your MATLAB workspace. This assignment allows you to perform parametric studies by changing the parameter values in a MATLAB script.

Example of MATLAB Script Performing a Parametric Study

Suppose that you want to perform a parametric study in a circuit named `my_circuit` to find the impact of varying an inductance on switching transients. You want to find the highest overvoltage and the inductance value for which it occurred.

The inductance value of one of the blocks contains variable `L1`, which you must define in your workspace. `L1` is varied in 10 steps from 10 mH to 100 mH and the values to be tested are saved in a vector, `L1_vec`. The voltage waveform to be analyzed is stored in a ToWorkspace block in array format with `V1` variable name.

You can write a MATLAB script that loops on the 10 inductance values and displays the worst case scenario.

```
L1_vec= (10:10:100)*1e-3; % 10 inductances values 10/100 mH
V1_max=0;
for i=1:10
    L1=L1_vec(i);
    fprintf('Test No %d L1= %g H\n', i, L1);
    sim('my_circuit'); % performs simulation
```

```
% memorize worst case
if max(abs(V1))>V1_max,
    imax=i;
    V1_max=max(abs(V1));
end
end

fprintf('Maximum overvoltage= %g V occurred for L1=%g H\n', V1_max, L1_vec(imax));
```

Systems with Electric Drives

- “Electric Drives Library” on page 4-2
- “Simulate a DC Motor Drive” on page 4-11
- “Simulate an AC Motor Drive” on page 4-33
- “Mechanical Models” on page 4-61
- “Mechanical Coupling of Two Motor Drives” on page 4-63
- “Winding Machine” on page 4-70
- “Robot Axis Control Using Brushless DC Motor Drive” on page 4-78
- “Building Your Own Drive” on page 4-89
- “Retune the Drive Parameters” on page 4-100
- “Modify a Drive Block” on page 4-115
- “Multi-Level Modeling for Rapid Prototyping” on page 4-122

Electric Drives Library

In this section...

“Electric Drives Library Overview” on page 4-2

“What Is an Electric Drive?” on page 4-3

“Three Main Components of an Electric Drive” on page 4-3

“Multiquadrant Operation” on page 4-5

“Average-Value Models” on page 4-6

“User Interface” on page 4-7

“General Layout of the Library's GUIs” on page 4-7

“Features of the GUIs” on page 4-8

Electric Drives Library Overview

The Electric Drives library is designed for engineers from many disciplines who want to incorporate easily and accurately electric drives in the simulation of their systems. A specialized interface presents the parameters of the selected drive in a system-look topology, thereby simplifying the adjustments users may want to bring to the default values. Then they can seamlessly use any other toolboxes or blocksets to analyze the time or frequency behavior of the electric drive interacting with its system. The library is most helpful when a powerful drive has to be carefully maneuvered without ignoring the operating limits of the load on one side and of the power source on the other side. A good example is the electric drive system of a hybrid car that can switch in milliseconds from driving the wheels to recharging the batteries when the brakes are engaged.

Engineers and scientists can work readily with the library. The library has seven typical direct current (DC) drives used in industries and transportation systems, eight alternating current (AC) drives providing more efficient and versatile motors from traction to positioning devices, and shaft and speed reducer models useful for connecting to the motor a model of load made of Simulink blocks. An added value of the library is parameters that assure the validity of the motor, the power converters, and the control system. When designing the library, particular attention was devoted to the motor models by comparing the models' behavior to the published data of the major manufacturers. Numerous examples or case studies of typical drives are supplied with the library. Hopefully, typical user systems are similar to these analyzed systems, thereby saving time in building the practical system and supplying a known reference point in the analysis.

To access the Electric Drives library, type `simpowersystems_ST`, at the MATLAB command prompt to open the SimPowerSystems Specialized Technology main library, then double-click the **Electric Drives** icon. You can also access the Electric Drives library through the Library Browser, under **Simscape > SimPowerSystems > Specialized Technology**.

What Is an Electric Drive?

An electric drive is a system that performs the conversion of electric energy into mechanical energy at adjustable speeds. This is the reason why an electric drive is also called adjustable speed drive (ASD). Moreover, the electric drive, as we will see later, always contains a current (or torque) regulation in order to provide safe current control for the motor. Therefore, the electric drive torque/speed is able to match in steady state the torque/speed characteristics of any mechanical load. This motor to mechanical load match means better energy efficiency and leads to lower energy costs. In addition, during the transient period of acceleration and deceleration, the electric drive provides fast dynamics and allows soft starts and stops, for instance.

A growing number of applications require that the torque and speed must vary to match the mechanical load. Electric transportation means, elevators, computer disk drives, machine tools, and robots are examples of high-performance applications where the desired motion versus time profile must be tracked very precisely. Pumps, fans, conveyers, and HVAC (heat, ventilation, air conditioners) are examples of moderate performance applications where variable-speed operation means energy savings.

Three Main Components of an Electric Drive

An electric drive has three main components:

- The electric motor
- The power electronic converter
- The drive controller

The following figure shows the basic topology of an electric drive. Beside the three main components, the figure shows an electric power source, a mechanical load, electric and motion sensors, and a user interface.

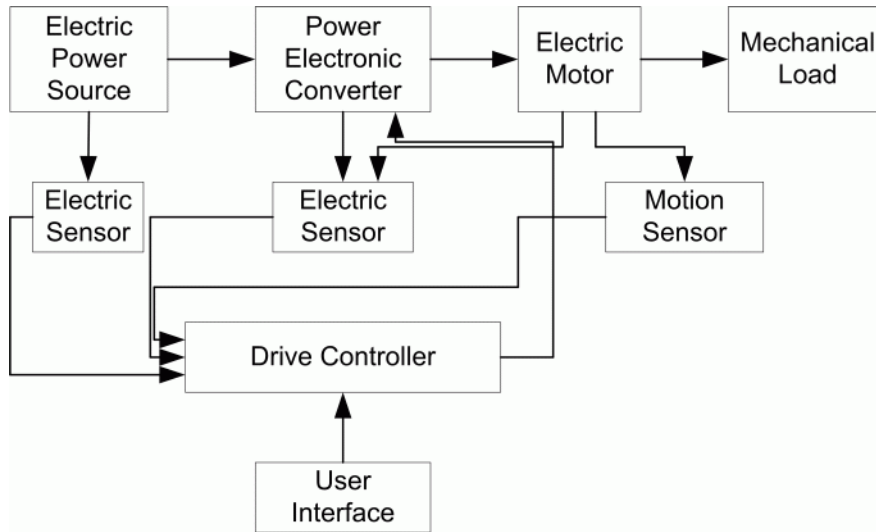

Electric Drive Basic Topology

The motor used in an electric drive is either a direct current (DC) motor or an alternating current (AC) motor. The type of motor used defines the electric drive's classification into DC motor drives and AC motor drives. The ease of producing a variable DC voltage source for a wide range of speed control made the DC motor drive the favorite electric drive up to the 1960s. Then the advances of power electronics combined with the remarkable evolution of microprocessor-based controls paved the way to the AC motor drive's expansion. In the 1990s, the AC motor drives took over the high-performance variable-speed applications.

The power electronic converter produces variable AC voltage and frequency from the electric power source. There are many types of converters depending on the type of electric drive. The DC motor drives are based on phase-controlled rectifiers (AC-DC converters) or on choppers (DC-DC converters), while the AC motor drives use inverters (DC-AC converters) or cyclo converters (AC-AC converters). The basic component of all the power electronic converters is the electronic switch, which is either semicontrollable (controllable on-state), as in the case of the thyristor, or fully controllable (controllable on-state and off-state), as in the cases of the IGBT (insulated gate bipolar transistor) and the GTO (gate turn off thyristor) blocks. The controllable feature of the electronic switch is what allows the converter to produce the variable AC voltage and frequency.

The purpose of the drive controller is essentially to convert the desired drive torque/speed profile into triggering pulses for the electronic power converter, taking into account various drive variables (currents, speed, etc.) fed back by the sensors. To accomplish this, the controller is based first on a current (or torque) regulator. The current regulator is mandatory because, as mentioned previously, it protects the motor by precisely controlling the motor currents. The set point (SP) of this regulator can be supplied externally if the drive is in torque regulation mode, or internally by a speed regulator if the drive is in speed regulation mode. In the Electric Drives library, the speed regulator is in series with the current regulator and is based on a PI controller that has three important features. First, the SP rate of change is limited so that the desired speed ramps gradually to the SP, in order to avoid sudden step changes. Second, the speed regulator output that is the SP for the current regulator is limited by maximum and minimum ceilings. Finally, the integral term is also limited in order to avoid wind-up. The following figure shows a block diagram of a PI controller-based speed controller.

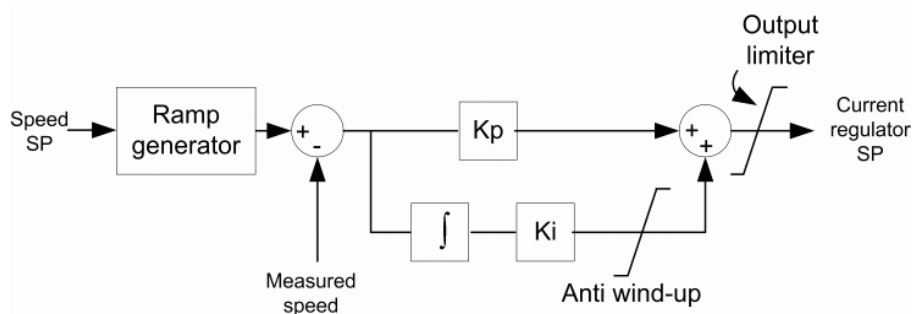

Block Diagram of the PI Controller-Based Speed Regulator

Multiquadrant Operation

For each electric drive application, the mechanical load to be driven has a specific set of requirements. The torque/speed possibilities of the electric drive can be represented as a speed versus torque graph consisting of four quadrants. In the first quadrant, the electric torque and the speed signs are both positive, indicating forward motoring since the electric torque is in the direction of motion. In the second quadrant, the electric torque sign is negative and the speed sign is positive, indicating forward braking since the electric torque is opposite to the direction of motion. In the third quadrant, the electric torque and speed signs are both negative, indicating reverse motoring. In the fourth quadrant, the electric torque sign is positive and the speed is negative, indicating reverse

braking. The drive braking is handled either by a braking chopper (dynamic braking) or by bidirectional power flow (regenerative braking).

The following figure illustrates the four-quadrants operating region of an electric drive. Each quadrant has a constant torque region from 0 to +/- nominal speed ω_b and a region where the torque decreases inversely with the speed from ω_b to the maximum speed ω_{max} . This second region is a constant power region and is obtained by decreasing the motor magnetic flux.

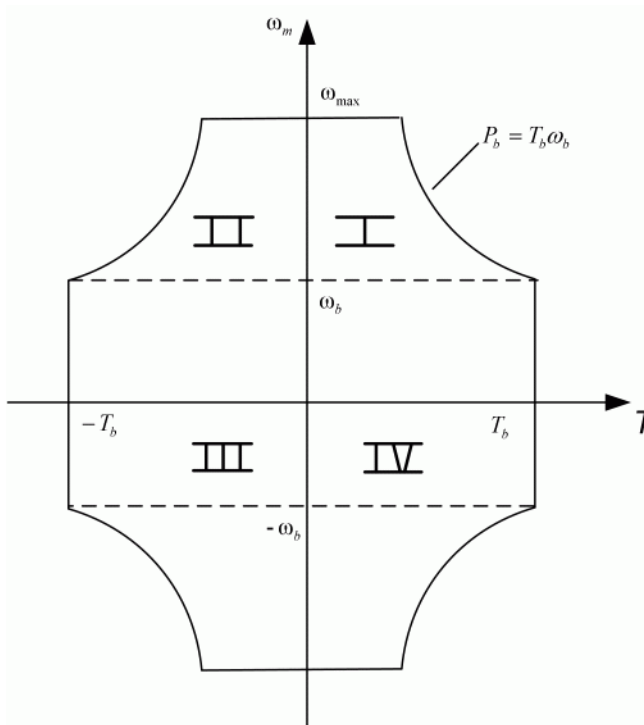

Four-Quadrant Operation of an Electric Drive

Average-Value Models

The AC and DC library allows two levels of simulation, detailed simulations or average-value simulations. The detailed simulations use the Universal Bridge block to represent the detailed behavior of rectifier and inverter controlled drives. This simulation level

requires small simulation time steps to achieve correct representation of the high frequency electrical signal components of the drives.

The average-value simulations use average-value models of the power converters. When simulating in average-value mode, the electrical input and output currents and voltages of the power converters driving the electrical motors represent the average values of the real-life currents and voltages. By doing so, the high frequency components are not represented and the simulations can use much bigger time steps. Each power converter average-value model is described in the detailed documentation associated with each DC or AC model type. The time step used in a drive at average-value level can usually be increased up to the smallest controller sampling time used in a model. For example, if a drive uses a 20 μs time step for the current loop and a 100 μs time step for the speed loop, then the simulation time step in average-value mode can be increased up to 20 μs . Simulation time step guidelines are given in the detailed documentation of each model.

Switching between the detailed simulation level and the average-value simulation level can easily be done via the GUI associated with each model, as explained in “Selecting the Detailed or the Average-Value Model Detail Level” on page 4-9.

User Interface

The drive models supplied in the library are relatively complex and involve a large number of parameters. The Electric Drives library provides GUIs for all models. The GUIs offer all the functionality you would expect from existing Simulink masks, plus some additional features, as outlined below.

General Layout of the Library's GUIs

The general layout of the GUIs is identical to the layout of Simulink masks. A short description of the model appears at the top, parameters are entered in the middle portion, and buttons are placed at the bottom.

The parameters section is divided in three tabs at the top level, for all drive models supplied in the library. You enter parameters related to the electric machine, converters and DC bus, and controller in the first, second and third tabs, respectively. The following figure illustrates the **Self-Controlled Synchronous Motor Drive** GUI with the **Controller** tab active.

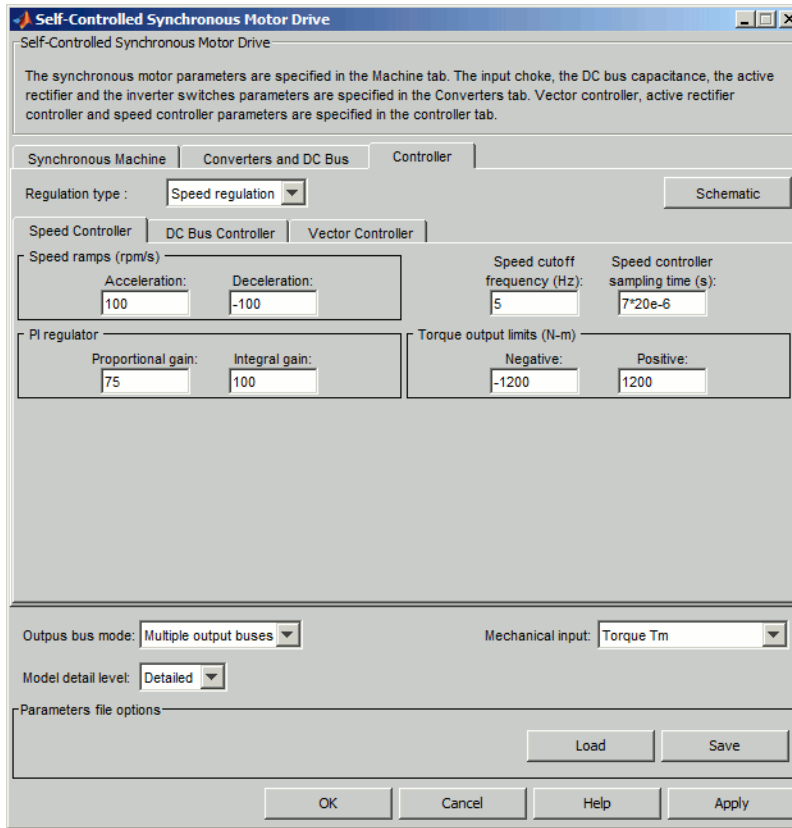

Features of the GUIs

The GUIs offer the same functionality as Simulink masks. You can enter as parameters numerical values, valid MATLAB expressions, and MATLAB variables. An important difference between these GUIs and Simulink masks is that you can only enter a single value in each input field (e.g., vectors and arrays are not allowed).

The other differences (with respect to Simulink masks) are outlined below.

Parameter Validation

The GUIs are designed to signal invalid parameters as early as possible. Hence, if you enter an invalid constant (for example 1.2.3 or --2) in a drive model's GUI, an error is

flagged as soon as you move away from the invalid parameter (for instance if you try to change another parameter in the GUI). Variables are treated slightly differently. If you enter a variable name that has not yet been defined in the MATLAB workspace, parameter validation is deferred until you start the simulation of the diagram that contains the model.

Saving Parameters in a File

At the bottom of Simulink masks, the GUIs include **Load** and **Save** buttons. The **Save** button enables you to save in a file the complete set of parameters of the GUI. The format of the file is the standard MATLAB binary (.MAT) format. The **Load** button enables you to recover a previously saved set of parameters for a given drive type (e.g., AC1, DC2, etc.). When you load a set of parameters, the drive type of the saved parameters is compared to the drive type of the model that you are loading the parameters into, to ensure that you are loading parameters compatible with the model.

When you use the **Load** button, the dialog box that opens points to the directory in your MATLAB installation that contains the standard sets of parameters supplied for all the drives in the library.

However, when you use the **Save** button, the dialog box that opens points to the current working directory in the MATLAB workspace.

Displaying the Controller Schematic

In all drive models, in the top right corner of the **Controller** tab, there is a **Schematic** button. When you click this button, the control schematic of the drive model will appear in a new window.

Selecting the Output Bus Mode

You can select how the various signals output from the block by using the **Output bus mode** menu located in the lower part of the GUI.

Selecting the Detailed or the Average-Value Model Detail Level

You can select the detailed or the average-value simulation level by using the **Model detail level** menu located in the lower part of the GUI. Remember to modify the simulation time step with respect to the model detail level used.

Selecting the Mechanical Input

You can select either the load torque or the motor speed as mechanical input. Use the **Mechanical input** menu located in the lower part of the GUI. Note that if you select

the motor speed as mechanical input, the internal mechanical system is not used and the inertia and viscous friction parameters are not displayed. You have to include these parameters in the external mechanical system.

Simulate a DC Motor Drive

In this section...

“Introduction” on page 4-11

“Regenerative Braking” on page 4-12

“Example: Thyristor Converter-Based DC Motor Drive” on page 4-12

Introduction

In this section, you will learn how to use the DC drive models of the Electric Drives library. First, we will specify the types of motor, converters, and controllers used in the seven DC drive models of the library, designated DC1 to DC7. These seven models are based on the DC brush motor in the Electric Drives library. As in any electric motor, the DC brush motor has two main parts, the stator (fixed) part and the rotor (movable) part. The DC brush motor also has two types of windings, the excitation or field winding and the armature winding. As its name implies, the field winding is used to produce a magnetic excitation field in the motor whereas the armature coils carry the induced motor current. Since the time constant (L/R) of the armature circuit is much smaller than that of the field winding, controlling speed by changing armature voltage is quicker than changing the field voltage. Therefore the excitation field is fed from a constant DC voltage source while the armature windings are fed by a variable DC source. The latter source is produced by a phase-controlled thyristor converter for the DC1 to DC4 models and by a transistor chopper for the DC5, DC6, and DC7 models. The thyristor converter is fed by a single-phase AC source in the cases of DC1 and DC2 and by a three-phase AC source in the cases of DC3 and DC4. Finally, the seven DC models can work in various sets of quadrants. All these possibilities are summarized in the following table.

DC Models

Model	Type of Converter	Operation Quadrants
DC1	Single-phase thyristor converter	I-II
DC2	Single-phase thyristor converter	I-II-III-IV
DC3	Three-phase thyristor converter	I-II
DC4	Three-phase thyristor converter	I-II-III-IV
DC5	Chopper	I
DC6	Chopper	I-II
DC7	Chopper	I-II-III-IV

Regenerative Braking

Operation in quadrants II and IV corresponds to forward and reverse braking, respectively. For the DC models of the Electric Drives library, this braking is regenerative, meaning that the kinetic energy of the motor-load system is converted to electric energy and returned to the power source. This bidirectional power flow is obtained by inverting the motor's connections when the current becomes null (DC1 and DC3) or by the use of a second converter (DC2 and DC4). Both methods allow inverting the motor current in order to create an electric torque opposite to the direction of motion. The chopper-fed DC drive models (DC5, DC6, DC7) produce regenerative braking in similar fashions.

Example: Thyristor Converter-Based DC Motor Drive

In this example, you will build and simulate the simple thyristor converter-based DC motor drive shown in Thyristor Converter-Based DC Motor Drive Example Circuit.

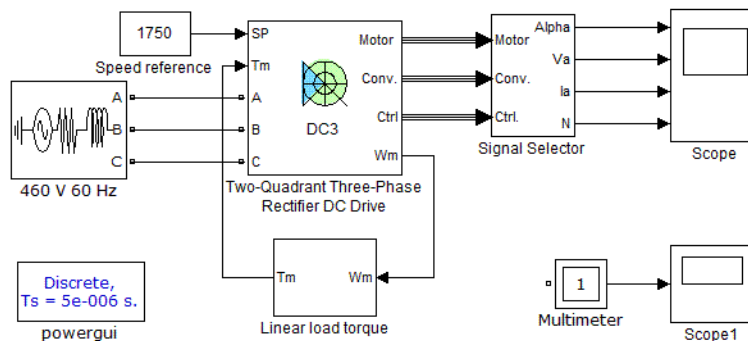

Thyristor Converter-Based DC Motor Drive Example Circuit

This step-by-step example illustrates the use of the DC3 model with a 200 hp DC motor parameter set during speed regulation. The DC3 block models a two-quadrant three-phase thyristor converter drive. During this example, the motor will be connected to a load and driven to its 1750 rpm nominal speed.

In this tutorial, you learn about

- “Getting the DC3 Model from the Drives Library” on page 4-13
- “Connecting the DC3 Model to a Voltage Source” on page 4-13
- “Connecting the DC3 Model to a Mechanical Load” on page 4-16

- “Defining the Set Point” on page 4-17
- “Visualizing Internal Signals” on page 4-17
- “Setting the Fixed-Step Simulation Environment” on page 4-21
- “Setting the High Power Drive Parameter Set” on page 4-22
- “Setting the Motor Inertia Value” on page 4-23
- “Setting the DC3 Controller Parameters and Simulation Results” on page 4-23

Getting the DC3 Model from the Drives Library

- 1 Open a new window and save it as `DC_example`.
- 2 Open the SimPowerSystems Electric Drives library. You can open the library by typing `electricdrive.lib` in the MATLAB Command Window or by using the Simulink Library Browser. The DC3 model is located inside the DC Drives library. Copy the DC3 block and drop it in the `DC_example` window.

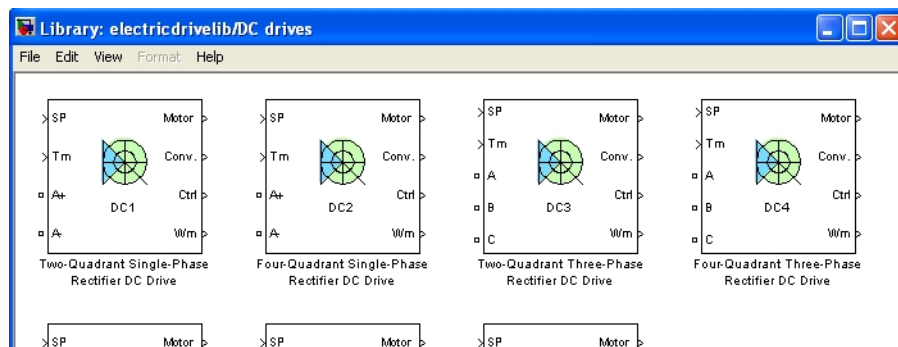

DC3 Model Inside the Electric Drives Library

Connecting the DC3 Model to a Voltage Source

All models of the library have three types of inputs: the electrical power inputs, the speed or torque set point input (SP), and the mechanical torque input (Tm). Because the DC3 model is a three-phase drive, it presents three electrical inputs: A, B, and C. In order for the DC3 model to work, you must now connect those inputs to a proper voltage source:

- 1 Open the Electrical Sources library and copy the 3-Phase Source block into your circuit. Connect the voltage source outputs A, B, and C to the DC3 A, B, and C inputs, respectively.

In this example, you are driving a 200 hp DC motor of 500 V nominal armature voltage. The mean output voltage \hat{V}_{out} of a three-phase thyristor rectifier bridge is given by

$$\hat{V}_{out} = \frac{3\sqrt{2} \cdot V_{l,rms}}{\pi} \cdot \cos \alpha$$

where $V_{l,rms}$ is the phase-to-phase rms voltage value of the three-phase voltage source and α is the firing angle value of the thyristors. For better voltage control, a lower firing angle limit is usually imposed, and the maximum mean output voltage available from the rectifier bridge is thus given by

$$\hat{V}_{out,max} = \frac{3\sqrt{2} \cdot V_{l,rms}}{\pi} \cdot \cos \alpha_{min}$$

where α_{min} is the lower firing angle limit. In our case, the lower firing angle limit used in the DC3 model is 20 degrees. With such an angle value and in order to have a maximum mean output voltage value of 500 V to drive the 200 hp motor to its nominal speed, the needed phase-to-phase rms voltage value given by the preceding equation is 370 V. Assuming the drive is connected to an American electrical network, the closest standard voltage value is 460 V.

- 2 Set the AC source phase-to-phase rms voltage value to 460 V and the frequency to 60 Hz. Name the AC source 460 V 60 Hz.

Note that the voltage source amplitude and frequency values needed for each drive model of the Electric Drives library can be found in the reference notes. The nominal values of the corresponding motors are also included. DC3, 200 HP Drive Specifications contains the values corresponding to the DC3 200 hp model.

DC3, 200 HP Drive Specifications

Drive Input Voltage

Amplitude	460 V
Frequency	60 Hz

Motor Nominal Values

Power	200 hp
Speed	1750 rpm
Voltage	500 V

In order to represent a real-life three-phase source, you must specify correct source resistance R and inductance L values. To determine these, one usually uses the short-circuit power value P_{sc} and a given X/R ratio (where $X = L \cdot \omega$, ω being the angular frequency of the voltage source). As a rule of thumb, the short-circuit power absorbed by the source impedance is supposed to be at least 20 times bigger than the nominal power of the drive, and the X/R ratio is usually close to 10 for industrial plants.

The value of the source impedance Z is obtained by

$$Z = \frac{V^2}{P_{sc}}$$

where V is the phase-to-phase rms voltage value of the voltage source. For a high X/R ratio r , the source resistance R is approximately equal to

$$R = \frac{Z}{r}$$

and the source inductance L to

$$L = \frac{Z}{\omega}$$

In this example, the phase-to-phase rms voltage is worth 460 V and the source frequency is 60 Hz. If we assume a short-circuit power of 25 times the nominal drive power, we find a source impedance of 0.056 Ω . For an X/R ratio of 10, using Equation 4-1 and Equation 4-2, we find a resistance value of 0.0056 Ω and an inductance value of 0.15 mH.

- 3 Clear the **Specify impedance using short-circuit level** check box, and set the AC source resistance value to 0.0056 Ω and the inductance to 0.15 mH.

Connecting the DC3 Model to a Mechanical Load

The T_m input represents the load torque applied to the shaft of the DC motor. If the values of the load torque and the speed have opposite signs, the acceleration torque will be the sum of the electromagnetic and load torques. Many load torques are proportional to the speed of the driven load such as represented by the equation

$$T_{mec} = K \cdot \omega_m = K' \cdot N_m$$

where ω_m is the speed in rad/s and N the speed in rpm. You will now build such a load.

To compute this type of mechanical load torque, the speed of the DC motor is needed. This one can be obtained by using the outputs of the DC3 model. All drive models of the Electric Drives library have four output vectors: Motor, Conv., Ctrl, and Wm. The Motor vector contains all motor-related variables, the Conv. vector contains all converter voltage and current values, the Ctrl vector contains all the regulation important values, such as the speed or torque reference signals, the speed or torque regulation error, the firing angle value, and so on, and Wm is the motor speed in rad/s. All input-output descriptions are available on the reference page of every model.

The motor speed (Wm) can be multiplied by the constant K of Equation 4-3 to obtain the load torque signal to be connected to the T_m input of the DC3 model:

- 1 Build the subsystem following and name it **Linear load torque**.

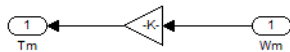

Linear Load Torque Subsystem

The constant K can be computed knowing that at nominal speed, the motor should develop nominal torque. As shown in DC3, 200 HP Drive Specifications, the DC motor used in this simulation has a nominal speed $N_{m,n}$ of 1750 rpm. Since the nominal mechanical output power $P_{m,n}$ of the motor is 200 hp, the nominal mechanical load torque $T_{mec,n}$ can be computed following Equation 4-4 (where viscous friction is neglected)

$$P_{m,n} = T_{mec,n} \cdot \omega_{m,n} = T_n \cdot \frac{\pi \cdot N_{m,n}}{30}$$

where $\omega_{m,n}$ is the nominal speed in rad/s. Using this equation, we find a nominal mechanical torque of 814 N.m. Finally Equation 4-3 gives us a K value of 4.44.

- 2 Set the constant value of the Linear load torque block to 4.44.
- 3 Connect the input and output of the Linear load torque block to W_m and T_m input of the DC3 block, respectively. Your schematic should now look like the following.

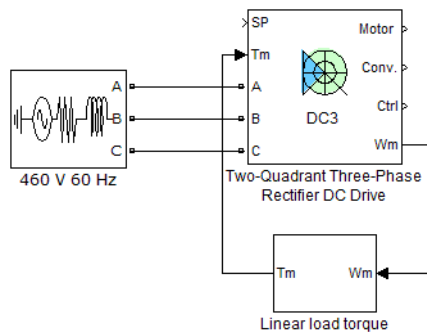

Building the Example Circuit

Defining the Set Point

The set point input of the DC3 model can either be a speed value (in rpm) or a torque value (in N.m) depending on the regulation mode (speed or torque regulation). In this example, we will set the DC3 block in speed regulation mode and drive the 200 hp DC motor to its nominal speed of 1750 rpm.

- 1 Open the Simulink Sources library and copy a Constant block into DC_example.
- 2 Connect the Constant block to the set point input of the DC3 model and name it Speed reference.
- 3 Set the set point to 1750 rpm.

Visualizing Internal Signals

You must now use the DC3 model outputs to visualize interesting signals with a scope. Suppose you need to visualize the following signals:

- The thyristor bridge firing angle
- The motor armature voltage

- The motor armature current and reference
- The speed reference and the motor speed

Note that all model input-output descriptions can be found in the corresponding reference notes. To see which signals are connected to the DC3 outputs, select the DC3 model and use the **Diagram > Mask > Look Under Mask** menu item.

As you can see below, the firing angle is contained inside the Ctrl output vector. The firing angle Alpha (see the DC3 block reference notes) is the second element of this vector.

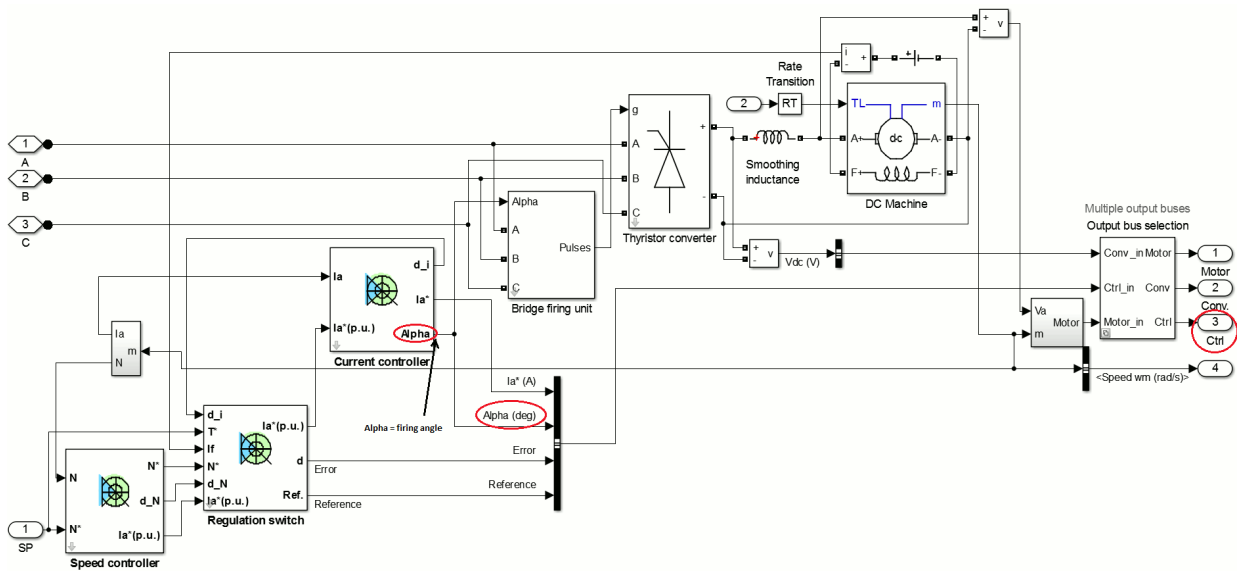

Location of the Firing Angle Signal Inside the Ctrl Output Vector

The Motor vector (shown in the next figure) contains three of the needed signals: the armature voltage and current signals are the first and third elements, respectively. The speed is the second element of the Motor vector.

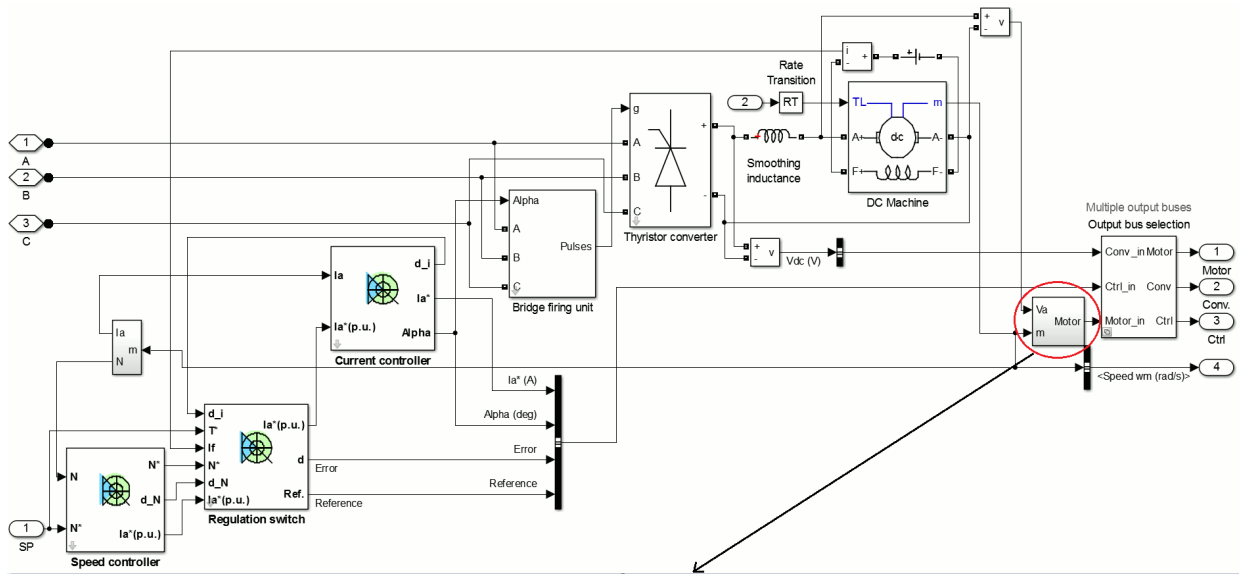

Motor Vector

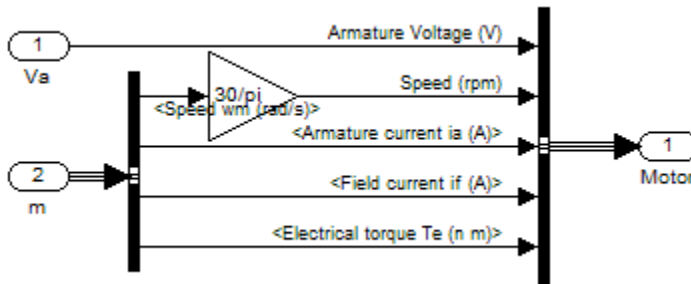

Finally, the current and speed reference signals are the first and fourth elements of the Ctrl vector, respectively (see the following figure). Note that the Ref. signal of the Regulation switch block would be a torque reference in torque regulation mode.

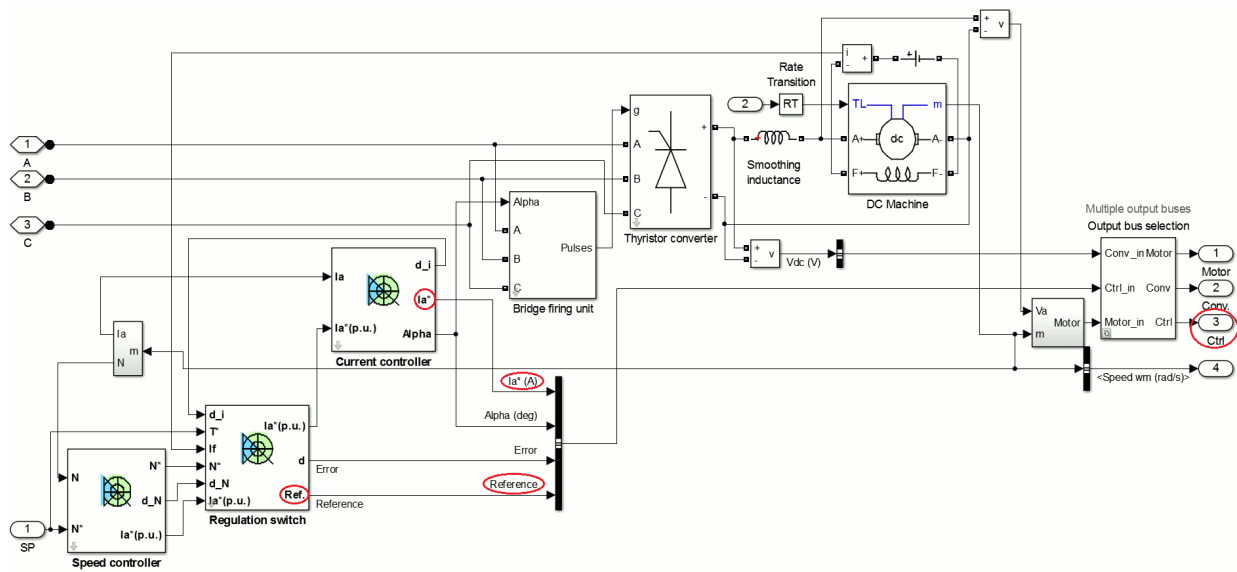

Location of the Speed Reference Signal Inside the Ctrl Output Vector

Internal bridge current and voltage signals can be extracted via the Conv. output, which is connected to a multimeter output. To view these signals, open the Measurements library and copy the **Multimeter** block into your circuit. By clicking the **Multimeter** block, you can select the converter signals you want to output. Refer to the **Multimeter** block reference page for more information on how to use the **Multimeter** block.

By using Selector blocks of the Signal Routing library, you can now extract the needed signals from the three output vectors in order to visualize them:

- 1 Build the following subsystem in order to extract all the needed visualization signals. Name it **Signal Selector**.

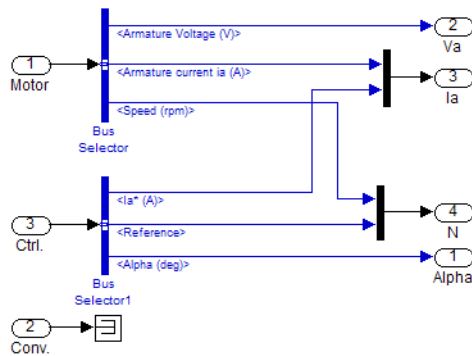

Signal Selector Subsystem

- 2 Connect the Motor, Conv., and Ctrl outputs of the DC3 block to the Motor, Conv., and Ctrl inputs of your Signal Selector block.
- 3 Copy two scopes to your model. They will be used to display the output signals of the Signal Selector block and the Multimeter block. For the first scope, open the **Scope Parameters** dialog box. On the **General** tab, set the number of axes to 4, the simulation time range to **auto**, and use a decimation of 20. Clear the **Limit Data Points to last** check box on the **Data history** tab. Connect the four outputs of the Signal Selector block to the inputs of the scope. Connect the output of the Multimeter block to the input of the second scope.

Setting the Fixed-Step Simulation Environment

All drive models of the library are discrete models. In order to simulate your system, you must now specify the correct simulation time step and set the fixed-step solver option. Recommended sample time values for DC drives, AC drives, and mechanical models can be found in the Remarks sections of the corresponding block reference pages. The recommended sample time for the DC3 model is 5 μs . Follow these steps:

- 1 Open the SimPowerSystems library and copy a Powergui block into DC_example. Open the Powergui, click **Configure Parameters**, and in the Powergui block parameters dialog box set **Simulation type** to **Discrete**. Set the sample time to 5 μs .

Your circuit should now look like Thyristor Converter-Based DC Motor Drive Example Circuit.

- Open the **Simulation/Configuration Parameters** dialog box. Select the **fixed-step, Discrete** (no continuous states) solver option. Set the stop time to 12 seconds.

Before simulating your circuit, you must first set the correct DC3 internal parameters.

Setting the High Power Drive Parameter Set

Many models of the Electric Drives library have two sets of parameters: a low-power set and a high-power set. By default, all models are initially loaded with the low-power set. The DC3 model parameters currently loaded in `DC_example` are those of a 5 hp drive.

You will now set the high-power drive parameters, which are those of a 200 hp drive. To do this, you will use the graphical user interface:

- Open the user interface by double-clicking the DC3 block. The interface is shown.

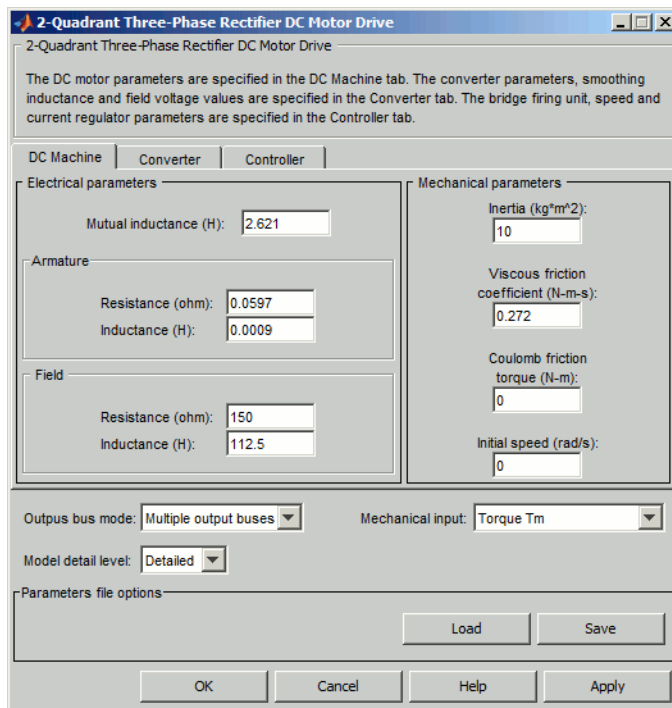

DC3 User Interface

The interface is divided following the three main parts of a drive system: the motor parameters (**DC Machine** tab), the converter parameters (**Converter** tab), and the regulation parameters of the drive controller (**Controller** tab).

- 2 To load the 200 hp parameters, click the **Load** button.

When you click the **Load** button, a window containing the low-power and high-power parameter files of every AC and DC model appears. These files contain all the parameters used by the graphical user interface. The name of each file begins with the model name followed by the power value. The 200 hp version of DC3 is thus named `dc3_200hp_params`.

- 3 In the parameters selection window, select the `dc3_200hp_params.mat` file and click **Load**.

The 200 hp parameters are now loaded. Note that you can also save custom drive parameters by using the **Save** button. When you do so, your custom parameters are saved in a MAT-file format and can be reloaded at any time.

Setting the Motor Inertia Value

All default inertias of the library drives are “no-load” inertias that only represent rotor inertias. When the motor is coupled to a load, the inertia field of the **DC Machine** tab represents the combined inertias of the rotor and of the driven load. In this example, the no-load inertia of the DC3 200 hp motor is $2.5 \text{ kg}\cdot\text{m}^2$. Since the drive is directly coupled to a load, you must increase this value by the inertia of the load. Suppose that the new combined inertia amounts to $15 \text{ kg}\cdot\text{m}^2$.

- 1 In the **DC Machine** section of the dialog box, change the inertia value to $15 \text{ kg}\cdot\text{m}^2$.
- 2 Click **OK** to apply the changes and close the dialog box.

Setting the DC3 Controller Parameters and Simulation Results

The speed and current controllers of the DC3 block are both composed of a proportional-integral regulator. More details on the regulators of each drive model of the library can be found on the corresponding block reference pages. To have a quick idea of the internal structure of a drive controller, a schematic is available inside the user interface of each model. Let's open the schematics related to our DC3 model:

- 1 Open the user interface. Click the **Controller** tab and then the **Schematic** button. You should see the controller schematics as shown in Controller Schematics of the User Interface.

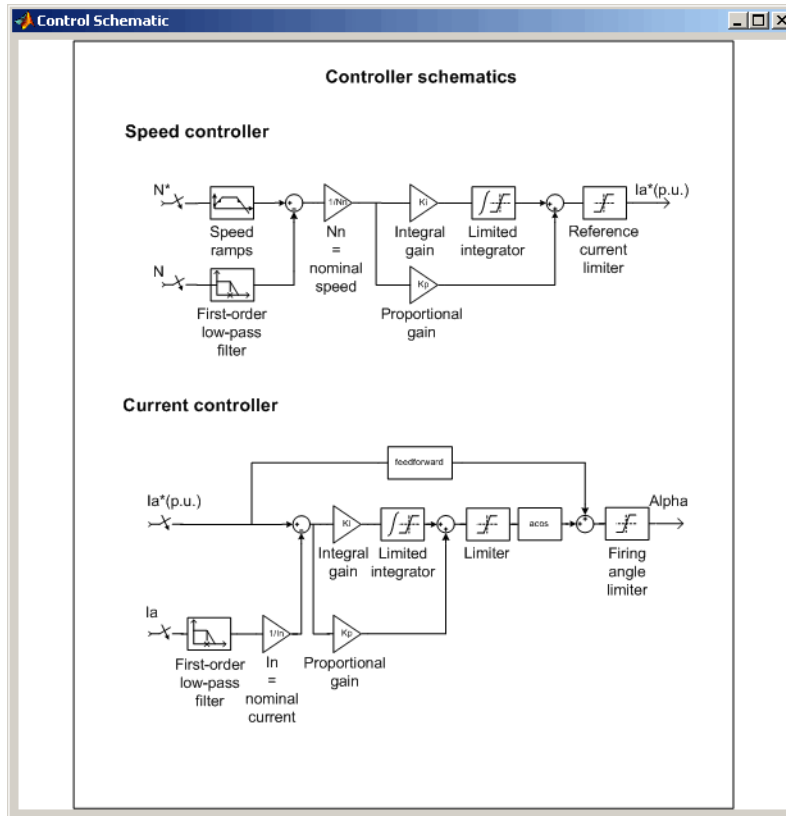

Controller Schematics of the User Interface

All default regulation parameters (speed and current controller parameters) have been trimmed for “no-load” inertias. Because the inertia has been modified, some changes are needed regarding the speed controller. The current controller should not be modified, the change of inertia having little influence on the current control.

In order to visualize the changes that need to be made, run a simulation of the present circuit.

- 2 Start the simulation. The simulation results visualized on the scope are shown below.

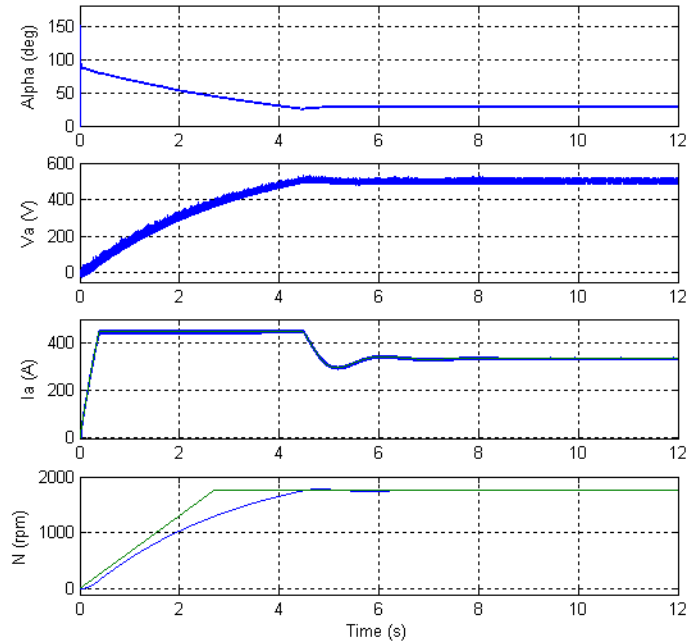

Simulation Results

Notice that the armature current follows its reference very well, but saturates at 450 A during the accelerating phase. This saturation is a result of the current controller reference limit of 1.5 pu. This results in insufficient acceleration torque, and the motor is unable to follow the 650 rpm/s default speed ramp. Since the acceleration torque cannot be increased (this would result in a burnout of the armature circuit), the speed ramp must be lowered. A guideline is to lower the speed ramp by the same amount that the inertia was increased. Indeed, following the equation below, the same torque vs. speed curve (or current vs. speed) as the default one obtained with a $2.5 \text{ kg}\cdot\text{m}^2$ inertia can be obtained with the new inertia I , if the speed ramp $\dot{\omega}$ is reduced by an amount equal to the inertia increase.

$$T_{em}(\omega) = I \cdot \dot{\omega} + T_{mec} + B \cdot \omega = I \cdot \dot{\omega} + K' \cdot \omega + B \cdot \omega$$

The $B \cdot \omega$ term represents the viscous friction in the drive where B is the viscous friction coefficient.

In this case, we decrease the speed ramp slightly less than the inertia increase in order to have a high enough acceleration, and set it to 200 rpm/s.

- 3 Open the user interface. In the **Controller** section, set the acceleration speed ramp parameter of the speed controller menu to 200 rpm/s.

The screenshot shows the '2-Quadrant Three-Phase Rectifier DC Motor Drive' configuration window. The 'Controller' tab is selected, and the 'Speed Controller' sub-tab is active. The 'Acceleration' parameter is highlighted with a red oval and set to 650 rpm/s. Other parameters include: Nominal speed (1750 rpm), Initial speed reference (0 rpm), Low-pass filter cutoff frequency (40 Hz), Proportional gain (10), Integral gain (50), Deceleration (-650 rpm/s), Output bus mode (Multiple output buses), Mechanical input (Torque Tm), and Model detail level (Detailed).

Parameter	Value
Regulation type	Speed regulation
Sampling time (s)	100e-6
Nominal speed (rpm)	1750
Initial speed reference (rpm)	0
Low-pass filter cutoff frequency (Hz)	40
Proportional gain	10
Integral gain	50
Acceleration (rpm/s)	650
Deceleration (rpm/s)	-650

Change of the Acceleration Speed Ramp Parameter

- 4 Start the simulation and observe the new results on the scope.

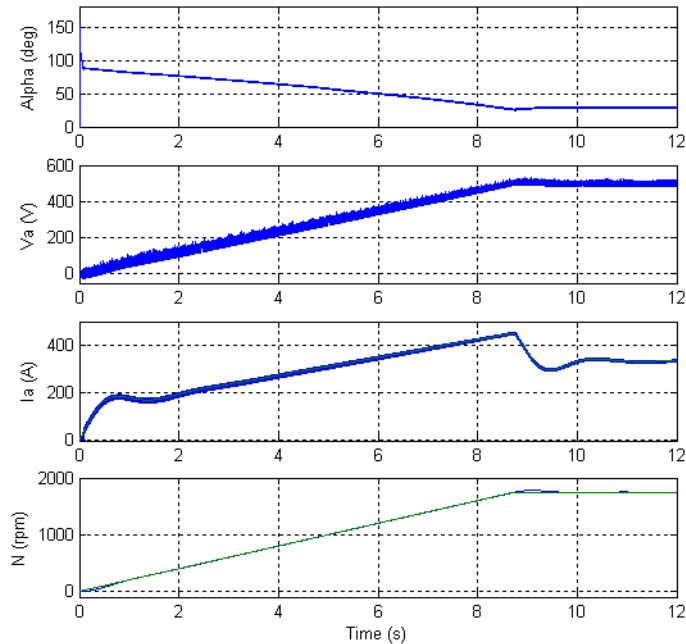

Simulation Results with a New Acceleration Speed Ramp Value

The current regulation is very good, and no current regulator changes will be undertaken. The speed regulation is satisfactory, but some improvements could be made: the initial tracking of the speed reference could be faster, and the speed overshoot and the small speed ramping error encountered during the accelerating phase could be reduced. A modification of the proportional and integral gains of the PI speed regulator will allow you to achieve these goals:

- By increasing the proportional gain of the speed controller, you increase the controller's sensitivity by making it react a lot faster to small speed regulation errors. This allows a better initial tracking of the speed reference by a faster reaction of the current reference issued by the speed controller. This increased sensitivity also reduces the speed overshooting, the armature current being reduced a lot faster once the desired speed is reached.

- An increase of the integral gain will allow the motor speed to catch up with the speed reference ramp a lot faster during ramping periods. This will indeed allow a faster reaction to small speed error integral terms that occur when a signal is regulated following a ramp. The controller will react in order to diminish the speed error integral a lot faster by producing a slightly higher acceleration torque when following an acceleration ramp.

Be aware that too high an increase of the proportional and integral gains can cause instability, the controller becoming oversensitive. Too high gains can also cause current saturation. An easy way to adjust the speed controller gains is to increase them step by step and to simulate the new configuration after each change until the desired system performances are obtained (trial/error method).

Note that when the current controller has to be trimmed, a good way to achieve this is to keep the rotor still by setting a very high combined inertia value. This allows a decoupling of the electrical and mechanical parameters. You then adjust the current controller parameters until the current follows given current references perfectly. The same remarks can be made for the current regulator as those made above for speed regulation. Once the current regulator is trimmed, you can then trim the speed regulator by resetting the combined inertia to its initial value.

- 5 Try different speed regulator values and observe the resulting changes in the system dynamics. A proportional gain of 80 and an integral gain of 200 give very good results, as shown.

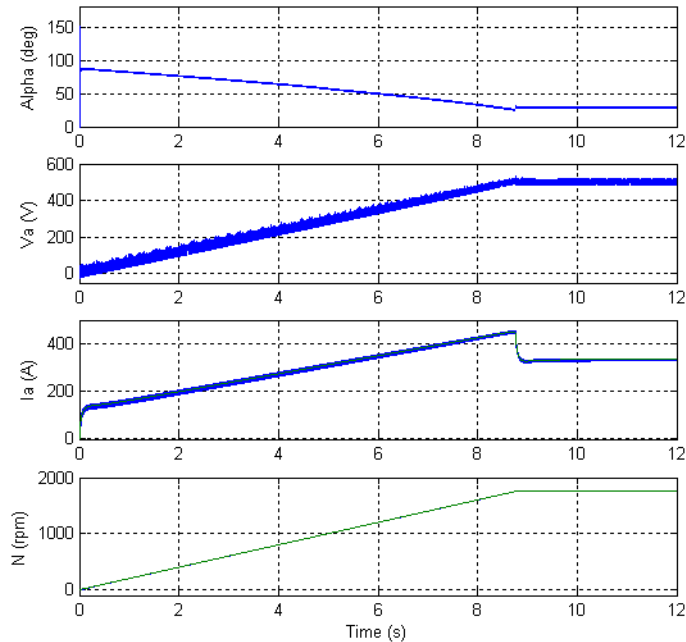

Simulation Results with Trimmed Speed Regulator Parameters

Observe that the firing angle value lowers with the speed increase in order to generate a growing converter output voltage. The converter is here working in rectifier mode, the power transiting from the AC source to the DC motor. The voltage increase allows the converter to keep feeding current to the DC motor during the acceleration phase, the armature voltage increasing proportionally with the speed. The current increase observed during this phase is due to the increasing torque opposed by the load. Around $t = 8.5$ s, the speed reaches its set point, and the armature current lowers to about 335 A since no more acceleration torque is needed.

Before concluding this example, notice the two first-order filters used in the speed and current controllers of Controller Schematics of the User Interface. These filters remove unwanted current and speed harmonics in the current and speed measurement signals. These harmonics are caused by the rectified output voltages of the three-phase full converters. The main ripple frequency introduced by a three-phase full converter is equal

to six times the voltage source frequency (6th harmonic). In the case of this example, the first harmonic frequency is thus equal to 360 Hz. The cutoff frequency of the first-order filters must at least be lower than 360 Hz. Since the filters are first-order filters, the cutoff frequency must be a lot lower to have a reasonably good harmonic rejection. Keep in mind that too low a cutoff frequency can cause system instability. In the case of chopper drives like DC5, DC6, and DC7, the fundamental frequency is equal to the PWM frequency.

Simulating in Average-Value Mode

Most drive models can be simulated in average-value mode. In such mode, the Universal Bridge blocks used to simulate the power converters driving the motors are replaced by average-value converters. The average-value converter models used are described in the reference pages of each drive model. This lets you increase the simulation time step and thus increase simulation speed.

Use the following procedure to simulate a model in average-value mode.

- 1 Open the user interface. Select the **Average** option in the **Model detail level** drop-down list located in the lower part of the user interface, as shown in the following illustration.

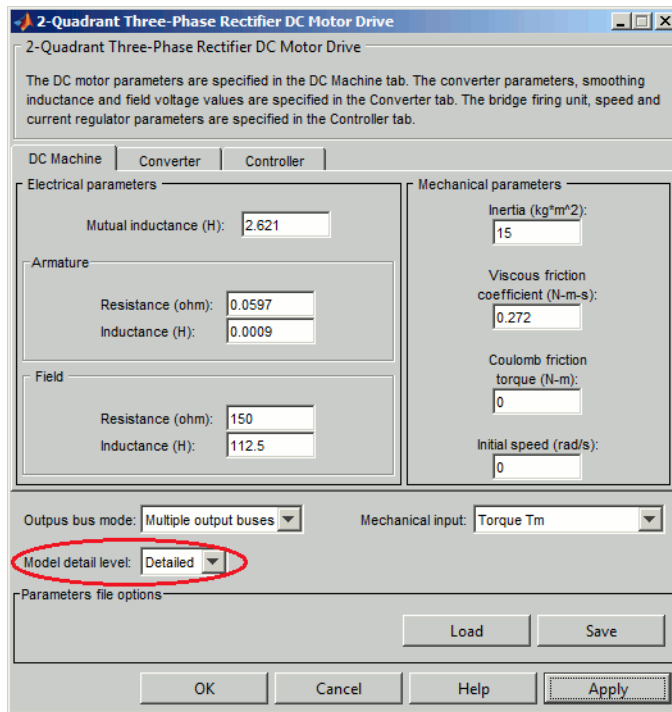

Selecting the Average-Value Simulation Mode

- 2 Select the **Converter** section.

Notice that it contains some extra parameters specific to average-value mode. These parameters affect the external voltage source and are used by the average-value rectifier. All parameters are described in the reference pages.

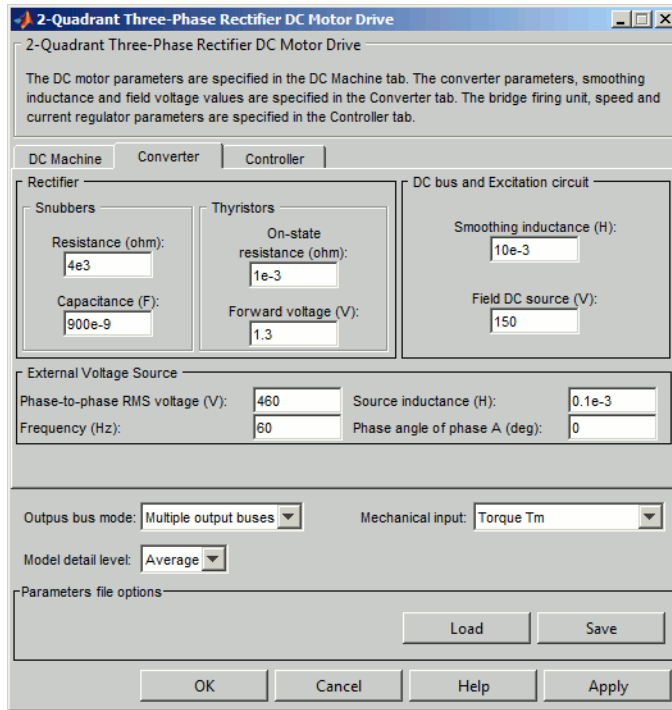

Extra Parameters Used in Average-Value Mode

When simulating in average-value mode, the time step can be increased in order to run faster simulations. A guideline is to increase the time step up to the smallest controller sampling time used in the model. In this case the sampling time is the same for the speed and current controllers and is equal to 100 μ s.

- 3 Close the user interface and open the Powergui block. Click **Configure Parameters**, and in the Powergui block parameters dialog box set **Simulation type** to **Discrete**. Set the sample time to 100 μ s. Run the simulation.

Notice that the simulation time is reduced. Observe the simulation results: the rectifier output voltage and current ripples are not represented, you can see only the average value of these signals. If you later try to visualize the input current, you will only see the 60 Hz fundamental component of the detailed current.

Simulate an AC Motor Drive

In this section...

“Introduction” on page 4-33

“Dynamic Braking” on page 4-33

“Modulation Techniques” on page 4-34

“Open-Loop Volts/Hertz Control” on page 4-38

“Closed-Loop Speed Control with Slip Compensation” on page 4-40

“Flux-Oriented Control” on page 4-40

“Direct Torque Control” on page 4-43

“Example: AC Motor Drive” on page 4-44

Introduction

In this section, you will learn how to use the AC drive models of the Electric Drives library. First, we will specify the types of motors, converters, and controllers used in the six AC drive models of the library designated AC1 to AC6. The AC1, AC2, AC3, and AC4 models are based on the three-phase induction motor. This motor has a three-phase winding at the stator and a wound rotor or a squirrel-cage rotor. The squirrel-cage rotor consists of slots of conducting bars embedded in the rotor iron. The conducting bars are short-circuited together at each end of the rotor by conducting rings. The AC5 model is based on a wound rotor synchronous motor, and the AC6 model uses a permanent magnet synchronous motor. The models of these three types of motors are available in the Machines library. These AC motors are fed by a variable AC voltage and frequency produced by an inverter. The type of inverter used in the six AC drive models is a voltage source inverter (VSI) in the sense that this inverter is fed by a constant DC voltage. This constant voltage is provided by an uncontrolled diode rectifier and a capacitor (capacitive DC bus voltage).

Dynamic Braking

When the DC bus is provided by a diode rectifier, the drive doesn't have a bidirectional power flow capability and therefore cannot perform regenerative braking. In the AC1, AC2, AC3, AC4, and AC6 models, a braking resistor in series with a chopper ensures the braking of the motor-load system. This braking scheme is called dynamic braking.

It is placed in parallel with the DC bus in order to prevent its voltage from increasing when the motor decelerates. With dynamic braking, the kinetic energy of the motor-load system is converted into heat dissipated in the braking resistor.

Modulation Techniques

The VSI inverters used in the AC drive models of the library are based on two types of modulation, hysteresis modulation and space vector pulse width modulation (PWM).

The hysteresis modulation is a feedback current control method where the motor current tracks the reference current within a hysteresis band. The following figure shows the operation principle of the hysteresis modulation. The controller generates the sinusoidal reference current of desired magnitude and frequency that is compared with the actual motor line current. If the current exceeds the upper limit of the hysteresis band, the upper switch of the inverter arm is turned off and the lower switch is turned on. As a result, the current starts to decay. If the current crosses the lower limit of the hysteresis band, the lower switch of the inverter arm is turned off and the upper switch is turned on. As a result, the current gets back into the hysteresis band. Hence, the actual current is forced to track the reference current within the hysteresis band.

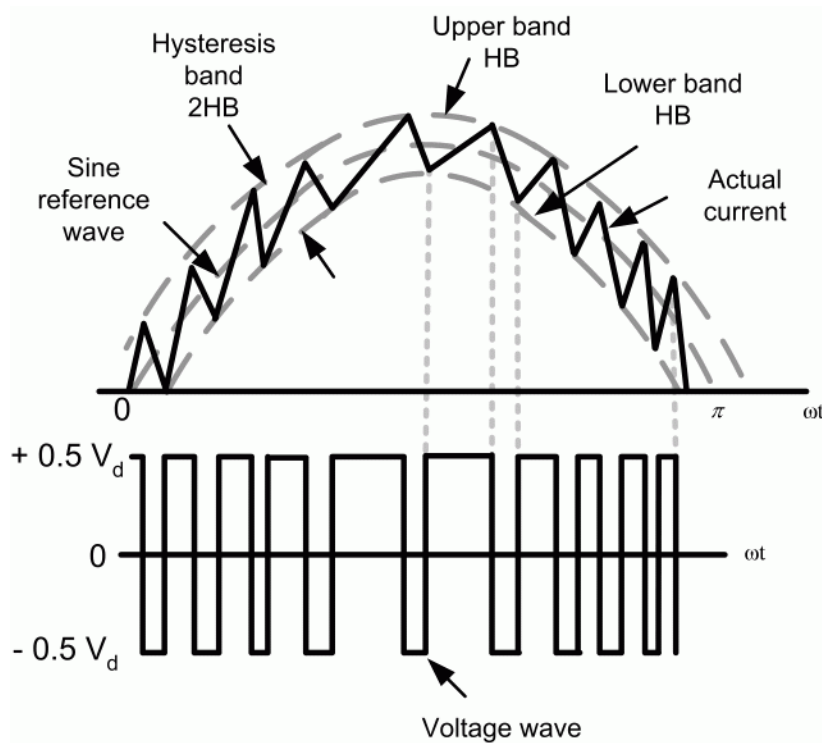

Operation Principle of Hysteresis Modulation

The following figure shows the hysteresis current control modulation scheme, consisting of three hysteresis comparators, one for each phase. This type of closed-loop PWM is used in AC3 and AC5 models.

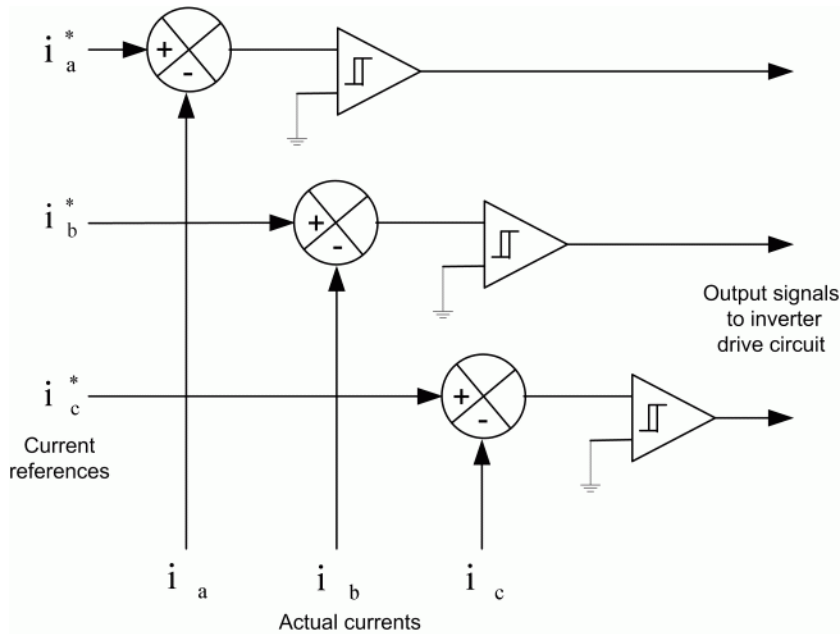

Typical Hysteresis Current Controller

The space vector modulation technique differs from the hysteresis modulation in that there are not separate comparators used for each of the three phases. Instead, a reference voltage space vector V_s is produced as a whole, sampled at a fixed frequency, and then constructed through adequate timing of adjacent nonzero inverter voltage space vectors V_1 to V_6 and the zero voltage space vectors V_0 , V_7 . A simplified diagram of a VSI inverter is shown below. In this diagram, the conduction state of the three legs of the inverter is represented by three logic variables, SA, SB, and SC. A logical 1 means that the upper switch is conducting and logical 0 means that the lower switch is conducting.

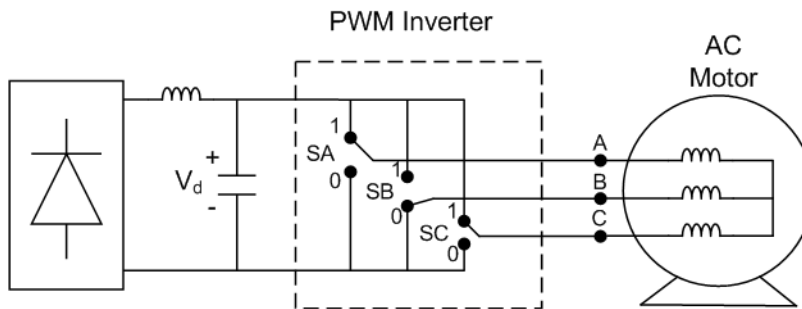

Simplified Diagram of a VSI PWM Inverter

In this diagram, the conduction state of the three legs of the inverter is represented by three logic variables, SA, SB, and SC. A logical 1 means that the upper switch is ON and logical 0 means that the lower switch is ON.

The switching of SA, SB, SC results in eight states for the inverter. The switching states and the corresponding phase to neutral voltages are summarized in Inverter Space Voltage Vectors. The six active vectors are an angle of 60 degrees apart and describe a hexagon boundary. The two zero vectors are at the origin.

For the location of the V_s vector shown in Inverter Space Vector Voltages, as an example, the way to generate the inverter output is to use the adjacent vectors V_1 and V_2 on a part-time basis to satisfy the average output demand. The voltage V_s can be resolved as:

$$V_b = \frac{2}{\sqrt{3}} V_s \cdot \sin \delta$$

$$V_a = V_s \cdot \cos \delta - \frac{1}{2} V_b$$

V_a and V_b are the components of V_s along V_1 and V_2 , respectively. Considering the period T_c during which the average output must match the command, write the time durations of the two states 1 and 2 and the zero voltage state as:

$$t_a = \frac{3}{2} \cdot \frac{V_a}{V_d} \cdot T_c$$

$$t_b = \frac{2}{3} \cdot \frac{V_b}{V_d} \cdot T_c$$

$$t_z = T_c - (t_a + t_b)$$

Inverter Space Voltage Vectors

State	SA	SB	SC	Inverter Operation	Space Voltage Vector
0	1	1	1	Freewheeling	V_0
1	1	0	0	Active	V_1
2	1	1	0	Active	V_2
3	0	1	0	Active	V_3
4	0	1	1	Active	V_4
5	0	0	1	Active	V_5
6	1	0	1	Active	V_6
7	0	0	0	Freewheeling	V_7

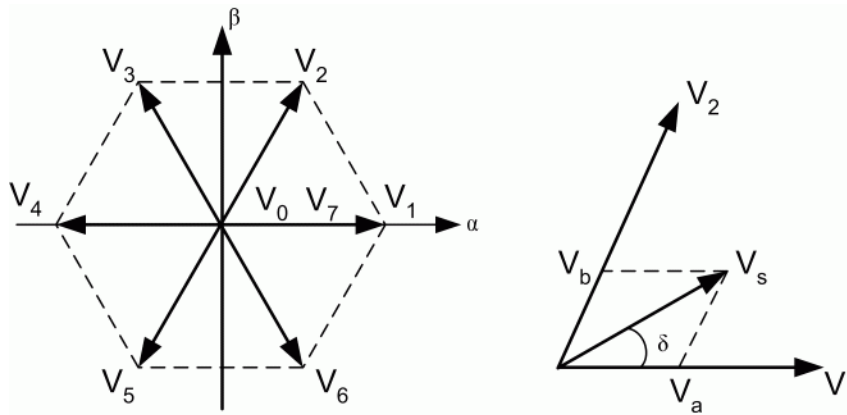

Inverter Space Vector Voltages

Open-Loop Volts/Hertz Control

The AC machine stator flux is equal to the stator voltage to frequency ratio since

$$\varphi(t) = \int v(t) dt$$

where

$$v(t) = \sqrt{2} \cdot V \cdot \sin(\omega \cdot t)$$

therefore

$$\varphi(t) = \frac{\sqrt{2} \cdot V}{\omega} \cdot \cos(\omega \cdot t)$$

Since the motor is fed with a variable AC source voltage and frequency, it is important to maintain the volts/Hz constant in the constant torque region if magnetic saturation is to be avoided. A typical volts/Hz characteristic is shown below. Notice that the straight line has a small voltage boost in order to compensate for resistance drop at low frequency. Open-loop volts/Hz control is used with low-dynamics applications such as pumps or fans where a small variation of motor speed with load is tolerable. The AC1 model is based on an open-loop volts/Hz controller.

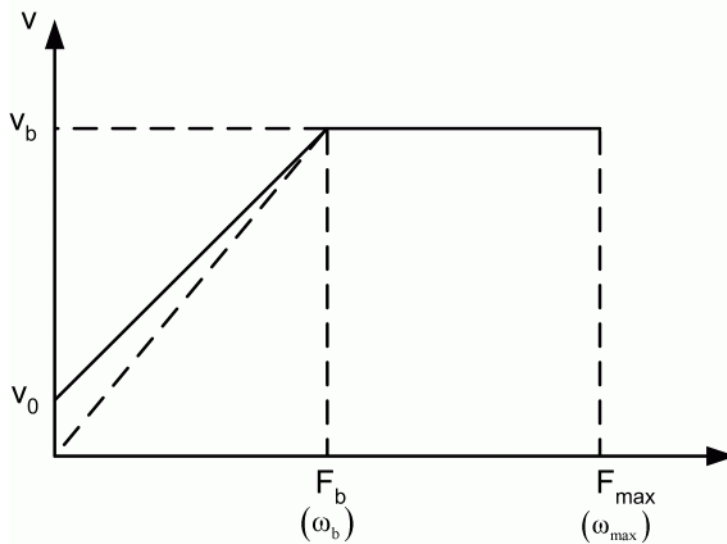

Volts/Hz Characteristics with Compensation at Low Frequency

Closed-Loop Speed Control with Slip Compensation

In this type of control, a slip speed command is added to the measured rotor speed to produce the desired inverter frequency. A PI-based speed regulator produces the slip command. The desired inverter frequency generates the voltage command through a volts/Hz characteristic such as the one shown above. The AC2 model is based on a closed-loop speed control that uses volts/Hz and slip regulation.

Flux-Oriented Control

The construction of a DC machine is such that the field flux is perpendicular to the armature flux. Being orthogonal, these two fluxes produce no net interaction on one another. Adjusting the field current can therefore control the DC machine flux, and the torque can be controlled independently of flux by adjusting the armature current. An AC machine is not so simple because of the interactions between the stator and the rotor fields, whose orientations are not held at 90 degrees but vary with the operating conditions. You can obtain DC machine-like performance in holding a fixed and orthogonal orientation between the field and armature fields in an AC machine by orienting the stator current with respect to the rotor flux so as to attain independently controlled flux and torque. Such a control scheme is called flux-oriented control or vector control. Vector control is applicable to both induction and synchronous motors. We will see now how it applies to induction motors.

Considering the d-q model of the induction machine in the reference frame rotating at synchronous speed ω_e ,

$$V_{qs} = R_s i_{qs} + \frac{d}{dt} \varphi_{qs} + \omega_e \varphi_{ds}$$

$$V_{ds} = R_s i_{ds} + \frac{d}{dt} \varphi_{ds} - \omega_e \varphi_{qs}$$

$$0 = R_r i_{qr} + \frac{d}{dt} \varphi_{qr} + (\omega_e - \omega_r) \varphi_{dr}$$

$$0 = R_r i_{dr} + \frac{d}{dt} \varphi_{dr} - (\omega_e - \omega_r) \varphi_{qr}$$

$$T_e = 1.5 p \frac{L_m}{L_r} (\varphi_{dr} i_{qs} - \varphi_{qr} i_{ds})$$

where

$$\varphi_{qs} = L_s i_{qs} + L_m i_{qr}$$

$$\varphi_{ds} = L_s i_{ds} + L_m i_{dr}$$

$$\varphi_{qr} = L_r i_{qr} + L_m i_{qs}$$

$$\varphi_{dr} = L_r i_{dr} + L_m i_{ds}$$

The field-oriented control implies that the i_{ds} component of the stator current would be aligned with the rotor field and the i_{qs} component would be perpendicular to i_{ds} . This can be accomplished by choosing ω_e to be the speed of the rotor flux and locking the phase of the reference frame system such that the rotor flux is aligned precisely with the d axis, resulting in

$$\varphi_{qr} = 0 \Rightarrow \frac{d}{dt} \varphi_{qr} = 0$$

and

$$\varphi_{dr} = \varphi_r$$

which implies that

$$\omega_{sl} = (\omega_e - \omega_r) = \left(\frac{L_m R_r}{\varphi_r L_r} \right) i_{qs}$$

and that

$$T_e = 1.5 p \frac{L_m}{L_r} (\varphi_r i_{qs})$$

It also follows that

$$\frac{d}{dt} \varphi_r = - \left(\frac{R_r}{L_r} \right) \varphi_r + \left(\frac{L_m R_r}{L_r} \right) i_{ds}$$

The analogy with DC machine performance is now clear. The electric torque is proportional to the i_{qs} component, whereas the relation between the flux φ_r and the i_{ds} component is given by a first-order linear transfer function with a time constant L_r / R_r .

You cannot directly measure the rotor flux orientation in a squirrel-cage rotor induction machine. It can only be estimated from terminal measurements. An alternative way is to use the slip relation derived above to estimate the flux position relative to the rotor, as shown. The latter control scheme is called indirect field-oriented control and is used in the AC3 model.

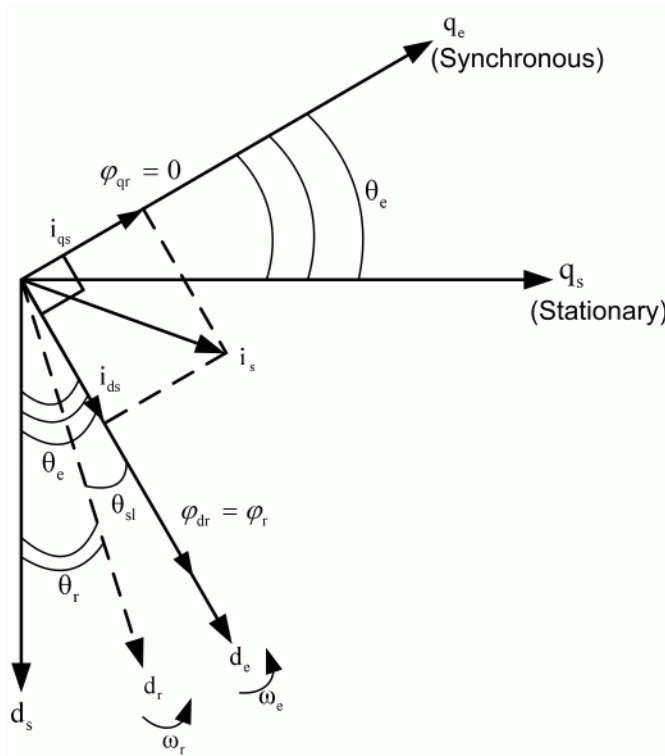

Rotor Flux Position Obtained from the Slip and Rotor Positions

Direct Torque Control

The field-oriented control is an attractive control method but it has a serious drawback: it relies heavily on precise knowledge of the motor parameters. The rotor time constant is particularly difficult to measure precisely, and to make matters worse it varies with temperature.

A more robust control method consists first in estimating the machine stator flux and electric torque in the stationary reference frame from terminal measurements. The following relations are used

$$\varphi_{ds} = \int (V_{ds} - R_s i_{ds}) dt$$

$$\varphi_{qs} = \int (V_{qs} - R_s i_{qs}) dt$$

$$\hat{\varphi}_s = \sqrt{\varphi_{ds}^2 + \varphi_{qs}^2} \angle \text{atan} \left(\frac{\varphi_{qs}}{\varphi_{ds}} \right)$$

$$T_e = 1.5 p (\varphi_{ds} i_{qs} - \varphi_{qs} i_{ds})$$

The estimated stator flux and electric torque are then controlled directly by comparing them with their respective demanded values using hysteresis comparators. The outputs of the two comparators are then used as input signals of an optimal switching table. The following table outputs the appropriate switching state for the inverter.

Switching Table of Inverter Space Vectors

H_ψ	H_{T_e}	S(1)	S(2)	S(3)	S(4)	S(5)	S(6)
	1	V_2	V_3	V_4	V_5	V_6	V_1
1	0	V_0	V_7	V_0	V_7	V_0	V_7
	-1	V_6	V_1	V_2	V_3	V_4	V_5
	1	V_3	V_4	V_5	V_6	V_1	V_2
-1	0	V_7	V_0	V_7	V_0	V_7	V_0
	-1	V_5	V_6	V_1	V_2	V_3	V_4

Example: AC Motor Drive

In this example, you will build and simulate the simple induction motor drive system in Induction Motor Drive Example Circuit.

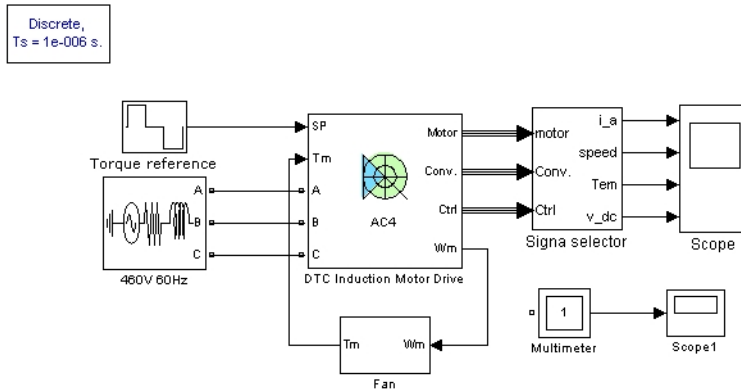

Induction Motor Drive Example Circuit

This step-by-step example illustrates the use of the AC4 model with a 200 hp induction motor parameter set during torque regulation. The AC4 block models a DTC drive. During this example, the motor is connected to a fan and its reaction to torque steps is simulated.

In this tutorial, you learn about

- “Getting the AC4 Model from the Electric Drives Library” on page 4-45
- “Connecting the AC4 Model to a Voltage Source” on page 4-45
- “Connecting the AC4 Model to a Mechanical Load” on page 4-46
- “Defining the Set Point” on page 4-47
- “Setting the Fixed-Step Simulation Environment” on page 4-50
- “Setting the Fixed-Step Simulation Environment” on page 4-50
- “Setting the High Power Drive Parameter Set” on page 4-51
- “Setting the Motor Inertia Value” on page 4-52
- “Setting the Braking Chopper Resistance Value” on page 4-53
- “Setting the DC Bus Initial Voltage Value” on page 4-54

- “Setting the AC4 Controller Parameters” on page 4-55

Getting the AC4 Model from the Electric Drives Library

- 1 Open a new window and save it as `ac_example`.
- 2 Open the Electric Drives library. You can open the library by typing `electricdrivelib` in the MATLAB Command Window or by using the Simulink Library Browser. The AC4 model is located inside the AC drives library. Copy the AC4 block and drop it in the `ac_example` window.

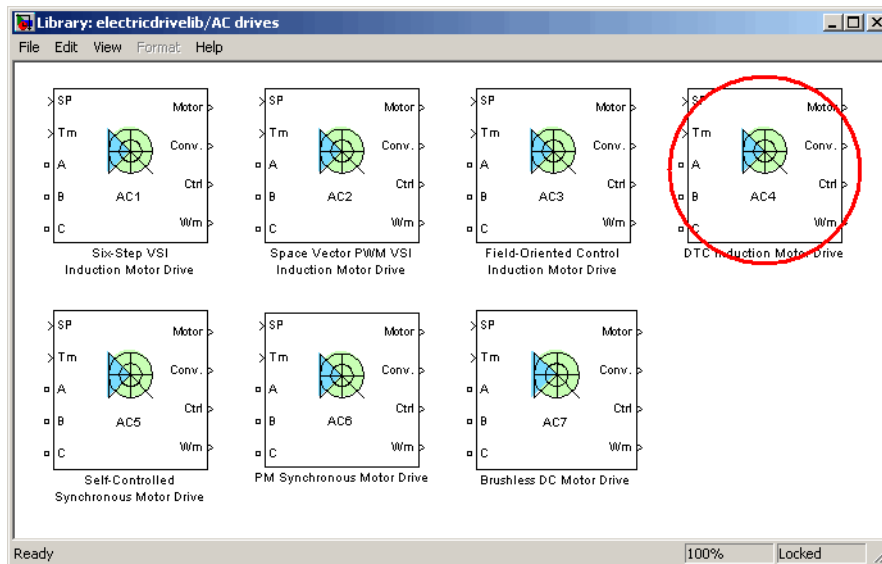

AC4 Model Inside the Drives Library

Connecting the AC4 Model to a Voltage Source

As with the DC example, you must now connect the AC4 block to a proper voltage source:

- 1 Open the Electrical Sources library and copy the **Three-Phase Source** block into your circuit. Connect the voltage source outputs A, B, and C to the AC4 A, B, and C inputs, respectively.

In this example, we will be driving a 200 hp induction motor of 460 V nominal armature voltage and 60 Hz nominal frequency. As specified in the DC example, the

voltage source amplitude and frequency values needed for each drive model of the Electric Drives library can be found in the reference notes. The nominal values of the corresponding motors are also included. The following table contains the values corresponding to the AC4 200 hp model.

AC4, 200 HP Drive Specifications

Drive Input Voltage	
Amplitude	460 V
Frequency	60 Hz
Motor Nominal Values	
Power	200 hp
Speed	1800 rpm
Voltage	460 V

Set the AC source voltage amplitude and frequency values to 460 V and 60 Hz, respectively.

- 2 Set the AC source phase-to-phase rms voltage value to 460 V, and the frequency to 60 Hz. Name the AC source **460 V 60 Hz**.

To represent a real-life three-phase source, you must specify correct source resistance R and inductance L values. The procedure to determine these values is described in the example, “Connecting the DC3 Model to a Voltage Source” on page 4-13. Following this procedure, you determine a resistance value of 0.0056 Ω and an inductance value of 0.15 mH.

- 3 Set the AC source resistance value to 0.0056 Ω and the inductance to 0.15 mH.

Connecting the AC4 Model to a Mechanical Load

The T_m input of the AC4 block represents the load torque applied to the shaft of the induction motor. In this case, the load torque is opposed by a fan. This type of torque is typically a quadratic function of the speed, as shown in Equation 4-5:

$$T_m = K \cdot \omega_m^2 = K' \cdot N_m^2$$

where ω_m is the speed in rad/s and N_m is the speed in rpm.

- 1 Build the subsystem of the following figure and name it **Fan**.

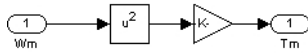

Fan Block

The constant K must be imposed so that at nominal speed, the motor develops nominal torque. This torque can be determined using Equation 4-4. Using this equation, there is a nominal value of 790 N.m. Finally, Equation 4-5 gives a K value of 0.022.

- 2 Set the constant value K to 0.022.
- 3 Connect the Fan block to the block. Your schematic should now look like the following schematic.

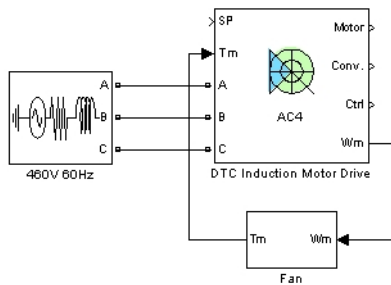

Building the Example Circuit

Defining the Set Point

Now define the set point (SP) input of AC4. For this example, the induction motor torque is controlled and a series of torque set points is imposed. A series of set points can be defined with the help of the Timer block.

- 1 Open the Control Blocks section of the Extra library and copy the Timer into ac_example. Connect the block to the set point input of the AC4 model and name it Torque reference.

The Timer block generates a signal changing at specified times. During this example, generate the following torque series.

Torque Set Point Series

t (s)	Torque Set Point (N.m)
0	0
0.02	600
0.25	0
0.5	-600
0.75	0

- 2 Set the **Time** field of the Timer block to [0.02 0.25 0.5 0.75]. Set the **Amplitude** field of the Timer block to [600 0 -600 0].

Visualizing Internal Signals

Use the AC4 model outputs to visualize interesting signals such as:

- The motor torque value and set point
- The motor speed
- The motor flux modulus
- The motor statoric currents
- The DC bus voltage

All motor variable values can be read via the Motor vector. The Conv. vector contains all converter related data. The Ctrl vector includes all reference signals and other control values.

The contents of the Conv. vector can be easily determined by adding a Multimeter block to the model. The DC bus voltage, named UDC: AC4/Rectifier_3ph, is the 10th signal of output vector Conv.

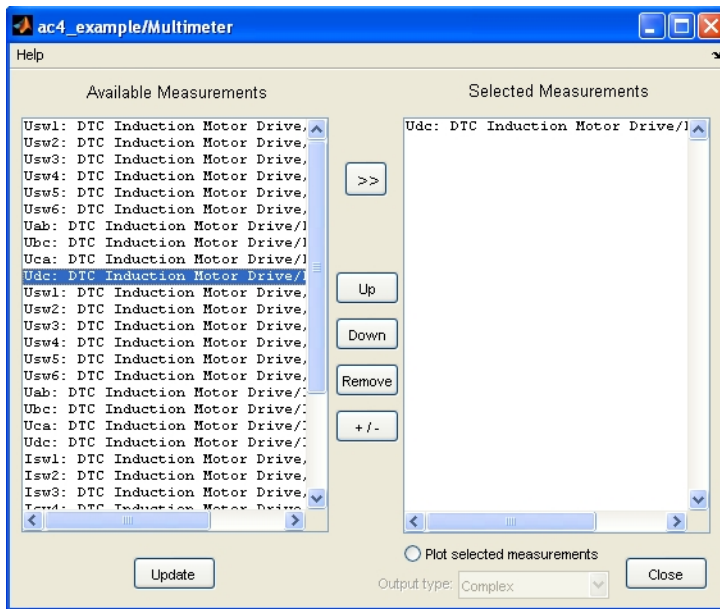

Multimeter Window

Following the input-output description of the reference notes, the torque reference signal is the first signal of output vector Ctrl.

- 1 Build the following subsystem to extract all the needed visualization signals. Name the subsystem **Signal Selector**.

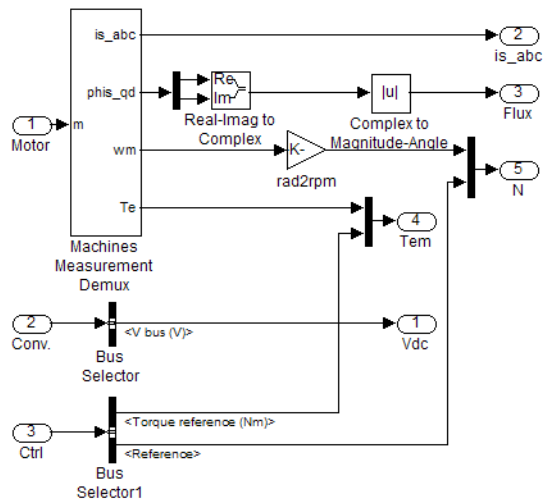

Signal Selector Subsystem

The rad2rpm block contains the constant $30/\pi$ to convert the rotor speed from rad/s to rpm. A Real-Imag to Complex block and a Complex to Magnitude-Angle block compute the magnitude of the flux vector.

- Copy a scope to your model to display the output signals of the Signal Selector block. Open the **Scope Parameters** dialog box. On the **General** tab, set the number of axes to 5, set the simulation time range to **auto**, and use a decimation of **25**. Clear the **Limit Data Points to last** check box on the **Data history** tab. Connect the five outputs of the Signal Selector block to the inputs of the scope.

Setting the Fixed-Step Simulation Environment

All drive models of the library are discrete models. To simulate your system, you must now specify the correct simulation time step and set the fixed-step solver option. Recommended sample time values for DC drives, AC drives, and mechanical models are in the Remarks sections of the corresponding block reference pages. The recommended sample time for the AC4 model is 1 μ s.

- Open the SimPowerSystems library and copy a **Powergui** block into **ac_example**. Open the Powergui, click **Configure Parameters**, and in the Powergui block

parameters dialog box set **Simulation type** to **Discrete**. Set the sample time to 1 μ s.

Your circuit should now look like Induction Motor Drive Example Circuit.

- 2 Open the **Simulation/Configuration Parameters** dialog box. Select the **fixed-step, Discrete (no continuous states)** solver option. Set the stop time to 1 s and the fixed-step size to Ts.

Before simulating your circuit, you must first set the correct AC4 internal parameters.

Setting the High Power Drive Parameter Set

As explained in the DC example, many drive models of the Electric Drives library have two sets of parameters: a low power set and a high power set. By default, all models are initially loaded with the low power set. The AC4 model parameters currently loaded in `ac4_example` are those of a 3 hp drive.

You now set the high power drive parameters, which are those of a 200 hp drive. To do this, you use the **Load** button of the user interface as specified in the DC example:

- 1 Open the user interface by double-clicking the AC4 block. The interface is shown below:

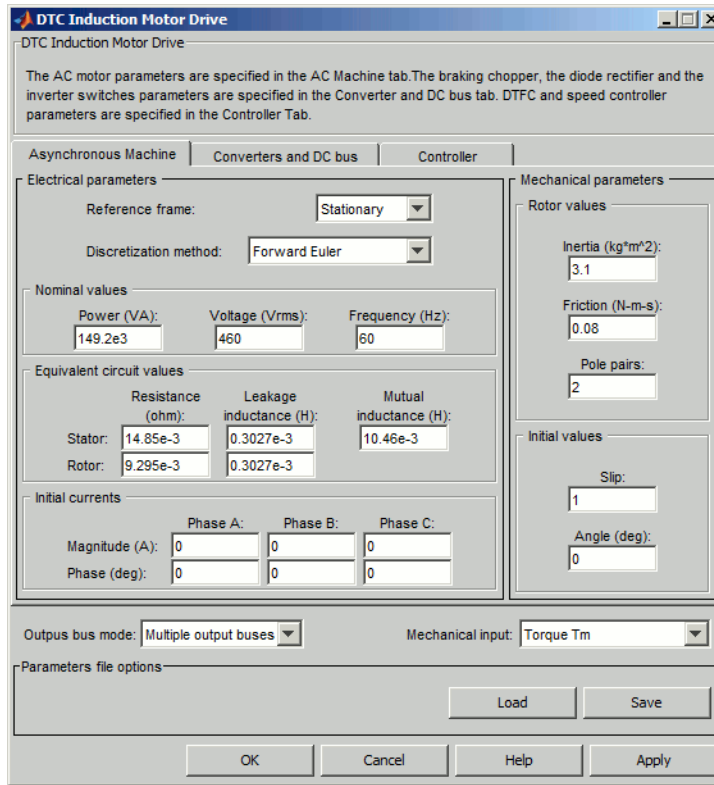

AC4 User Interface

- 2 To load the 200 hp parameters, click the **Load** button.
- 3 Select the ac4_200hp.matfile and click **Load**.

The 200 hp parameters are now loaded.

Setting the Motor Inertia Value

You must now set the motor inertia value. Note that the inertia values currently specified in each AC and DC model are “no-load” inertias that only represent the inertia of the rotor. If the motor is coupled to a load, these values must be increased by the load inertias. In this case, the current value of the inertia amounts to $3.1 \text{ kg}\cdot\text{m}^2$. Assume that the combined inertia of the motor and the fan amounts to $10 \text{ kg}\cdot\text{m}^2$. Note that the use of a flexible shaft connected between the motor and the fan would allow decoupling of

the motor and load inertias. In that case, the inertia value of the AC4 block would only be the sum of the rotor and shaft inertias.

- 1 In the **Asynchronous Machine** section of the dialog box, change the inertia value to $10 \text{ kg} \cdot \text{m}^2$.
- 2 Click **OK** to apply the changes and close the dialog box.

Setting the Braking Chopper Resistance Value

The three-phase inverter of the DTC system is fed by a DC voltage produced by a three-phase diode rectifier. A capacitor located at the output of the rectifier reduces the DC bus voltage ripples. A braking chopper block has also been added between the rectifier block and the inverter block, in order to limit the DC bus voltage when the motor feeds back energy to the drive (shown below). This energy is “burned” through a resistance when the DC bus voltage is too high.

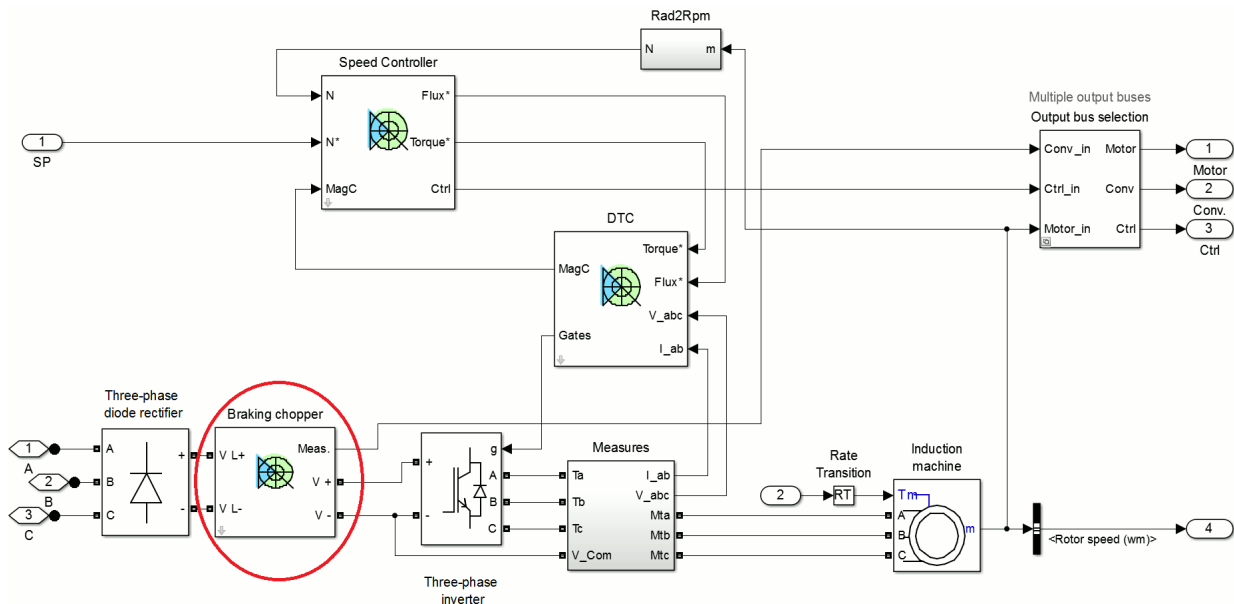

Braking Chopper

The parameters of the braking chopper are available in the **Converters and DC bus** section of the dialog box, as shown below:

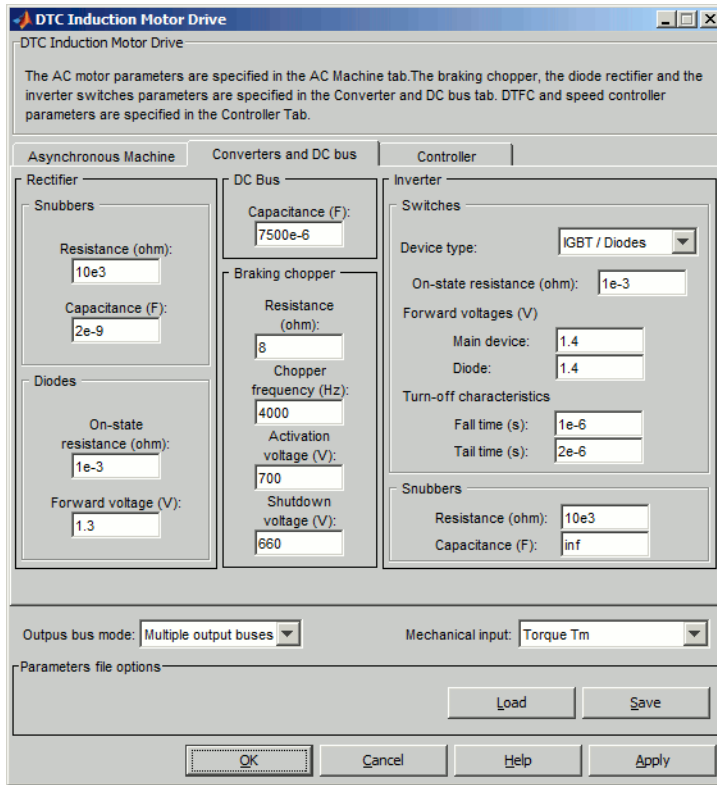

Converters and DC Bus Section of the User Interface

The braking chopper parameters are currently set to limit the DC bus voltage to about 700 V. Regarding the power P to be dissipated and the DC bus voltage limit V_{lim} , you can use the following equation to set the chopper resistance value:

$$R_{chop} = \frac{V_{lim}^2}{P}$$

A resistance of 3.3 Ω will dissipate 200 hp at 700 V.

Setting the DC Bus Initial Voltage Value

Notice that the DC bus capacitance has a large value to reduce DC voltage ripples to small values. The AC4 model does not include a DC bus capacitor preload system. If you

start the simulation with too small an initial bus voltage, too high initial currents are drawn from the rectifier to charge the capacitor. These high current values could damage a real-life system. You must set an initial DC bus voltage value to avoid such currents. This initial bus voltage must be equal to the rectified peak value of the AC source. If the AC voltage source amplitude is equal to 460 V, the rectified DC bus voltage obtained with a capacitor is about $460 \times \sqrt{2}$ V.

- 1 Double-click the Powergui block located at the top level of ac_example. Click the **Initial States Setting** button. Set the Uc_DTC Induction Motor Drive/Braking chopper/Cbus value to 650 V. Click **Apply** and then **Close**.

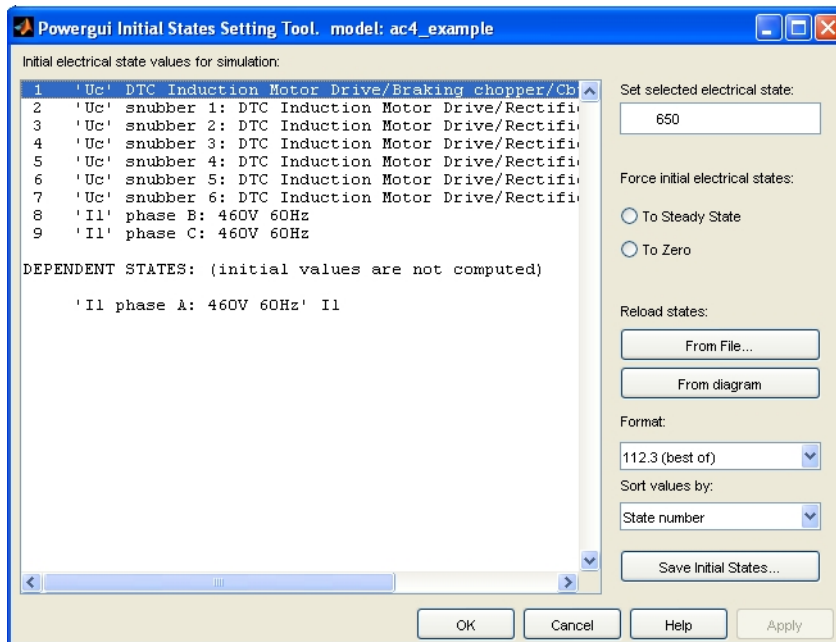

Setting the DC Bus Initial Voltage Value

Setting the AC4 Controller Parameters

The control system of AC4 has two main parts, a speed controller and a torque and flux controller (DTC). Information on these two parts is in the corresponding reference notes. For a quick idea of the internal structure of the drive control system, a schematic is

available inside the user interface of the model. Open the schematics related to the AC4 model.

- 1 Open the user interface. Click the **Controller** section and then the **Schematic** button. You should see the controller schematics shown.

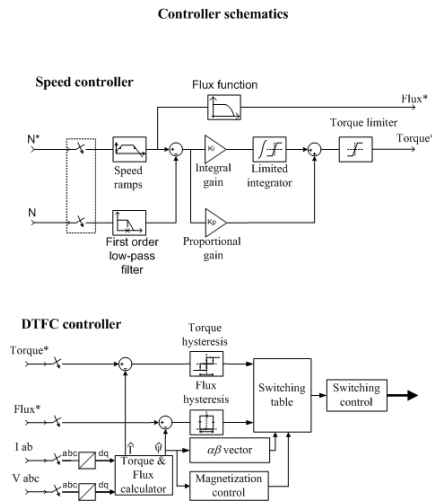

Controller Schematics of the User Interface

The speed controller consists of a simple proportional-integral regulator. The parameters of this controller are the proportional and integral gains, the speed ramp values, the low-pass filter cutoff frequency, the torque reference limits, and the sampling time. In this example, we will only control the motor torque; the speed controller is not used. Refer to “Setting the DC3 Controller Parameters and Simulation Results” on page 4-23 for more details on how to trim a PI controller.

Regarding the DTC controller, there is not much to trim. As you can see below, the parameters are the torque and flux bandwidths, the initial machine flux, the maximum switching frequency, and the DTC controller sampling time. All these parameters are already trimmed and should normally not be modified.

DTC Induction Motor Drive

The AC motor parameters are specified in the AC Machine tab. The braking chopper, the diode rectifier and the inverter switches parameters are specified in the Converter and DC bus tab. DTFC and speed controller parameters are specified in the Controller Tab.

Asynchronous Machine Converters and DC bus Controller

Regulation type: Torque regulation Schematic

Speed controller

Speed controller sampling time (s): 7*20e-6

Torque output limits (N-m)

Negative: -1200 Positive: 1200

DTC controller

Hysteresis bandwidth

Torque (N-m): 10	Flux (Wb): 0.02	Initial machine flux (Wb): 0.8	Maximum switching frequency (Hz): 20000	DTC sampling time (s): 20e-6
------------------	-----------------	--------------------------------	---	------------------------------

Output bus mode: Multiple output buses Mechanical input: Torque Tm

Parameters file options

Load Save

OK Cancel Help Apply

Controller Section of the User Interface

The default regulation mode is speed regulation. In order to have torque regulation, you must change the regulation mode in the **Controller** section of the user interface.

- 2 In the **Controller** section of the user interface, select **Torque regulation** for the **Regulation type** field. Click **OK** to apply the changes and close the dialog box.

The circuit is now ready for simulation.

Simulation Results

The simulation results are shown below.

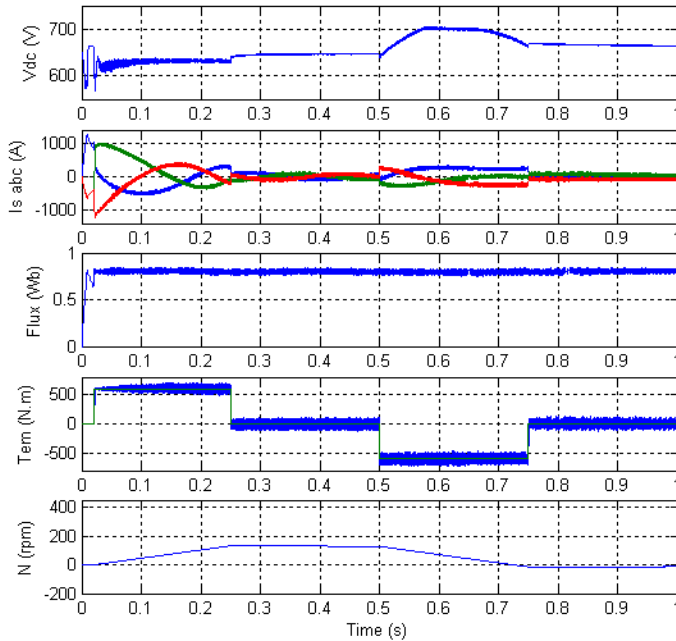

Simulation Results

Observe the motor's fast torque response to the torque set point changes. From 0.02 s to 0.25 s, the fan speed increases because of the 600 N.m acceleration torque produced by the induction motor. At $t = 0.25$ s, the electromagnetic torque jumps down to 0 N.m and the speed decreases because of the load torque opposed by the fan. At $t = 0.5$ s, the motor torque develops a -600 N.m torque and allows braking of the fan. During braking mode, power is sent back to the DC bus and the bus voltage increases. As planned, the braking chopper limits the DC bus voltage to 700 V. At $t = 0.75$ s, the electromagnetic torque jumps back to 0 N.m and the speed settles around -10 rpm and decreases toward 0 rpm. Notice that the flux stays around 0.8 Wb throughout the simulation. The flux and torque oscillation amplitudes are slightly higher than 0.02 Wb and 10 N.m respectively as specified in the user interface. This is due to the combined effects of the 15 μ s DTC controller sampling time, the hysteresis control, and the switching frequency limitation.

It is interesting to visualize the rotating flux produced by the stator. To do so, use a XY scope from the Sinks library.

- 1 Open the Sinks library.
- 2 Copy an XY scope inside the Signal Selector block of ac_example.
- 3 Connect the scope as shown.
- 4 Run a new simulation.

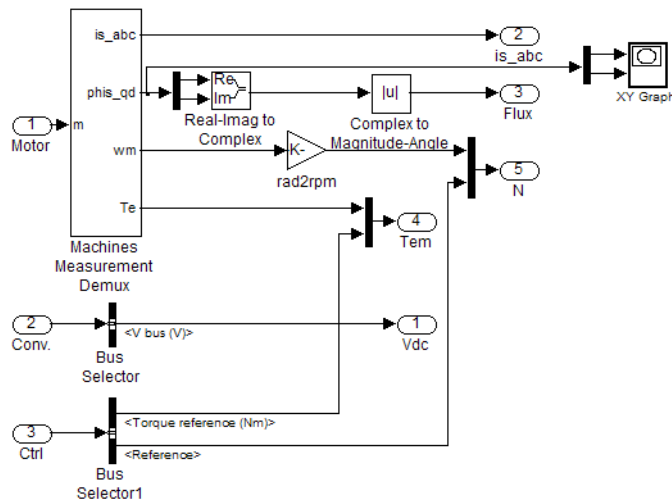

Adding a XY Graph to Visualize the Rotating Statoric Flux

The following figure shows the simulation results of the XY scope. The rotating field is clearly visible. Its modulus is about 0.8 Wb and its bandwidth is slightly bigger than 0.2 Wb.

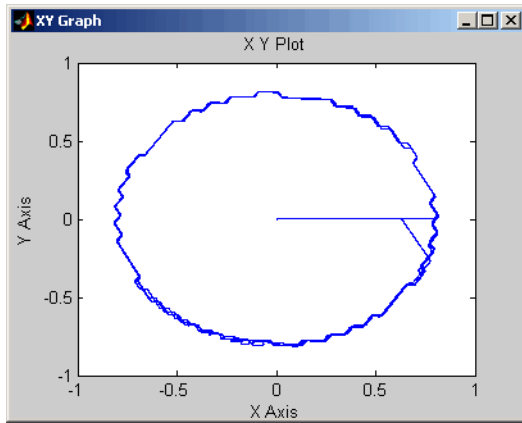

Rotating Stator Flux

Mechanical Models

In this section...

“Mechanical Shaft Block” on page 4-61

“Speed Reducer Block” on page 4-62

Mechanical Shaft Block

The **Mechanical Shaft** block is used to simulate a shaft interconnecting mechanically a motor drive block to a mechanical load block. Hence the **Mechanical Shaft** block allows decoupling of the mechanical parameters of the load from the ones of the motor. The mechanical shaft is represented by its stiffness coefficient K_{sh} and damping coefficient D_{sh} . The shaft transmitted torque T_{sh} is computed with

$$T_{sh} = K_{sh} \int (\omega_m - \omega_l) dt + D_{sh} (\omega_m - \omega_l)$$

where ω_m and ω_l are the speeds of the motor and the load, respectively.

The following figure shows the interconnections between the Motor Drive block, the **Mechanical Shaft** block, and the Mechanical Load block. The **Mechanical Shaft** block has two inputs, the load and motor speeds, and one output, the shaft transmitted torque. Note that the transmitted torque is applied at the load torque input of the motor. The transmitted torque is also applied at the input of the Mechanical Load block, which can be modeled by

$$T_{sh} = J_l \frac{d\omega_l}{dt} + B_l \cdot \omega_l$$

where J_l and B_l are the inertia coefficient and the viscous friction coefficient, respectively.

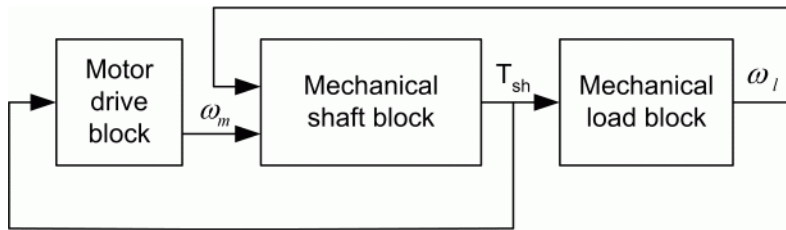

Interconnection Diagram of the Transmission Shaft

Speed Reducer Block

In many applications, the mechanical load requires high torque at low speed rather than low torque at high speed. This can be obtained by interconnecting the motor to the mechanical load by a speed reducer. The **Speed Reducer** block of the Electric Drives library is composed of a high-speed shaft and a low-speed shaft connected by a speed reduction device, as shown in the following figure. The **Speed Reducer** block has seven parameters: the stiffness and damping coefficients of the high-speed and the low-speed shafts, the reduction ratio, and the speed reduction device inertia and efficiency. The two inputs of the **Speed Reducer** block are the motor speed (high speed) and the load speed (low speed) while the outputs are the high-speed shaft torque T_h and the low-speed shaft torque T_l . The high-speed shaft torque must be applied to the load torque input of the motor. The low-speed shaft torque must be applied directly to the Mechanical Load block.

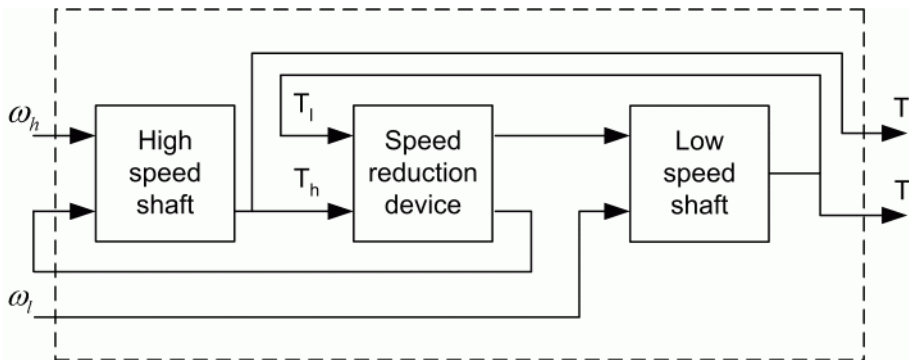

Interconnection Diagram of the Three Internal Blocks of the Speed Reducer Block

Mechanical Coupling of Two Motor Drives

In this section...

“Introduction” on page 4-63

“System Description” on page 4-64

“Speed Regulated AC4 with Torque Regulated DC2” on page 4-66

“Torque Regulated AC4 with Speed Regulated DC2” on page 4-68

Introduction

In order to test a motor drive under various load conditions, you must provide a variable and bidirectional load at the motor shaft. Moreover, an ideal load should also allow returning the absorbed energy from the motor back to the power grid as electric energy. Such a load can be implemented using a four-quadrant motor drive such as the DC2 or DC4 models. Either of these two motor drives can be conveniently coupled to the motor drive model being tested by the use of the mechanical shaft model.

Therefore this case study will consist of coupling the AC4 motor drive model to the DC2 motor drive. The AC4 motor drive is a DTC three-phase induction motor-based drive. The DC2 motor drive is a single-phase dual-converter DC motor drive. In such a system, one drive is speed regulated while the other is torque regulated, but each drive can operate either as a motor or as a generator, as will be seen later. The DC2 motor drive is rated 3 hp, 240 V, 1800 rpm, and the AC4 motor drive is rated 3 hp, 380 V, 60 Hz, 4 poles.

Note It is also possible to couple two motor drives using the **Mechanical input** menu located in the lower part of the GUI. The next figure indicates how to model a stiff shaft interconnection in a motor-generator configuration. The speed output of drive 1 (mechanical input is load torque) is connected to the speed input of drive 2 (mechanical input is motor speed), while drive 2 electromagnetic torque output T_e is applied to the mechanical torque input T_m of drive 1. The K_w factor represents the speed reduction ratio. Also, because inertia J_2 and viscous friction F_2 are ignored in the machine of drive 2, they have to be added in the machine tab of drive 1.

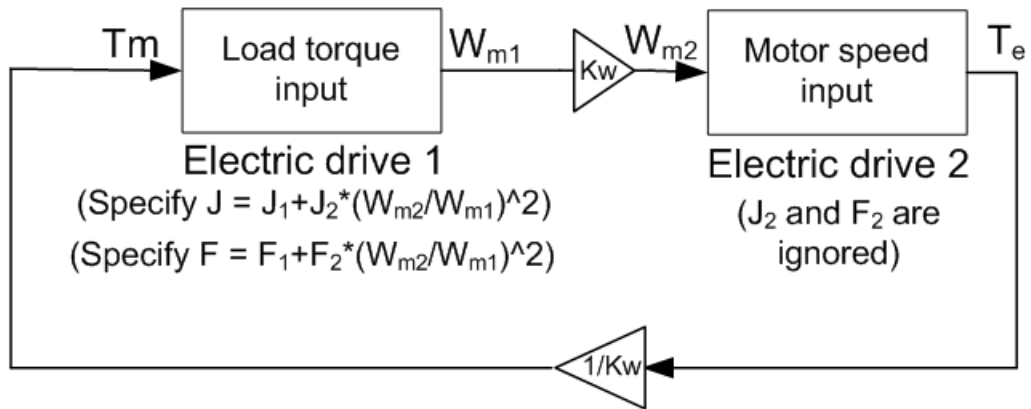

System Description

The complete system consisting of two motor drives mechanically coupled together is shown in SPS Diagram of the Two Interconnected Drives. The mechanical shaft model is contained in the third block of the diagram. If you open this block, you will see, as in Interconnections of the Mechanical Shaft Model, that the AC4 and DC2 motor speed signals are connected respectively to the Nm and Nl inputs of the mechanical shaft model. The output Tl of the mechanical shaft model represents the mechanical torque transmitted from the AC4 motor to the DC2 generator. Therefore, this output is connected directly to the mechanical torque input of AC4, and is also sign inverted and then connected to the mechanical torque input of DC2, as can be seen in SPS Diagram of the Two Interconnected Drives.

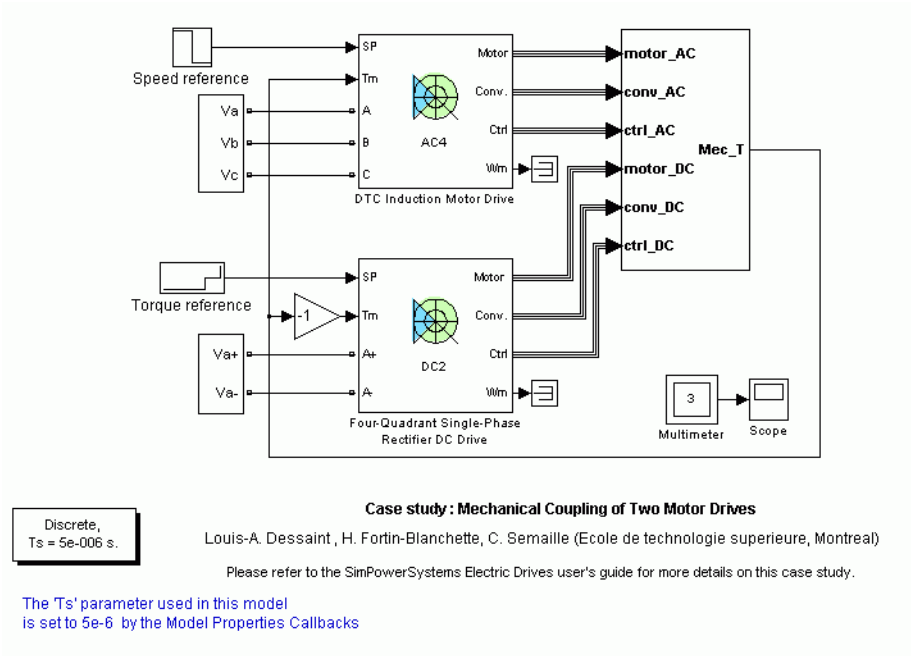

SPS Diagram of the Two Interconnected Drives

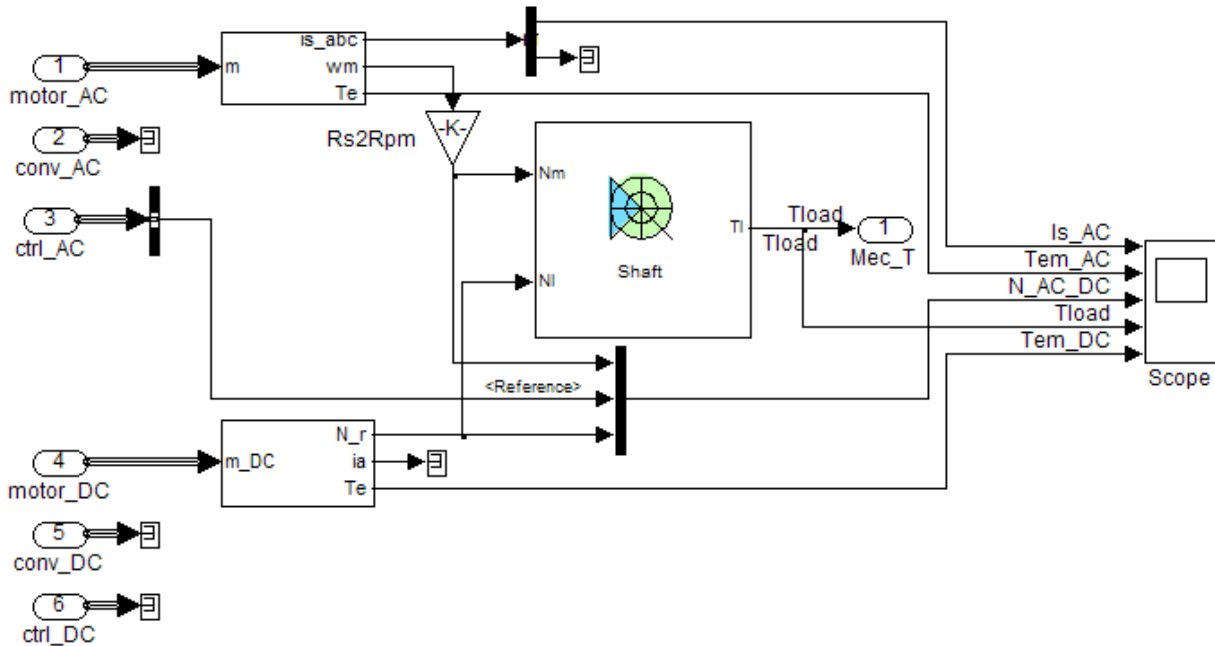

Interconnections of the Mechanical Shaft Model

Speed Regulated AC4 with Torque Regulated DC2

To begin with, the AC4 model operates as a speed regulated motor loaded by the DC2 model operating as a torque regulated generator. This setup, contained in the `cs_coupling_1` file, allows the testing of the AC4 model speed ramps and load torque disturbance responses. Note that in steady state, the signs of the AC4 electric torque and speed should be the same, confirming that AC4 operates as a motor. The DC2 electric torque and speed should be of opposite signs, confirming that DC2 operates as a generator. This is in line with the sign of the reference torque applied to the DC2 motor drive that is opposite to the speed sign.

Speed Ramp and Load Disturbance Torque Responses of the AC4 Motor Drive shows the results of an AC4 motor drive startup at nearly full load followed by the application of load disturbance torques. You can see that the AC4 motor speed is exactly superposed to

the reference ramp of +400 rpm/s since the AC4 electric torque maximum limit is high enough. The AC4 motor speed reaches the demanded value of 400 rpm at $t = 1.0$ s. At that moment, the AC4 electric torque drops down to 10 N.m. Then at $t = 1.4$ s, a reference torque of 0 N.m is applied to DC2; the AC4 electric torque immediately drops down to zero in order to maintain the regulated speed. At $t = 1.9$ s, a reference torque of +10 N.m is applied to the DC2 drive, forcing AC4 to operate as a generator and DC2 as a motor (look at the speed and torque signs of the two drives). Finally, a negative reference speed ramp of -400 rpm/s is applied to AC4 at $t = 2.3$ s. Note that, again, AC4 precisely follows the demanded ramp. A new steady state is reached at $t = 2.8$ s, and the AC4 electric torque stabilizes at -10 N.m. Speed Ramp and Load Disturbance Torque Responses of the AC4 Motor Drive also shows the mechanical torque transmitted by the shaft, which is similar to the AC4 electric torque but contains less ripple.

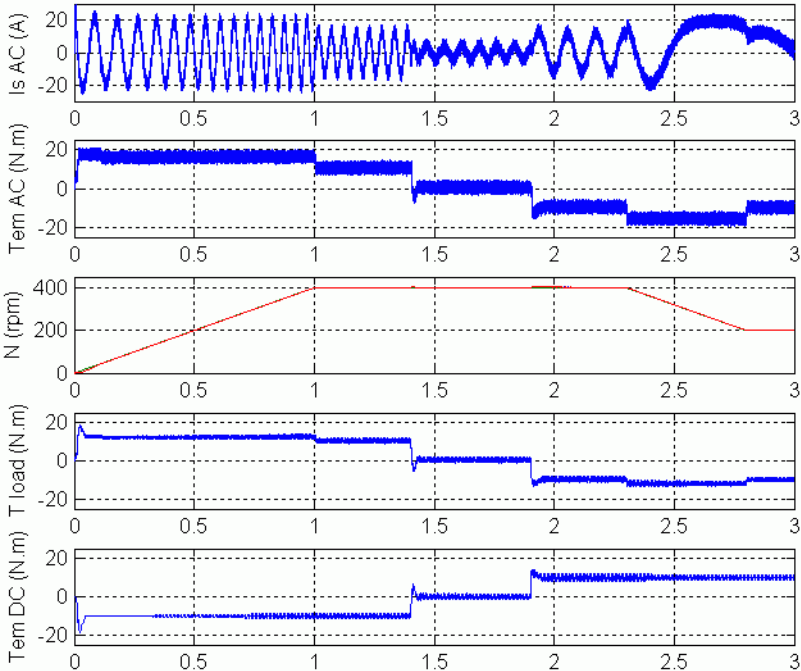

Speed Ramp and Load Disturbance Torque Responses of the AC4 Motor Drive

Torque Regulated AC4 with Speed Regulated DC2

This time, AC4 operates as a torque regulated motor loaded by the DC2 drive that is speed regulated. The complete system is shown in SPS Diagram of the Two Interconnected Drives and is contained in the `cs_coupling_2` file. The interconnection of the mechanical shaft model with the two drives remains unchanged with respect to Interconnections of the Mechanical Shaft Model. All the regulator gains of both drives are the same as in the previous case. The setup is tested in the same conditions as before.

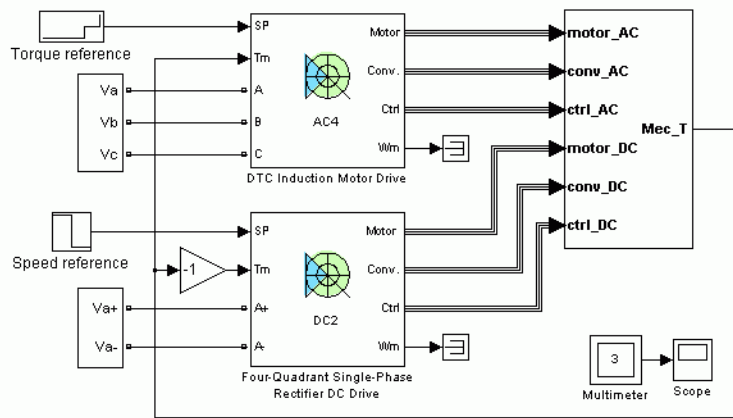

Case study: Mechanical Coupling of Two Motor Drives

Louis-A. Dessaint, H. Fortin-Blanchette, C. Semaille (Ecole de technologie superieure, Montreal)

Please refer to the SimPowerSystems Electric Drives user's guide for more details on this case study.

Discrete,
Ts = 5e-006 s.

The 'Ts' parameter used in this model is set to 5e-6 by the Model Properties Callbacks

SPS Diagram of the Two Interconnected Drives

Speed Ramp and Load Disturbance Torque Responses of the DC2 Motor Drive shows the results of a DC2 motor drive startup at nearly full load followed by the application of load disturbance torques. Note that the DC2 motor speed follows the reference ramp of 400 rpm/s with some overshoot and undershoot. The DC2 motor speed reaches the demanded value of 400 rpm at $t = 1.0$ s and stabilizes completely at $t = 1.2$ s. Then at $t = 1.4$ s, a reference torque of 0 N.m is applied to AC4; observe how fast the AC4 torque responds. At $t = 1.9$ s, a reference torque of +10 N.m is applied to the AC4 drive, forcing DC2 to operate as a generator and AC4 as a motor (look at the speed and torque signs of the two drives). Observe that the DC2 speed overshoots each time the load torque changes.

Finally, a negative reference speed ramp of -400 rpm/s is applied to DC2 at $t = 2.3$ s. The DC2 speed follows well but presents a small overshoot and a small undershoot. A new steady state is reached at $t = 2.8$ s, and the DC2 electric torque stabilizes at -10 N.m. Speed Ramp and Load Disturbance Torque Responses of the DC2 Motor Drive also shows the mechanical torque transmitted by the shaft, which is very similar to the negative of the DC2 electric torque but with more ripple.

You can see from the results shown in Speed Ramp and Load Disturbance Torque Responses of the AC4 Motor Drive and Speed Ramp and Load Disturbance Torque Responses of the DC2 Motor Drive that the speed ramp responses are more precise and the load torque disturbance more efficiently rejected with the AC4 drive than with the DC2 drive. This is essentially due to the fast dynamics of the AC4 electric torque. Recall that the AC4 drive consists of a direct torque controller based on hysteresis comparators and high-frequency switching, while the DC2 drive relies entirely on naturally commutated thyristor converters. However, the torque ripple magnitude of the AC4 drive is higher than for the DC2 drive.

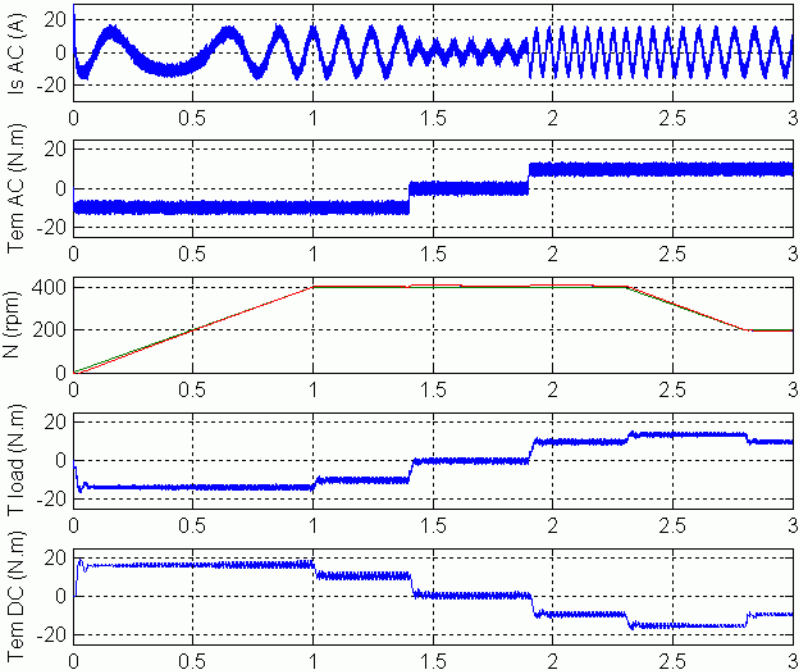

Speed Ramp and Load Disturbance Torque Responses of the DC2 Motor Drive

Winding Machine

In this section...
“Introduction” on page 4-70
“Description of the Winder” on page 4-70
“Block Description” on page 4-72
“Simulation Results” on page 4-74

Introduction

Winding machines, also called winders, are used in the pulp and paper industry as well as in the textile, steel, and plastic industries.

An important characteristic of most winders is that the force acting on the winding material must remain constant. This is realized by controlling the winder torque proportionally to the roll variable radius. Note that it is assumed here that the material is fed to the winder at constant speed. The latter implies that the winder angular speed is forced to decrease proportionally to the roll radius. Hence the winding machine is a constant power application, because the product of the winder mechanical torque and its angular speed is constant.

Description of the Winder

The following graphic shows a physical representation of a winder, where W is the roll width, r_1 the core radius, r_2 the roll radius, and MT the material thickness.

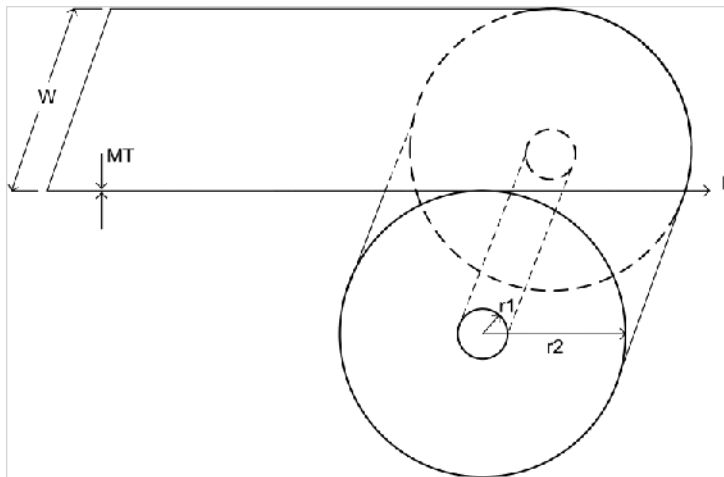

Physical Representation of a Winder

Beside the variables described above, the simulation also requires the following parameters and variables:

MV	Material mass per unit volume
L	Material length
M	Material mass
J_r	Material inertia
J_c	Winder core inertia
B_ω	Winder viscous friction coefficient

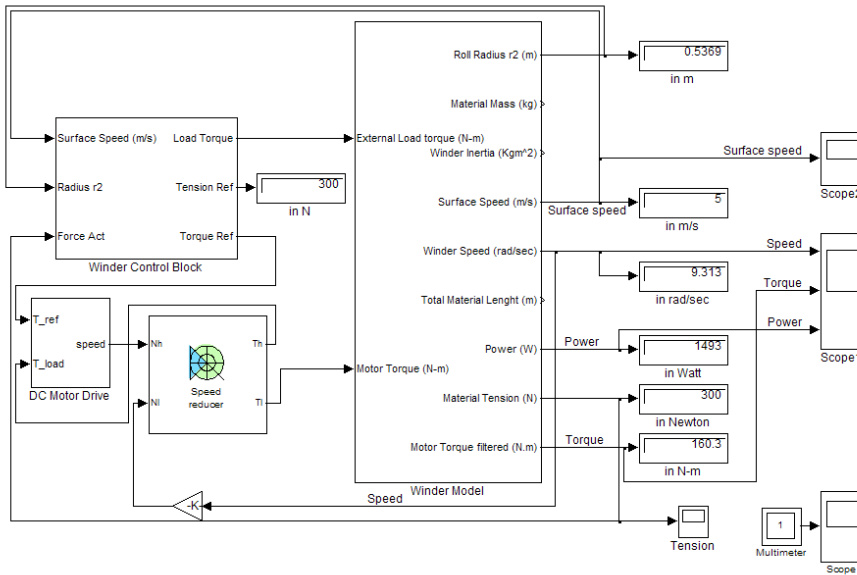

Case study : Winding Machine

Louis-A. Dessaint , H. Fortin-Blanchette, C. Semaille (Ecole de technologie superieure, Montreal)

Please refer to the SimPowerSystems Electric Drives user's guide for more details on this case study.

Discrete,
Ts = 1e-006 s.

Diagram of the Complete Winding System

Diagram of the Complete Winding System shows a Simulink diagram of the complete winding system. This system consists of four blocks: the Winder Control block, the DC Motor Drive block, the Speed Reducer block, and the Winder Model block.

Block Description

Winder Model Block

This block computes various winder variables using the following equations.

Surface speed S

$$S = \omega \cdot r_2$$

where ω is the winder angular speed.

Material length L

$$L = \int S dt$$

Roll radius r_2

$$r_2 = \sqrt{\frac{L \cdot MT}{\pi} + r_1^2}$$

Material mass M

$$M = MV \cdot \pi \cdot W \cdot (r_2^2 - r_1^2)$$

Total winder inertia J_t and material inertia J_ω

$$J_t = J_\omega + J_c$$

where

$$J_\omega = \frac{1}{2} \cdot M \cdot (r_2^2 + r_1^2)$$

The winder angular speed is calculated using the following differential equation

$$T_e = J_t \frac{d\omega}{dt} + B \cdot \omega + T_l$$

where T_l is the winder load torque and T_e is the motor drive electric torque. The calculation of the tension or force F applied on the winding material is based on the same differential equation as above, where the load torque is expressed as $T_l = F r_2$. Rearranging the equations in term of F yields

$$F = \frac{T_e - (J_t \cdot \dot{\omega}) - (B \cdot \omega)}{r_2}$$

This estimated force is fed back to the Winder Control block in order to be regulated.

Note that in the above two equations, the term $\omega \cdot \dot{J}_t$ is omitted because it has been found to be negligible for the case considered here.

Winder Control Block

This block contains a PID controller that regulates the tension applied on the winding material. The output of this force controller is a torque reference set point for the winder motor drive. The Winder Control block shown in Winder Control Block also contains the tension versus speed characteristic of the external process supplying the material to the winder at constant speed. This characteristic consists in a straight line of slope equal to the ratio of the reference material tension on the constant surface speed.

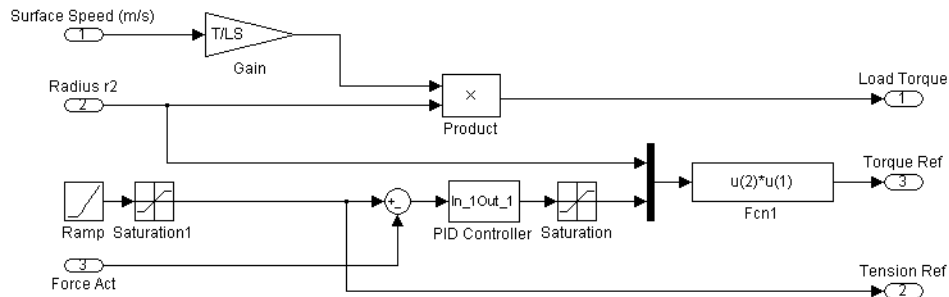

Winder Control Block

DC Motor Drive Block

This block contains a complete two-quadrant three-phase rectifier DC drive with its three-phase voltage source. The DC drive is rated 5 hp, 220 V, 50 Hz and is torque regulated.

Speed Reducer Block

The DC motor is connected to the winder by a **Speed Reducer** block. The speed reduction ratio is 10, allowing the winder to turn 10 times slower than the motor, while the shaft-transmitted torque is almost 10 times higher on the low-speed side. The torque required by the winder in this case study is approximately 200 N.m.

Simulation Results

The winding machine simulation model is contained in the file `cs_winder`. The simulation parameters are those of a paper winding application where the roll width

is 10 m. Open the file and look at the parameters in the Simulink masks of the Winder Model block, the Winder Control block, the DC Motor Drive block, and the Speed Reducer block. In the Winder Control block, you will see that the tension set point is 300 N and the surface speed set point is 5 m/s.

The rate of change of the tension set point is limited internally to 25 N/s so that the tension set point requires 12 s to reach its final value. Note that the simulation time step of the complete model is 1 μ s in order to comply with the speed reducer, which is the block that requires the smallest simulation time step.

Start the simulation and observe how well the material tension and the surface speed ramp to their prescribed values in Material Tension and Surface Speed respectively. Winder Angular Speed, Mechanical Torque, and Power shows the winder angular speed, mechanical torque, and power. Note that once the operating point is reached (300 N, 5 m/s), the angular speed decreases and the torque increases, both linearly, so that the power is approximately constant. The reason why the mechanical power is not precisely constant but decreases slightly is that the decreasing speed winder own inertia supplies a small part of the constant power required by the winder.

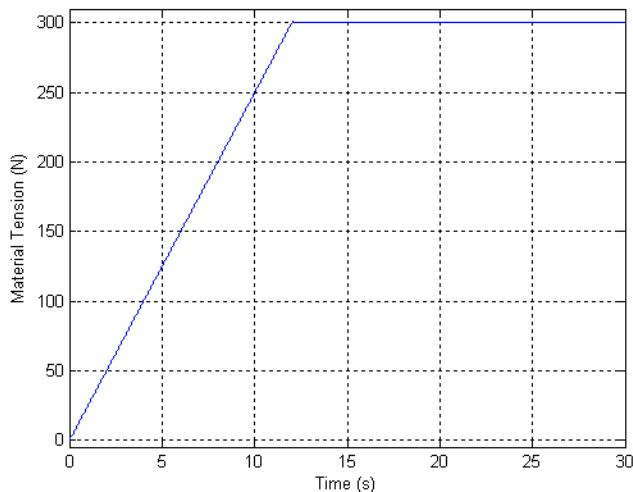

Material Tension

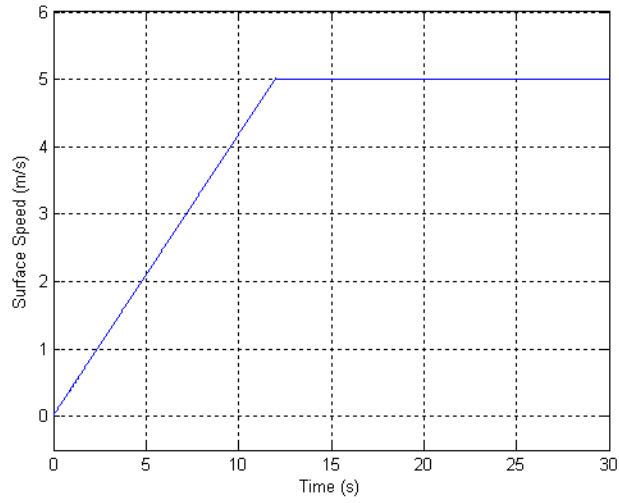

Surface Speed

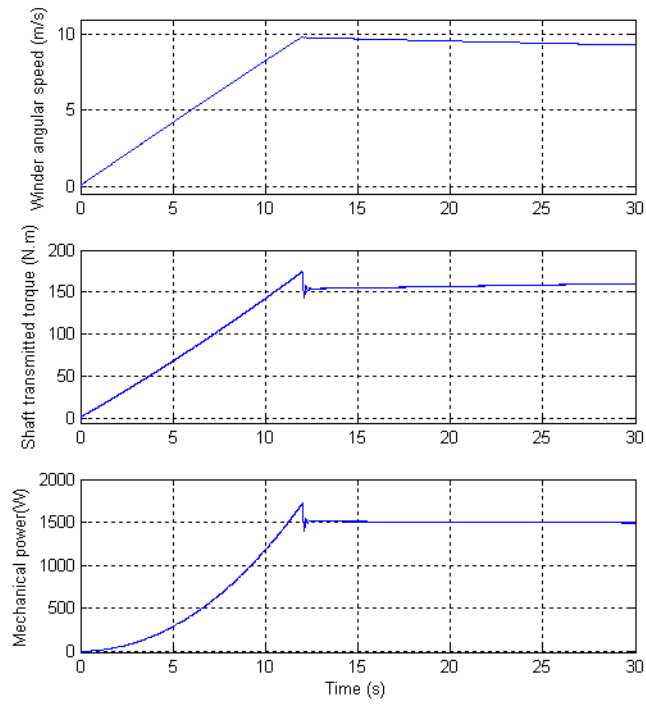

Winder Angular Speed, Mechanical Torque, and Power

Robot Axis Control Using Brushless DC Motor Drive

In this section...
“Introduction” on page 4-78
“Description of the Robot Manipulator” on page 4-78
“Position Control Systems for Joints 1 and 2” on page 4-79
“Modeling the Robot Position Control Systems” on page 4-80
“Tracking Performance of the Motor Drives” on page 4-84

Introduction

Robots are complex electromechanical systems where several electric drives are used to control the movement of articulated structures. The design of axis control systems for robots can be greatly facilitated by the Electric Drives library, which can model complete axes including motor drives, speed reducers, mechanical model of the arm, and controllers in the same diagram.

This case study presents the modeling and simulation of a six-degrees-of-freedom robot manipulator using Electric Drives library blocks in combination with Simulink blocks. The two main joints models are built using brushless DC motor drives that are connected to the rest of the manipulator through speed reducers (a model included in the Electric Drives library). The control system, which consists essentially of two position control loops, is built with Simulink blocks. The inner speed and torque control loops are already included in the drive model. The rest of the manipulator and its load are represented by two Simulink nonlinear models, one for each motor drive.

Detailed modeling is presented to demonstrate the versatility of the Electric Drives library. The operation of the joints using typical trajectories is simulated and results are presented.

Description of the Robot Manipulator

The robot considered in this example is a general-purpose six-degrees-of-freedom robot manipulator (GMF S-360) of parallelogram linkage type. Six-Degrees-of-Freedom Robot Manipulator shows the structure of the robot and its workspace. The robot has six axes. The three axes (Θ_1 , Θ_2 , Θ_3) shown in the figure are for arm positioning and the others (α ,

β, γ) are for orientation of the end effector. In the horizontal plane, the robot can cover a 300 degree arc ($\Theta_1 = -150^\circ$ to $\Theta_1 = 150^\circ$).

The robot's axes are driven by brushless DC motors that are modeled by permanent-magnet synchronous motors fed by PWM inverters (AC6 drive model). Speed reducers of belt type and gearbox are used to transmit torque from the motors to the joints.

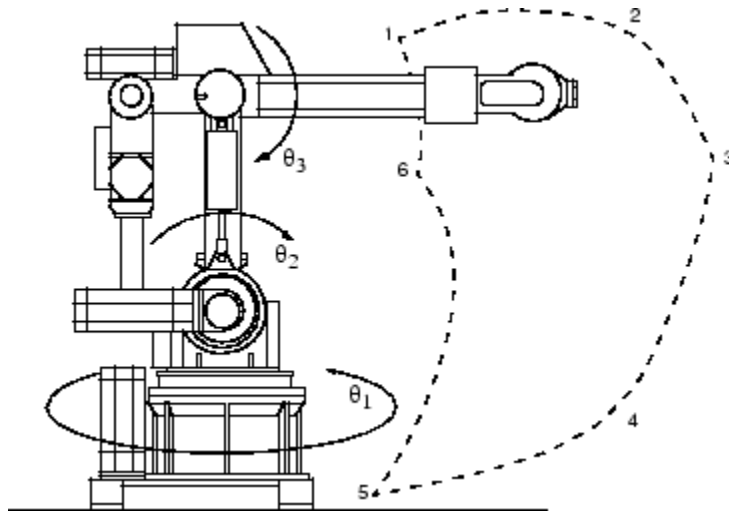

Six-Degrees-of-Freedom Robot Manipulator

Position Control Systems for Joints 1 and 2

We will consider in particular the two first joints, which drive the entire robot and its load. The first axis uses a 2 kW brushless DC motor and a 1:130 speed reducer. The second axis uses a 1 kW brushless DC motor and a 1:100 speed reducer. Brushless DC Motor Drive for Position Control of Robot Joint shows a simplified diagram of the position control system for one robot link.

The control system consists of three control loops connected in a cascade configuration: an outer position loop includes an inner speed control loop and an innermost current control loop. The PM synchronous motor is fed by a three-phase PWM inverter operating in current-controlled mode. Field-orientation scheme is used to decouple the variables so that flux and torque can be separately controlled by stator direct-axis current i_{ds} and

quadrature-axis current i_{qs} , respectively. The quadrature-axis current reference i_{qs}^* (which represents the torque command) is provided by the speed control loop. The direct-axis current reference i_{ds}^* is kept equal to 0.

A speed/position sensor is used to provide the information required by the speed and position control loops. The rotor position is also required for coordinates conversion (dq to abc).

Each motor drives the rest of the robot structure, including the other links and the load, through a speed reducer.

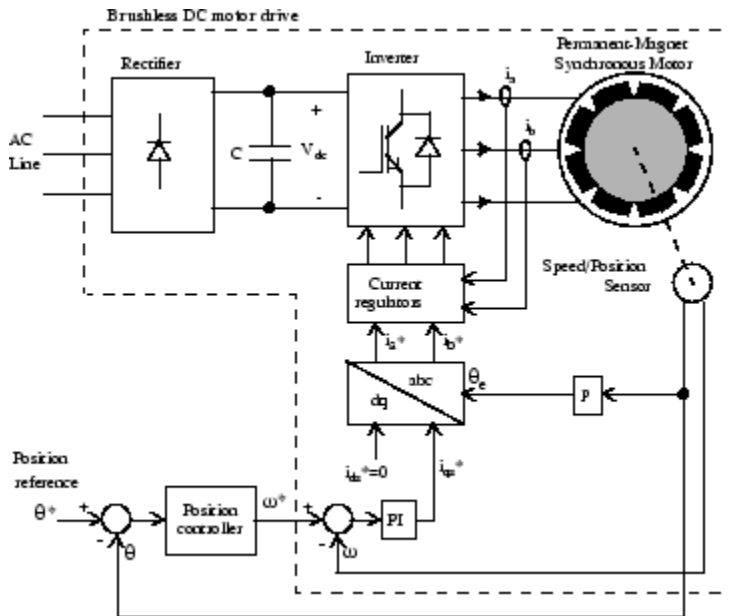

Brushless DC Motor Drive for Position Control of Robot Joint

Modeling the Robot Position Control Systems

The entire drive system for the robot's two first joints, including motor drives, speed reducers, equivalent loads, and controllers can be modeled in the same diagram using blocks from the Electric Drives library and Simulink libraries, as shown in Diagram Representing the Robot's Main Axes Drive Systems.

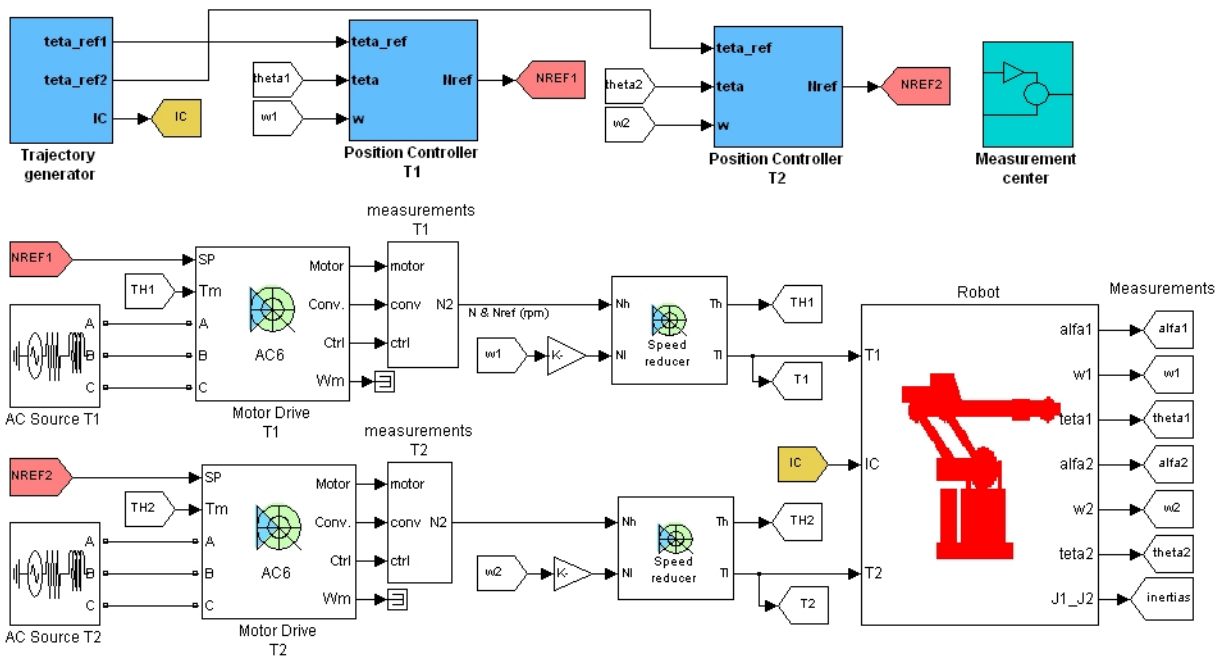

Diagram Representing the Robot's Main Axes Drive Systems

The brushless DC motor drives are represented by two AC6 (PM Synchronous Motor Drive) blocks from the Electric Drives library. This block models a complete brushless DC motor drive including a permanent-magnet synchronous motor (PMSM), an IGBT inverter, speed controller, and current controller. The AC6 inputs are the speed commands and the outputs are the motor speed, which are fed to the inputs of the speed reducers.

The speed reducers are modeled by two Speed Reducer blocks from the Electric Drives library. The inputs for these blocks are the motors' speeds, and the outputs are the torques from the low-speed sides, which are applied to the robot structure model. The speed reducers are characterized by their ratio and inertia and the stiffness and damping of input and output shafts.

The speed reducers' output shafts are connected to the T_1 and T_2 inputs of a Robot block that represents the rest of the robot structure. This block calculates the effective torque reflected to each joint. For each joint (numbered i), we can consider globally the other

links effects as a single load reflecting to the joint a torque that is composed of three terms

$$T_L = J_i \frac{d^2\theta_i}{dt^2} + C_i \frac{d\theta_i}{dt} + G_i \cdot \theta_i$$

where Θ_i is joint angular position, J_i is inertia, C_i is centrifugal and Coriolis coefficient, and G_i is gravitational coefficient.

The Robot model is built with Simulink blocks.

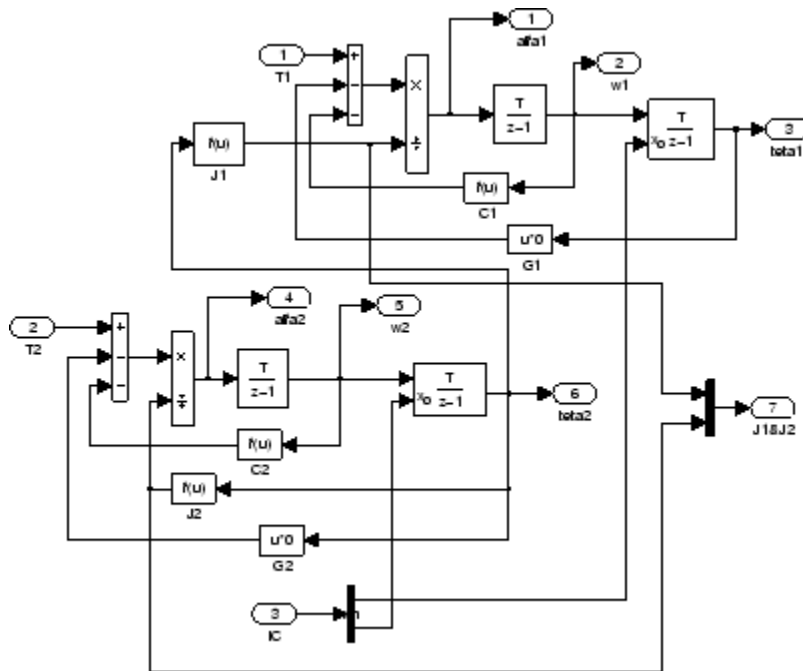

In this diagram, the parameters J_1 , C_1 , G_1 , J_2 , C_2 , and G_2 are functions of joint positions. Implement them by using polynomials or lookup tables.

The joint positions Θ_1 and Θ_2 are controlled by outer control loops that force Θ_1 and Θ_2 to follow the references imposed by the trajectories of the manipulator. Various algorithms can be used for these control loops. The most popular ones are proportional-derivative, computed torque, and adaptive. In this example, proportional-derivative controllers are implemented for both axes.

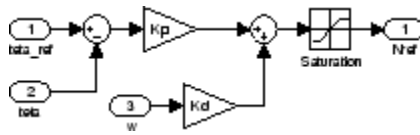

Cubic polynomial test trajectories for robot motion are generated by the Trajectory Generator block.

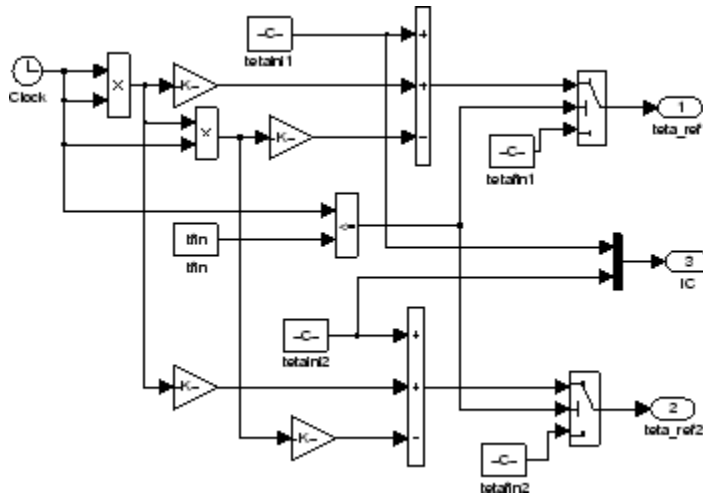

The test trajectories consist of a movement from position 6 to position 3 in the workspace (θ_2 varying from $-\pi/4$ to $\pi/4$) while rotating around axis 1 from one position to another (θ_1 varying from $-\pi/6$ to $\pi/6$). The parameters to be specified for this block are initial position $[\theta_{1ini}, \theta_{2ini}]$, final position $[\theta_{1fin}, \theta_{2fin}]$, and move time. The following figure shows the changes of robot structure during the programmed movement.

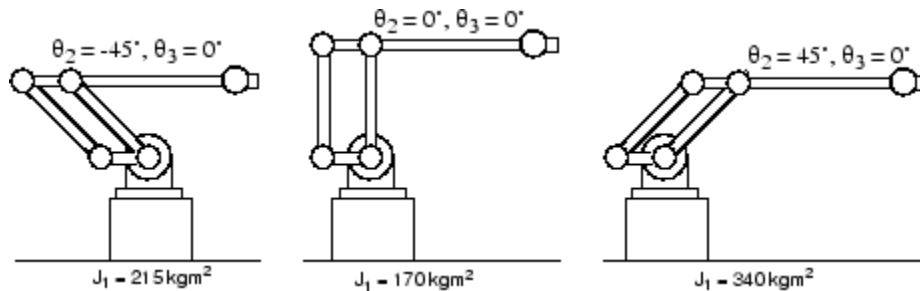

The variation of inertia due to structure changes is reflected to axis 1 as an inertia varying as a function of Θ_2 (from 215 kgm^2 to 340 kgm^2 passing by a minimum of 170 kgm^2). The inertia reflected to axis 2 is a constant ($J_2 = 50 \text{ kgm}^2$). These inertia variations are represented by nonlinear functions implemented in the Robot block.

Tracking Performance of the Motor Drives

The test trajectories described above constitute one of the most demanding trajectories for the motor drive of the first and second joints. They are used here to evaluate the tracking performance of the two electric drive systems.

In the simulation, the manipulator is programmed to rotate from -30° to 30° during 1.5 seconds, and at the same time the arm is moved from the back position ($\Theta_2 = -45^\circ$) to the most advanced position ($\Theta_2 = 45^\circ$). The simulation is run using a time step of $1 \mu\text{s}$.

The responses of the manipulator and the motor drives 1 and 2 are displayed on three scopes connected to the output variables of the AC6 and Robot blocks. The results are shown in Responses of the Manipulator's Joints 1 and 2 During a Test Trajectory, Responses of the Brushless DC Motor Drive of Axis No. 1 During Test Trajectory, and Responses of the Brushless DC Motor Drive of Axis No. 2 During Test Trajectory.

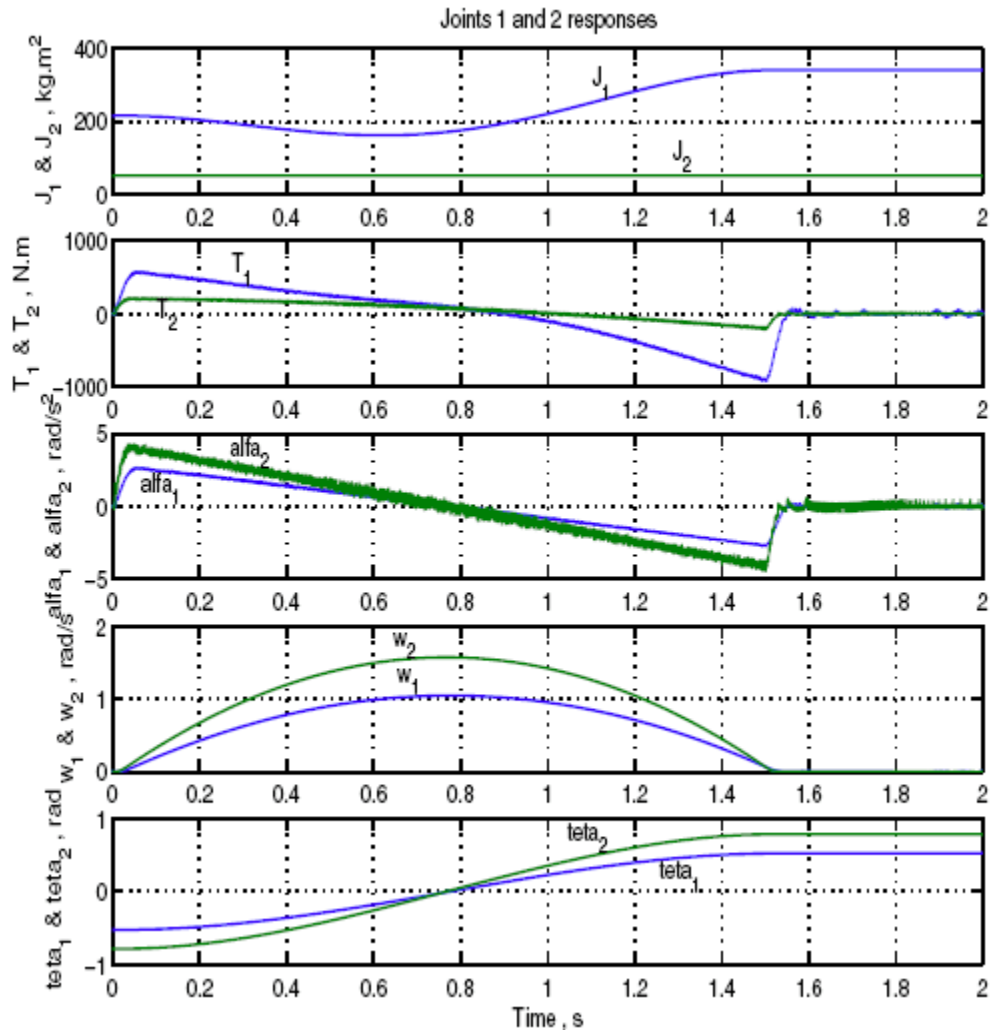

Responses of the Manipulator's Joints 1 and 2 During a Test Trajectory

During the movement, the joint positions Θ_1 and Θ_2 follow the imposed cubic trajectories with low tracking error. The shapes of the speeds and accelerations are in very good agreement with theoretical predictions. The speed variations are second-degree curves and the accelerations are almost linear curves.

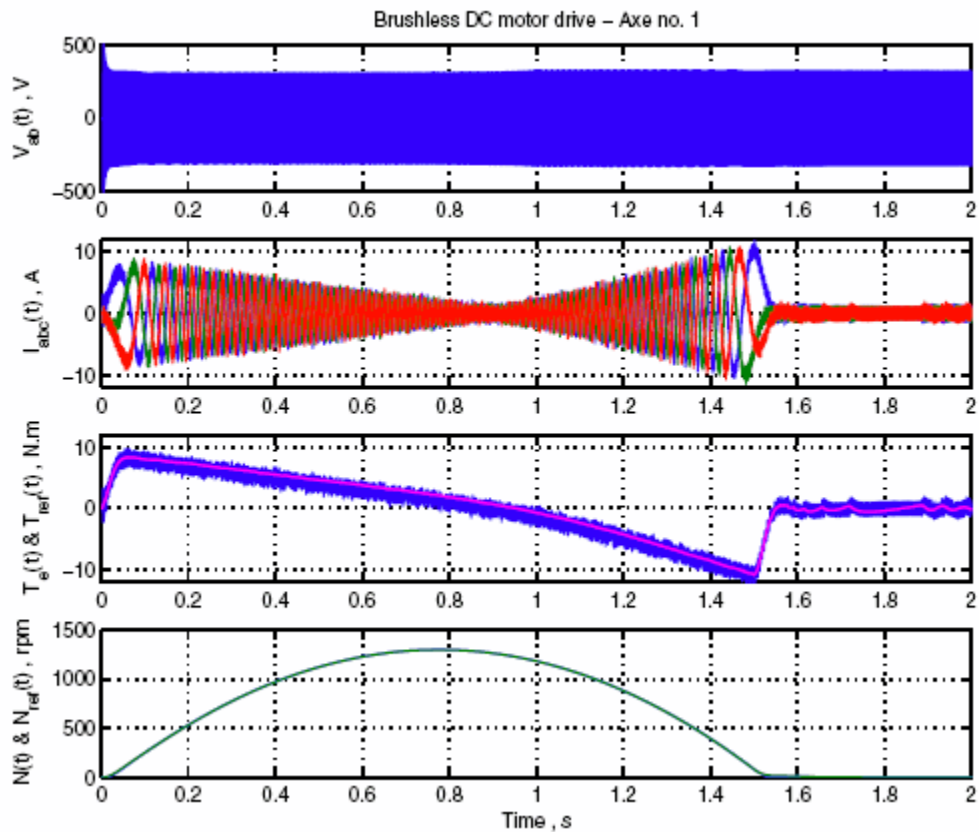

Responses of the Brushless DC Motor Drive of Axis No. 1 During Test Trajectory

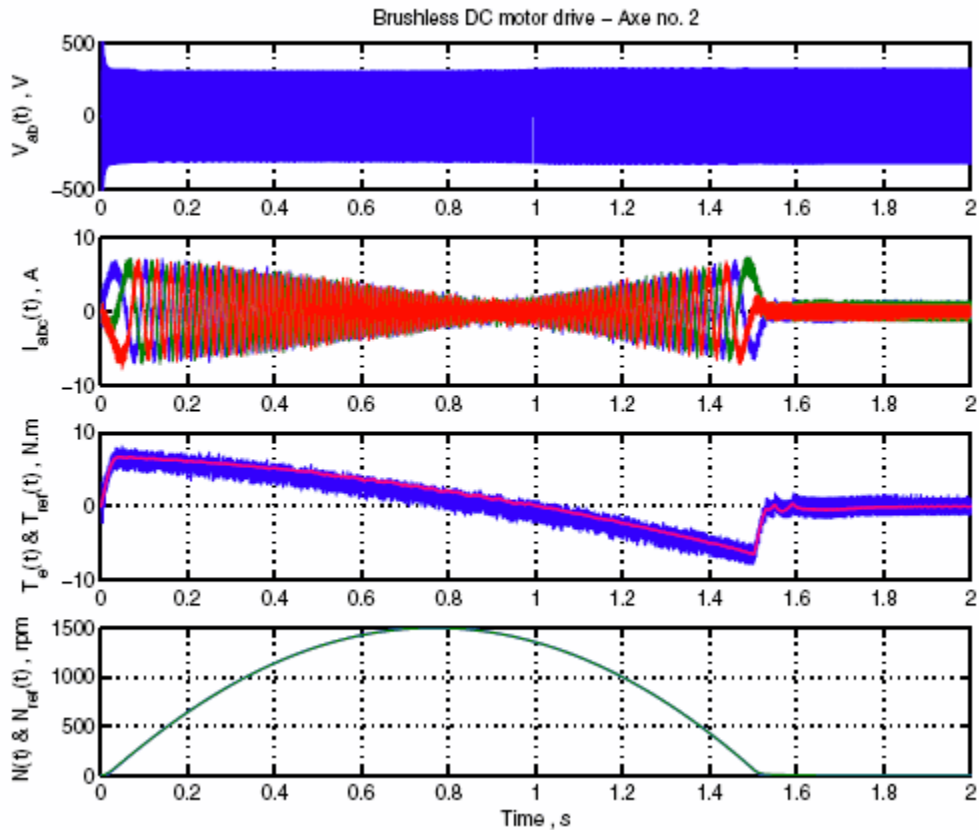

Responses of the Brushless DC Motor Drive of Axis No. 2 During Test Trajectory

The brushless DC motor drives behave very well during the test trajectories. The DC bus voltages are maintained at relatively constant levels during the deceleration of the motors. The developed torques are proportional to the motor currents' amplitudes. This demonstrates the good operation of the field-oriented control algorithms. As can be noted on the waveforms, the motor speeds track their reference profiles with very small errors.

References

- [1] Miller, T. J. E., *Brushless Permanent-Magnet and Reluctance Motor Drives*, Clarendon Press, Oxford, 1989.

- [2] Spong, M. W., and Vidyasagar, M., *Robot Dynamics and Control*, John Wiley & Sons, New York, 1989.

Building Your Own Drive

In this section...

“Introduction” on page 4-89

“Description of the Drive” on page 4-90

“Modeling the Induction Motor Drive” on page 4-92

“Simulating the Induction Motor Drive” on page 4-96

“Starting the Drive” on page 4-97

“Steady-State Voltage and Current Waveforms” on page 4-97

“Speed Regulation Dynamic Performance” on page 4-98

Introduction

Although the Electric Drives library contains models of motor drives widely used in the industry, you might have some specific requirements leading you to build your own motor drive model. The following information describes how to build a motor drive model using Simulink and SimPowerSystems blocks. You will build the field-oriented-control motor drive, very similar to the AC3 model of the electric drive library. The following figure shows the block diagram of the drive.

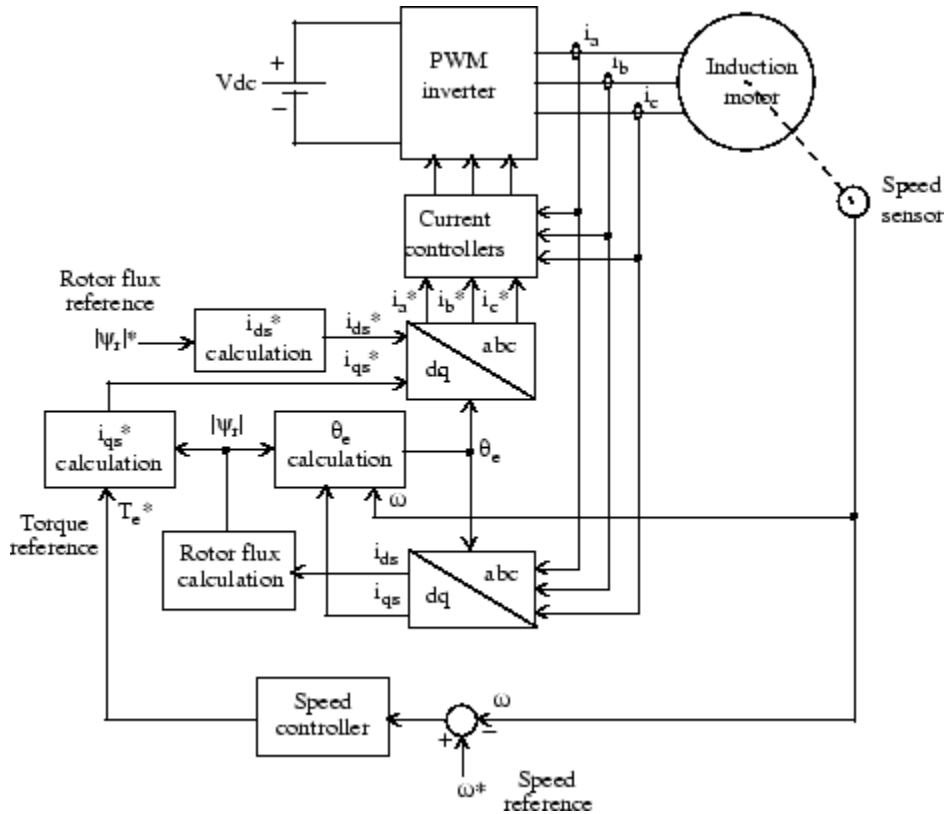

Field-Oriented Variable-Frequency Induction Motor Drive

Description of the Drive

The induction motor is fed by a current-controlled PWM inverter, which operates as a three-phase sinusoidal current source. The motor speed ω is compared to the reference ω^* and the error is processed by the speed controller to produce a torque command T_e^* .

As shown below, the rotor flux and torque can be separately controlled by the stator direct-axis current i_{ds} and quadrature-axis current i_{qs} , respectively.

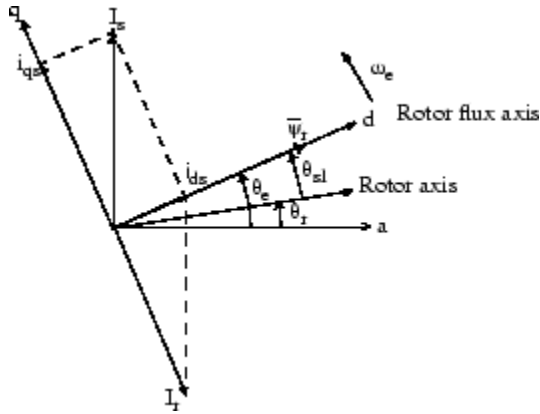

Field-Oriented Control Principle

The mathematical principles of this AC drive have been discussed in “Electric Drives Library” on page 4-2. Here, we will only rewrite the basic equations. The stator quadrature-axis current reference i_{qs}^* is calculated from torque reference T_e^* as

$$i_{qs}^* = \frac{2}{3} \cdot \frac{2}{p} \cdot \frac{L_r}{L_m} \cdot \frac{T_e^*}{|\psi_r|_{est}}$$

where L_r is the rotor inductance, L_m is the mutual inductance, and $|\psi_r|_{est}$ is the estimated rotor flux linkage given by

$$|\psi_r|_{est} = \frac{L_m \cdot i_{ds}}{1 + \tau_r \cdot s}$$

where $\tau_r = L_r / R_r$ is the rotor time constant.

The stator direct-axis current reference i_{ds}^* is obtained from rotor flux reference input $|\psi_r|^*$.

$$i_{ds}^* = \frac{|\psi_r|^*}{L_m}$$

The rotor flux position Θ_e required for coordinates transformation is generated from the rotor speed ω_m and slip frequency ω_{sl} .

$$\theta_e = \int (\omega_m + \omega_{sl}) dt$$

The slip frequency is calculated from the stator reference current i_{qs}^* and the motor parameters.

$$\omega_{sl} = \frac{L_m}{|\psi_r|_{est}} \cdot \frac{R_r}{L_r} \cdot i_{qs}^*$$

The i_{qs}^* and i_{ds}^* current references are converted into phase current references i_a^* , i_b^* , i_c^* for the current regulators. The regulators process the measured and reference currents to produce the inverter gating signals.

The role of the speed controller is to keep the motor speed equal to the speed reference input in steady state and to provide a good dynamic during transients. The controller can be a proportional-integral type.

Modeling the Induction Motor Drive

Open the `power_acdrive` model and save it as `case3` in your working directory so that you can make further modifications without altering the original file.

The next figure shows the `power_acdrive` model in which blocks from SimPowerSystems and Simulink libraries are used to model the induction motor drive.

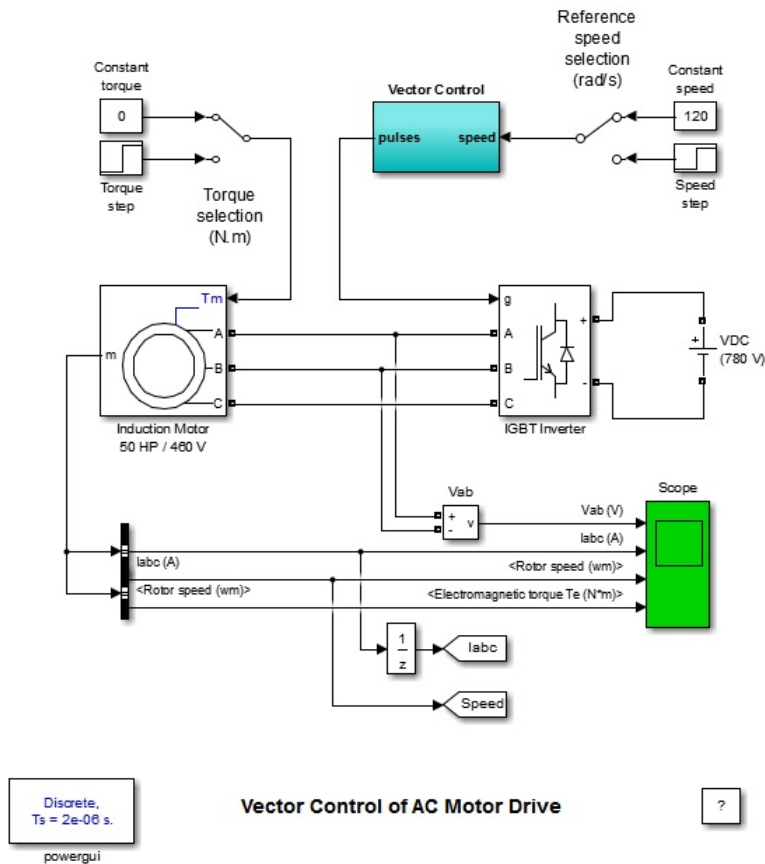

Vector Control of AC Motor Drive (power_acdrive)

The induction motor is modeled by an **Asynchronous Machine** block. The motor used in this case study is a 50 HP, 460 V, four-pole, 60 Hz motor having the following parameters:

R_s	0.087 Ω
L_{ls}	0.8 mH
L_m	34.7 mH
R_r	0.228 Ω

Llr	0.8 mH
------------	---------------

The reference speed and the load torque applied to the motor shaft can be both selected by a Manual Switch block in order to use either a constant value or a step function. Initially the reference speed is set to a constant value of 120 rad/s and the load torque is also maintained constant at 0 N.m

The field-oriented control is modeled by the Vector Control block, as shown in Vector Control of AC Motor Drive (power_acdrive). This block consists of Simulink blocks shown in the following figure.

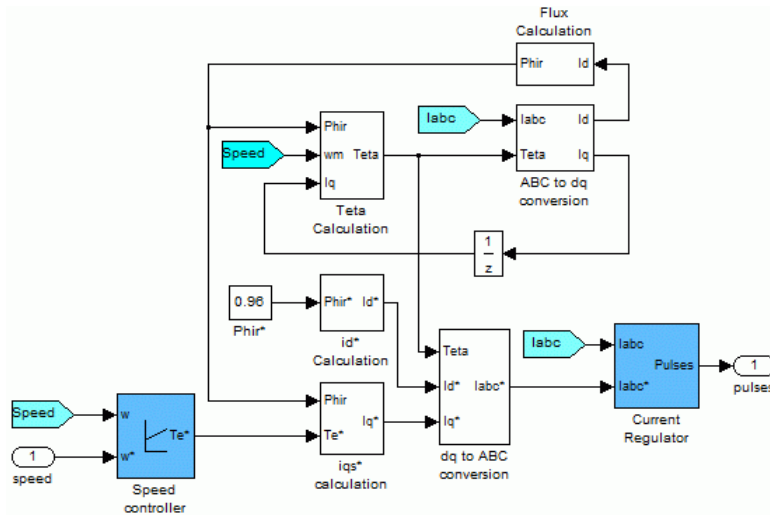

Vector Control Block

The IGBT inverter is modeled by a **Universal Bridge** block in which the **Power Electronic device** and **Port configuration** options are selected as IGBT/Diode and ABC as output terminals respectively. The DC link input voltage is represented by a 780 V DC voltage source.

The current regulator consists of three hysteresis controllers and is built with Simulink blocks. The motor currents are provided by the measurement output of the **Asynchronous Machine** block.

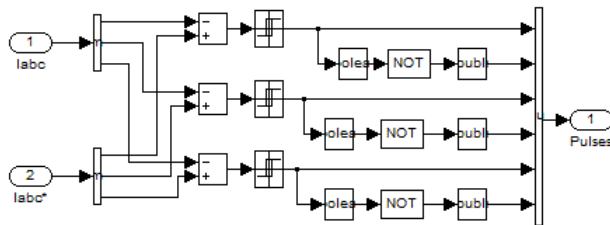

The conversions between abc and dq reference frames are executed by the abc_to_dq0 Transformation and dq0_to_abc Transformation blocks

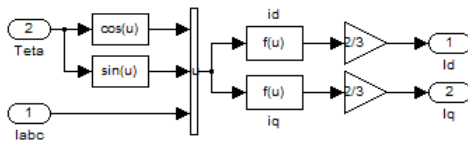

abc_dq

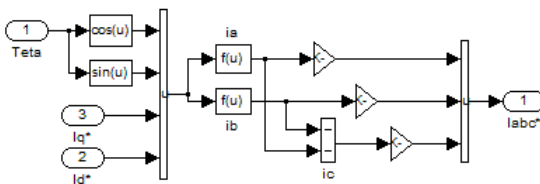

dq_abc

The rotor flux is calculated by the Flux_Calculation block.

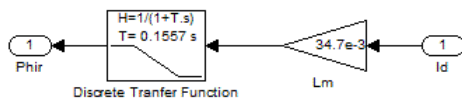

The rotor flux position (Θ_e) is calculated by the Theta Calculation in Vector Control Block. The motor speed is provided by the measurement output of the Asynchronous Machine block.

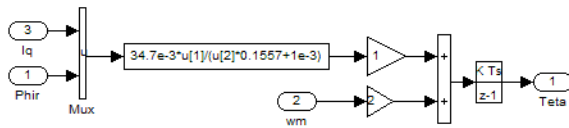

The stator quadrature-axis current reference (i_{qs}^*) is calculated by the i_{qs}^* _Calculation block.

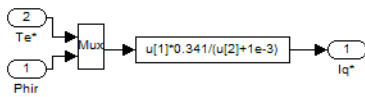

The stator direct-axis current reference (i_{ds}^*) is calculated by the i_{ds}^* _Calculation block.

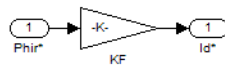

The speed controller is of proportional-integral type and is implemented using Simulink blocks.

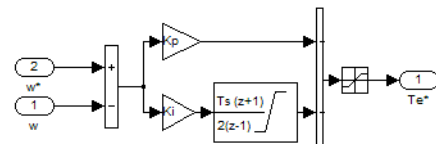

Simulating the Induction Motor Drive

In order to increase simulation speed, this model is discretized using a sample time of $2 \mu\text{s}$. The variable $T_s = 2e-6$ automatically loads into your workspace when you open this model. This sample time T_s is used both for the power circuit (T_s specified in the Powergui) and the control system.

Run the simulation by selecting **Simulation > Run**.

The motor voltage and current waveforms as well as the motor speed and torque are displayed on four axes of the scope connected to the variables V_{ab} , I_{abc} , ω_m , and T_e .

Starting the Drive

You can start the drive by specifying $[1, 0, 0, 0, 0, 0, 0, 0]$ as the initial conditions for the Asynchronous Machine block (initial slip = 1 and no currents flowing in the three phases). The speed reference is 120 rad/s.

The motor speed, electromechanical torque, and currents observed during the starting of the induction motor drive are shown in Starting the Induction Motor Drive.

Note that you can save the final system state vector x_{Final} by selecting **Simulation > Configuration parameters > Data Import/Export**, and then selecting the **Final states** check box under **Save to workspace**. It can be used as the initial state in a subsequent simulation so that the simulation can start under steady-state conditions.

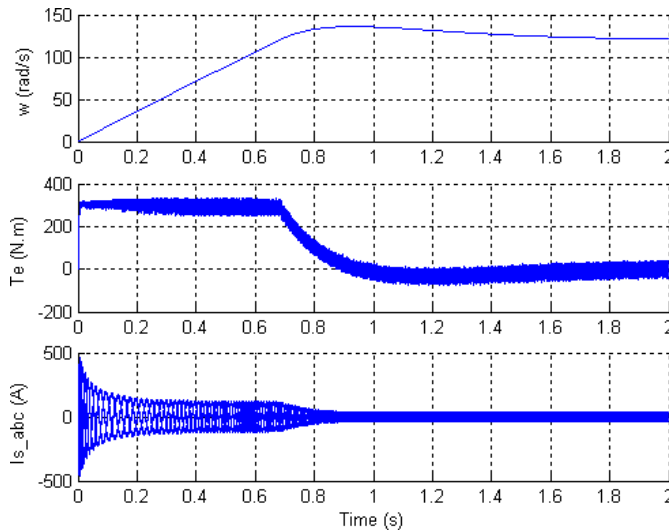

Starting the Induction Motor Drive

Steady-State Voltage and Current Waveforms

When the steady state is attained, you can stop the simulation and zoom on the scope signals.

This figure shows the motor voltage, current, and torque waveforms obtained when the motor is running at no load (torque = 0 N.m) at a speed of 120 rad/s.

The 20 A band imposed by the hysteresis current regulator is clearly seen on the three motor currents.

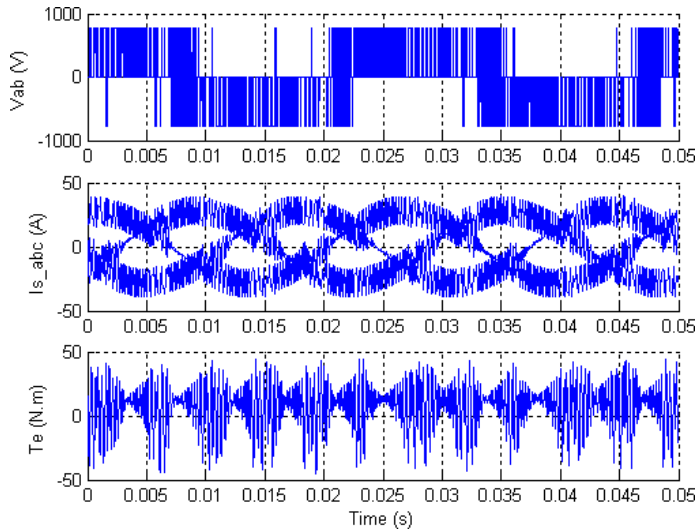

Steady-State Motor Current, Voltage, and Torque Waveforms

Speed Regulation Dynamic Performance

You can study the drive dynamic performance (speed regulation performance versus reference and load torque changes) by applying two changing operating conditions to the drive: a step change in speed reference and a step change in load torque.

Use the Reference Speed selection switch and the Torque selection switch to set speed reference steps from 120 rad/s to 160 rad/s at $t = 0.2$ s and the load torque steps from 0 N.m to 200 N.m at $t = 1.8$ s. The final state vector obtained with the previous simulation can be used as the initial condition so that the simulation starts from steady state. Load the power_acdrive_init.mat file, which creates the `xInitial` variable. Select **Simulation > Configuration parameters > Data Import/Export**, then select the **Initial state** check box under **Load from workspace** and click **OK**, and then restart the simulation.

The response of the induction motor drive to successive changes in speed reference and load torque is shown here.

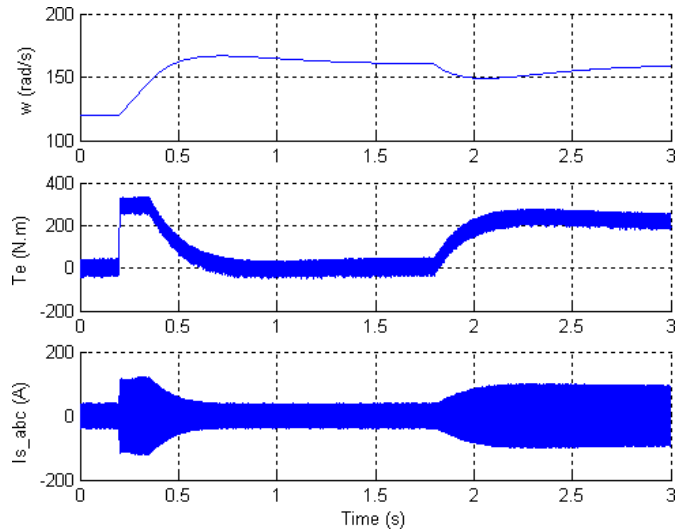

Dynamic Performance of the Induction Motor Drive

References

- [1] Leonhard, W., *Control of Electrical Drives*, Springer-Verlag, Berlin, 1996.
- [2] Murphy, J. M. D., and Turnbull, F. G., *Power Electronic Control of AC Motors*, Pergamon Press, Oxford, 1985.
- [3] Bose, B. K., *Power Electronics and AC Drives*, Prentice-Hall, Englewood Cliffs, N.J., 1986.

Retune the Drive Parameters

This section contains necessary information in order to modify the parameters of an electric drive. The method is based on an example which uses the AC3 drive model. In this example, the nominal power of the motor is changed from 200 hp to 5 hp. The complete procedure is described in order to:

- “Modify the Motor Parameters” on page 4-100
- “Retune the Parameters of the Flux Regulator” on page 4-101
- “Retune the Parameters of the Speed Regulator” on page 4-107
- “Retune the Parameters of the DC Bus Voltage” on page 4-111
- “Simulate and Analyze the Results” on page 4-113

Modify the Motor Parameters

- 1 Open the `ac3_example` example (type `ac3_example` in the MATLAB Command Window). The parameters are set for a 200 hp motor.
- 2 Simulate the model in accelerator mode and observe the results.
- 3 Double-click the **Field-Oriented Control Induction Motor Drive** block and select the **Asynchronous Machine** tab and copy into the drive's mask the 5 hp motor's parameters that are shown in the next figure.

Field-Oriented Control Induction Motor Drive

The AC motor parameters are specified in the AC Machine tab. The braking chopper, the diode rectifier and the inverter switches parameters are specified in the Converter and DC bus tab. F.O.C. and speed controller parameters are specified in the Controller Tab.

Asynchronous Machine Converters and DC bus Controller

Electrical parameters

Reference frame: Rotor

Discretization method: Forward Euler

Nominal values

Power (VA):	Voltage (Vrms):	Frequency (Hz):
3730	460	60

Equivalent circuit values

	Resistance (ohm):	Leakage inductance (H):	Mutual inductance (H):
Stator:	1.115	0.005974	0.2037
Rotor:	1.083	0.005974	

Initial currents

	Phase A:	Phase B:	Phase C:
Magnitude (A):	0	0	0
Phase (deg):	0	0	0

Mechanical parameters

Rotor values

Inertia (kg*m ²):
0.02
Friction (N-m-s):
0.005752
Pole pairs:
2

Initial values

Slip:
1
Angle (deg):
0

Enter the New Motor Parameters

Retune the Parameters of the Flux Regulator

In this section we start with the tuning of the flux regulator's parameters. The parameters are empirically tuned until a satisfactory response is obtained. When you retune the regulator's parameters, it is of primary importance to visualize the reference signals and the variables of these two regulators.

- 1 In order to measure the signals associated to the flux regulator, add into the demux subsystem the blocks shown in the next figure:

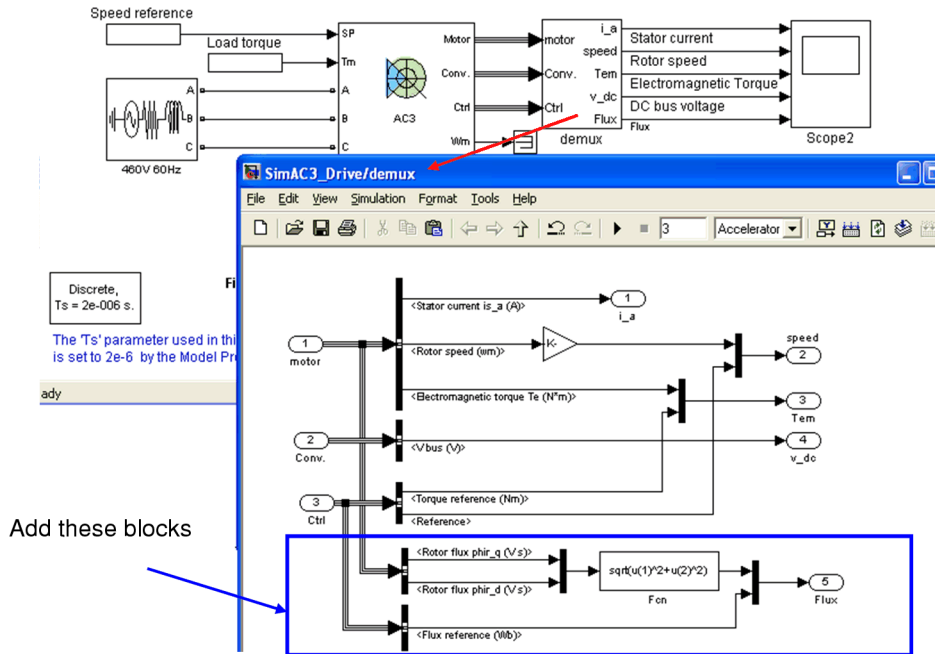

Add Blocks to Measure Flux Regulator Signals

- 2 Select the **Controller** tab in the mask of Field-oriented Control Induction Motor Drive block and set the **Regulation type** to **Torque regulation** to access the controller parameters.

The torque regulation mode is required in order to bypass the speed regulator parameters and act directly on the FOC controller.

Remember that the current controlled by the FOC controller depends of the machine flux. The flux controller ensures that the required flux is correctly applied to the machine.

- 3 Set the **Lowpass filter cutoff frequency** to 10 kHz in order not to limit the flux frequency. The highest flux frequency depends of the switching frequency.

Set also the **Flux output limits** to 150% of the **Nominal flux**, the **Proportional gain** to 1, the **Integral gain** to 0, the **hysteresis band** to 1 and the **Machine flux** to 0.705. This last value is computed as follows:

$$\frac{V_{LL}(rms)}{\sqrt{3} \cdot 2 \cdot \pi \cdot f} = \frac{460}{\sqrt{3} \cdot 2 \cdot \pi \cdot 60}$$

Reset the Flux Regulator Parameters

- 4 To apply the nominal torque to the motor, modify the torque set point and the load torque blocks as shown in the next figure.

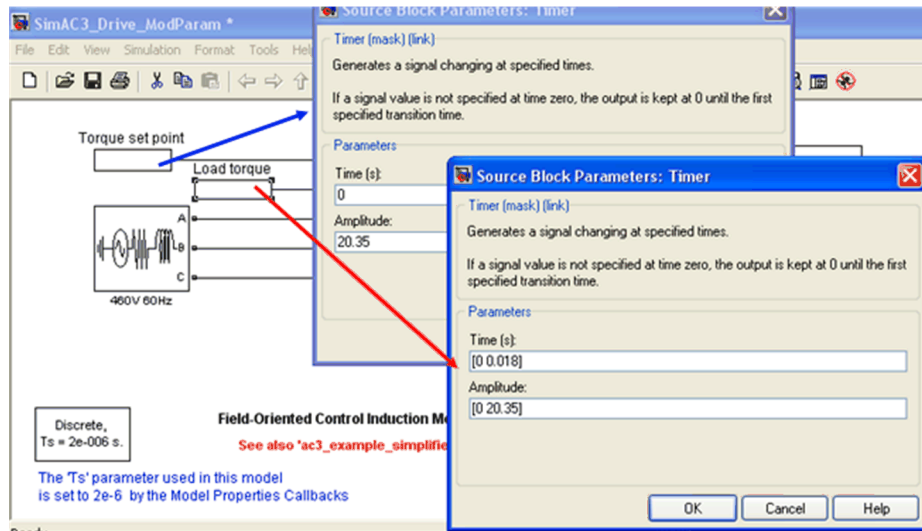

Set Points in Torque Regulation Mode

- 5 Set the **sampling decimation** of the scope block to 1, the **Variable name** to **simout1** and check the **Save data to workspace** parameter with a Structure with time format.

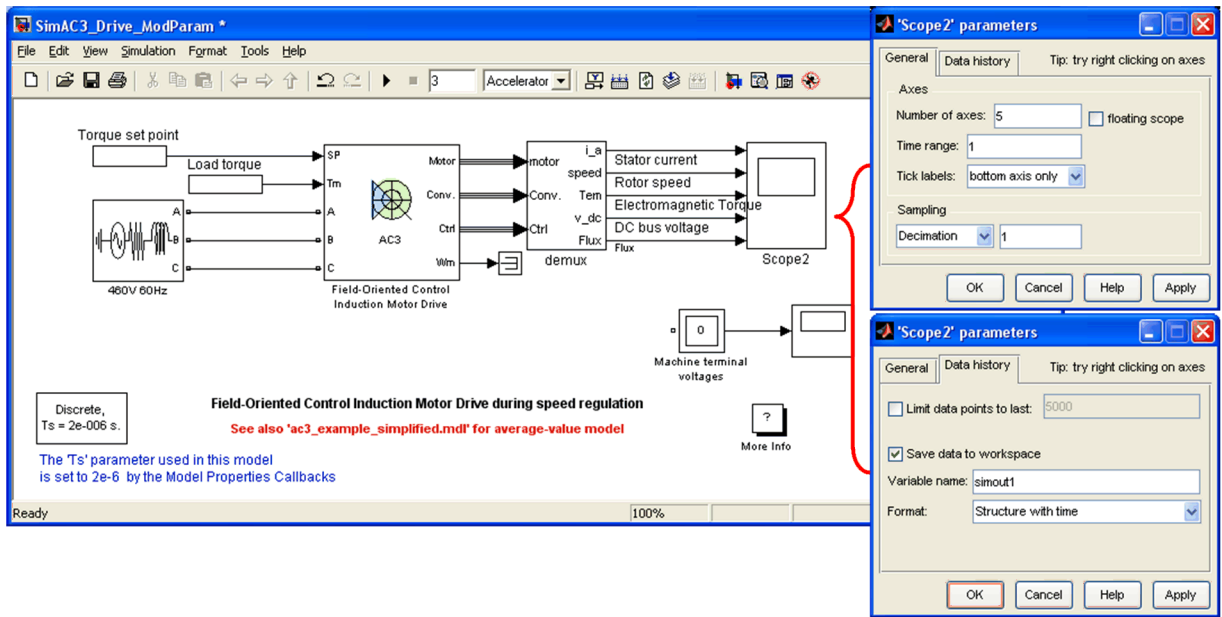

Set the Scope Parameters

- 6 Simulate the system for 0.5s then open the **powergui** and click on **FFT analysis**.

Select the **Stator current** signal in the **Input** list and specify the **Start time** = 0.23, the **Number of cycle** = 1, a **Fundamental frequency** = 7.5, and a **Max Frequency (Hz)** = 20 000 Hz.

Click on the **Display** button to get the FFT graph shown on the next figure.

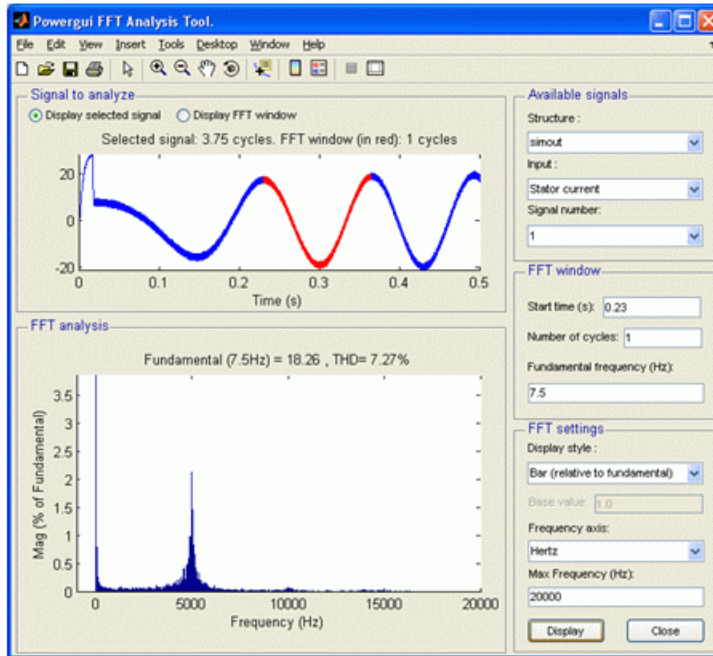

- 7 Observe the switching frequency of about 5 kHz. To attenuate this frequency, set the Flux controller **Lowpass filter cutoff frequency** parameter to 500 Hz.
- 8 Open the Scope block and observe the flux signal. Note that the steady state error is high and the time response is not really good:

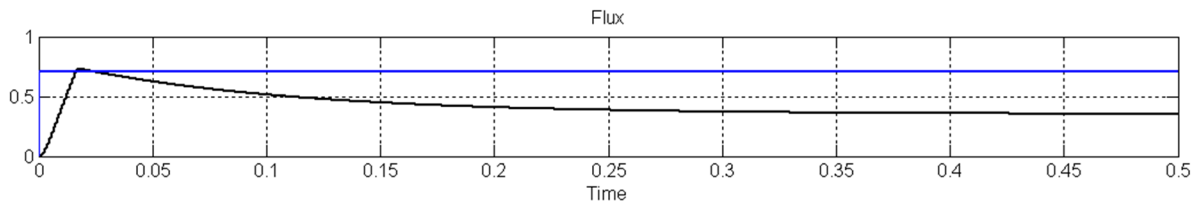

- 9 Gradually increase the **Proportional gain** parameter of the controller and simulate until you obtain a satisfactory response. Increasing the gain above a certain value can cause a saturation of the Flux controller. The curve at the next figure is obtained with a proportional gain of 100.

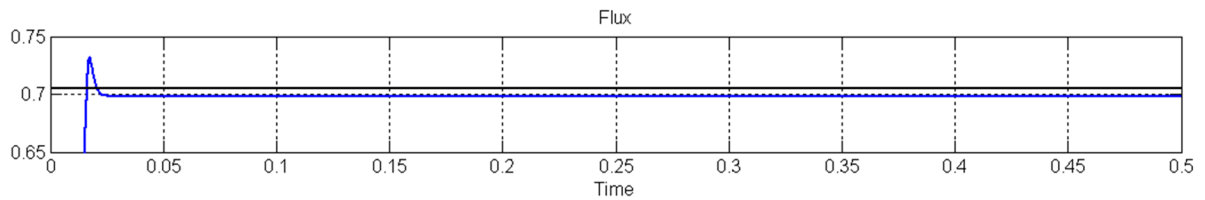

- 10 Gradually increase the **Integral gain** and simulate until you obtain a satisfactory steady state result with minimal error. The next plot is obtained with a integral gain of 90.

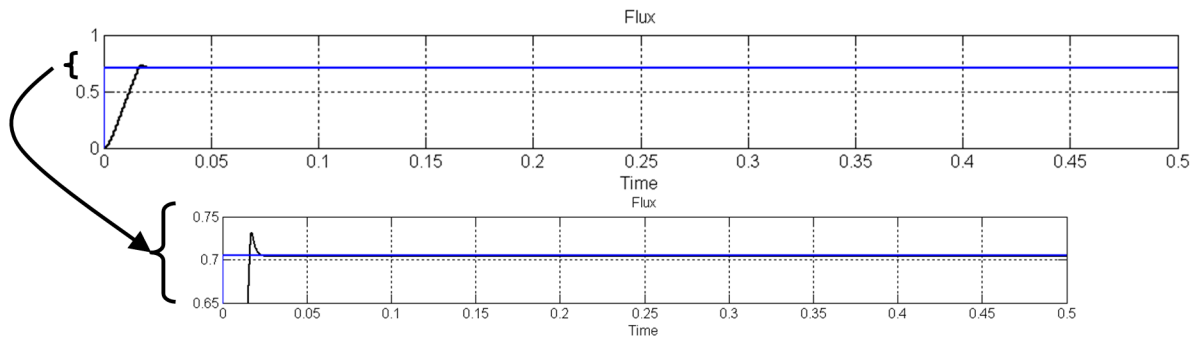

Flux Regulator: Ki Tuning

Retune the Parameters of the Speed Regulator

In this section we are tuning the speed controller parameters. The regulator's parameters are empirically tuned until a satisfactory response is obtained.

- 1 Select the **Controller** tab in the mask of Field-oriented Control Induction Motor Drive block and set the **Regulation type** to **Speed regulation** to edit the controller parameters.

Set the **Torque output limits** to 150% of the nominal torque, the **Proportional gain** to 1, the **Integral gain** to 0, the **Speed cutoff frequency** to 500.

The highest speed frequency depends also on the switching frequency so take the same value as for the flux regulator **lowpass filter cutoff frequency**.

The speed ramp acceleration must be calculated not to exceed the torque output limit. The required torque to accelerate the motor at 1750 rpm/s is given by:

$$T_{accel} = J \cdot \frac{Accel((rpm)/s)}{30} \cdot \pi$$

$$T_{accel} = 0.02 \cdot \frac{1750}{30} \cdot \pi = 3.67 \text{ Nm}$$

- 2 In order to apply the nominal torque to the motor, modify the speed set point and the load torque, as shown in the following figure.

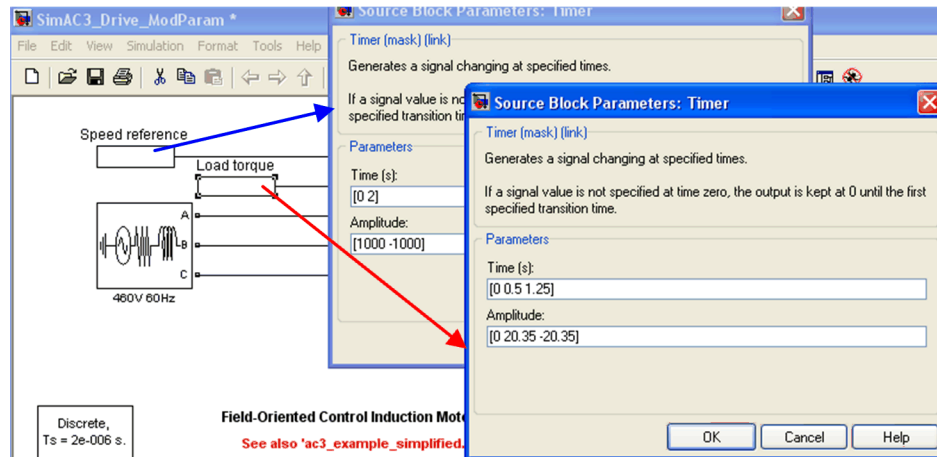

Set Points in Speed Regulation Mode

- 3 Set the scope decimation to 25 in order not to overload the memory. Start the simulation.

Observe the speed signal on the Scope block. The steady state error is high and the response time is not really good:

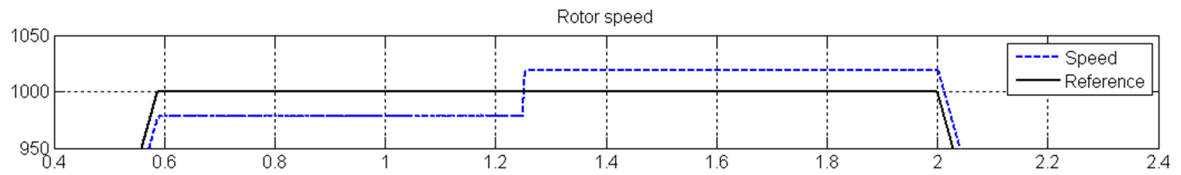

Poor Speed Response

- 4 Gradually increase the **Proportional gain** parameter of the controller and simulate until you obtain a satisfactory response time without overshoot. Note that if the gain is too high, the system will be oscillatory. The next plot is obtained with a proportional gain of 3.

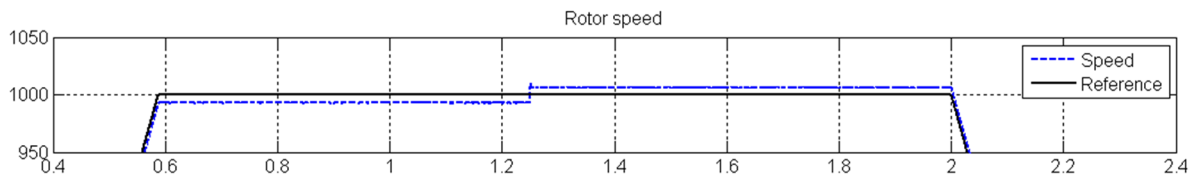

Speed Regulator: Kp Tuning

- 5 Gradually increase the **Integral gain** and simulate until you obtain a satisfactory steady state value with a minimal steady state error. The curve at the next figure is obtained with a integral gain of 100.

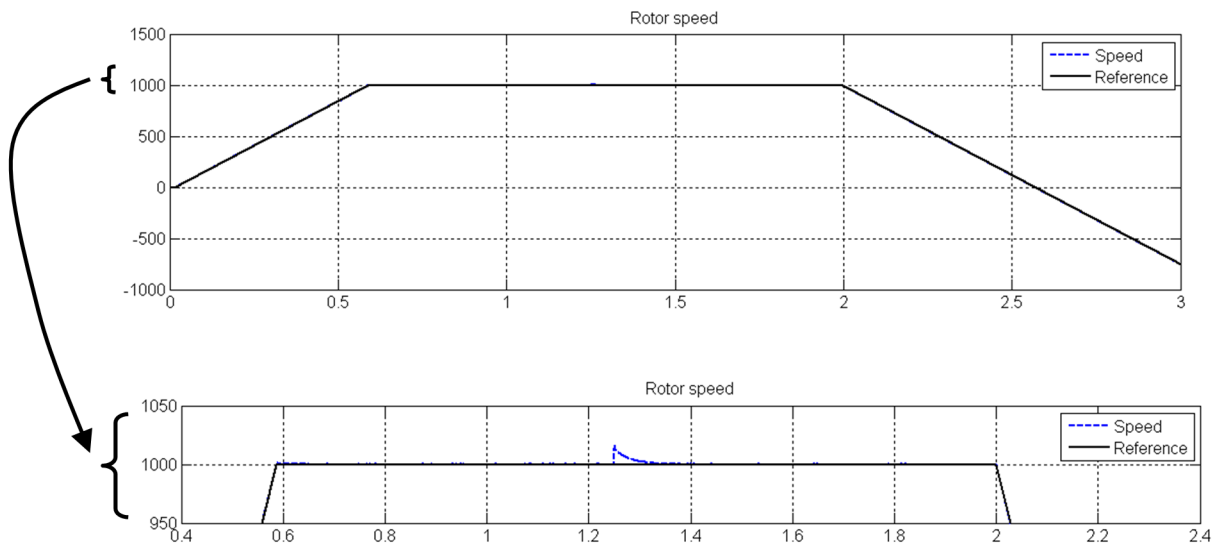

Speed Regulator: Ki Tuning

6 The final drive regulators parameters are shown in the next figure.

Regulator Parameters

Retune the Parameters of the DC Bus Voltage

- 1 Select the **Converter and DC bus** tab in the mask of Field-oriented Control Induction Motor Drive block to tune the DC bus capacitor and the braking chopper parameters.
- 2 Set the **DC Bus Capacitance** parameter to $167e-6$.

The DC bus capacitance is calculated in order to reduce the voltage ripple. It is calculated as follow:

$$C = \frac{P_{motor}}{12 \cdot f \cdot \Delta_V \cdot V_{DC}}$$

where:

- P_{motor} is the nominal power of the motor drive (W)
- f is the frequency of the AC source (Hz)
- Δ_V is the desired voltage ripple (V)
- V_{DC} is the average DC Bus voltage (V)

This equation gives an approximate value of the capacitor required for a given voltage ripple level. Here the desired voltage ripple is 50V.

The motor drive of 5 hp (3728W) is fed by a 60Hz three-phase source. The average DC bus voltage is given by: $V_{DC} = 1.35 \cdot V_{LL}$, where V_{LL} represents the line to line rms voltage of the source. The source line to line voltage is 460 Vrms so the DC voltage is: $V_{DC} = 621$ V.

The required capacitor is then equal to:

$$C = \frac{3728}{12 \cdot 60 \cdot 50 \cdot 621} = 167 \mu\text{F}$$

- 3** Set the **Braking chopper Shutdown voltage** to 660V and the **Braking chopper Activation voltage** to 700V.

In motor mode, the peak voltage of the DC bus is equal to:

$$V_{peak} = V_{LL} \cdot \sqrt{2} = 460 \cdot \sqrt{2} = 650 \text{ V}$$

The shutdown voltage (V_{shut}) of the braking chopper should be a little bit higher than this value. The shutdown voltage is set to 660V and the activation voltage (V_{act}) is set to 700V in order to limit the voltage increase during regenerative braking.

- 4** Set the Braking chopper **Resistance** to 131 ohms.

The braking chopper resistance is calculated with the following relation:

$$R = \frac{V_{act}^2}{P_{motor}} = \frac{700^2}{3728} = 131 \Omega$$

- 5 The final DC bus parameters are shown in the next figure.

Field-Oriented Control Induction Motor Drive

Field-Oriented Control Induction Motor Drive

The AC motor parameters are specified in the AC Machine tab. The braking chopper, the diode rectifier and the inverter switches parameters are specified in the Converter and DC bus tab. F.O.C. and speed controller parameters are specified in the Controller Tab.

Asynchronous Machine Converters and DC bus Controller

Rectifier

Snubbers

Resistance (ohm): 10e3

Capacitance (F): 20e-9

Diodes

On-state resistance (ohm): 1e-3

Forward voltage (V): 1.3

DC Bus

Capacitance (F): 167e-6

Braking chopper

Resistance (ohm): 131

Chopper frequency (Hz): 4000

Activation voltage (V): 700

Shutdown voltage (V): 660

Inverter

Switches

Device type: IGBT / Diodes

On-state resistance (ohm): 1e-3

Forward voltages (V)

Main device: 0.8

Diode: 0.8

Turn-off characteristics

Fall time (s): 1e-6

Tail time (s): 2e-6

Snubbers

Resistance (ohm): 5e3

Capacitance (F): inf

Output bus mode: Multiple output buses Mechanical input: Torque Tm

Model detail level: Detailed

Parameters file options

Load Save

OK Cancel Help Apply

DC Bus Parameters

Simulate and Analyze the Results

The overall simulation results are shown at the next figure:

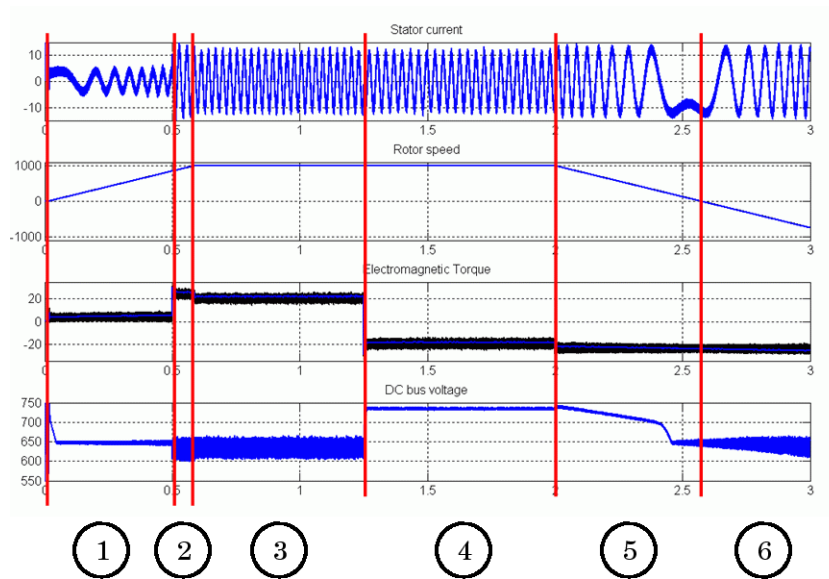

Simulation Results

The results are composed of six main sections

- 1 No-load acceleration
- 2 Nominal load torque is applied
- 3 Steady state speed
- 4 Nominal generation torque is applied: Observe the DC bus voltage overshoot
- 5 Deceleration
- 6 Negative speed Acceleration

Modify a Drive Block

If you have to change electrical connections or control modules, you can do so by modifying a drive block. The following example uses `ac6_example` to replace the three-phase electric source by a battery. To modify a drive block, use the steps described in the following sections:

- “Break the Link of the Drive Block” on page 4-115
- “Modify the Drive Block” on page 4-115
- “Use the Customized Drive Block” on page 4-117
- “Simulate the System and Observe the Results” on page 4-119

Break the Link of the Drive Block

- 1 Open the `ac6_example` by typing `ac6_example` in the MATLAB Command window. The drive is fed by a three-phase voltage source.
- 2 Simulate the model (in accelerator mode) and observe the results.
- 3 Break the link between the drive block and the Electric Drives library. Right-click the block that you copied, and from the context menu select **Library Link > Disable Link**. Right-click the block again, and select **Library Link > Break Link**.

Modify the Drive Block

- 1 Right-click the drive block and select **Look Under Mask**.
- 2 Delete the three-phase electrical connections, the diode rectifier, and the braking chopper.

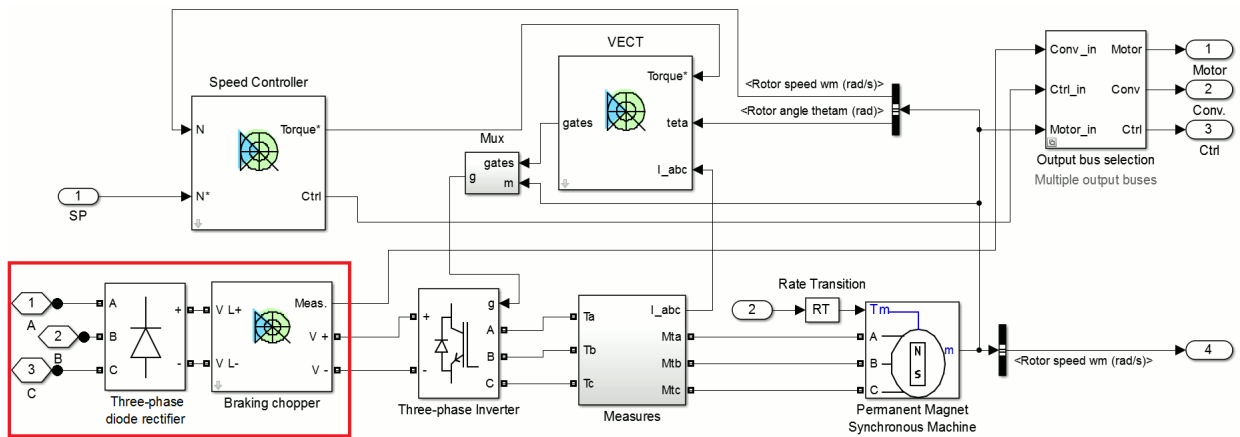

Remove the AC Blocks

- 3 Add two Connection Ports blocks from the Fundamental Blocks/Elements library, and then connect them to the positive and negative terminals of the Three-Phase Inverter block. Add a Simulink Ground block and connect it to the output port Conv.

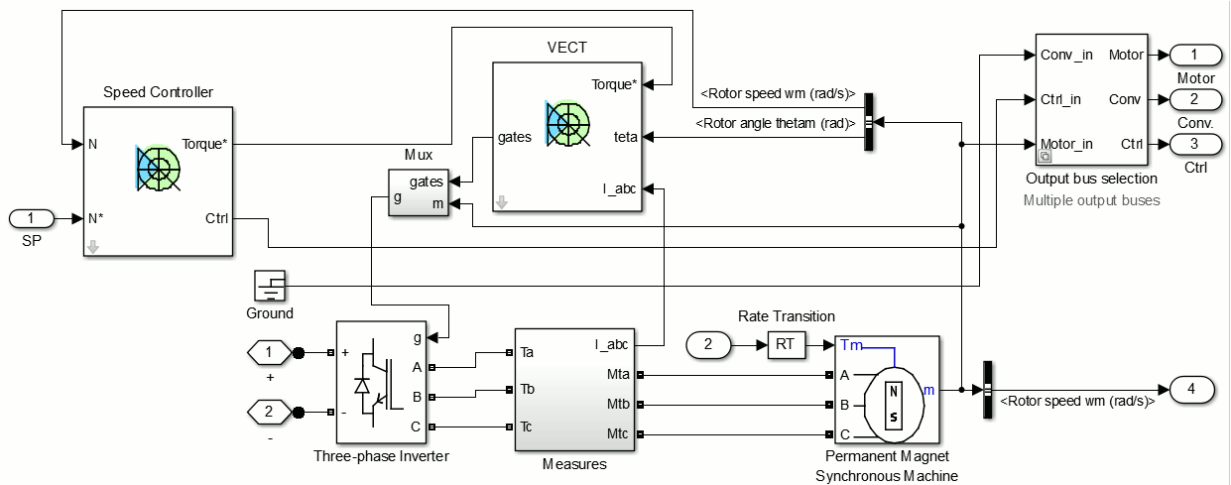

Use the Customized Drive Block

- 1 Save the model as ac6_example2.
- 2 On the diagram, delete the three-phase source. Replace it by a 300Vdc/1Ah/NiMH Battery block and a 100 μ F capacitor block connected in parallel.

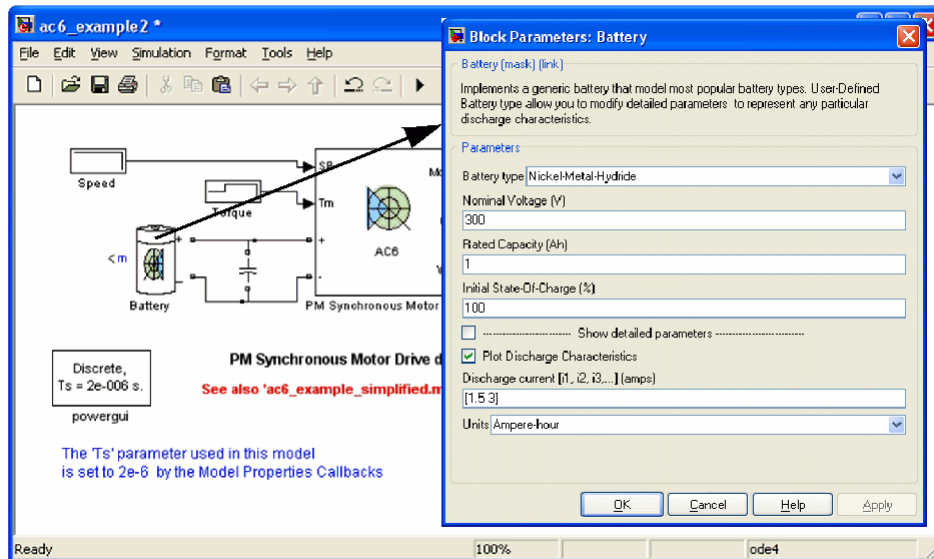

- 3 Connect the Conv output of the block to a Terminator block. Remove the DC bus voltage blocks that are in the Demux block.

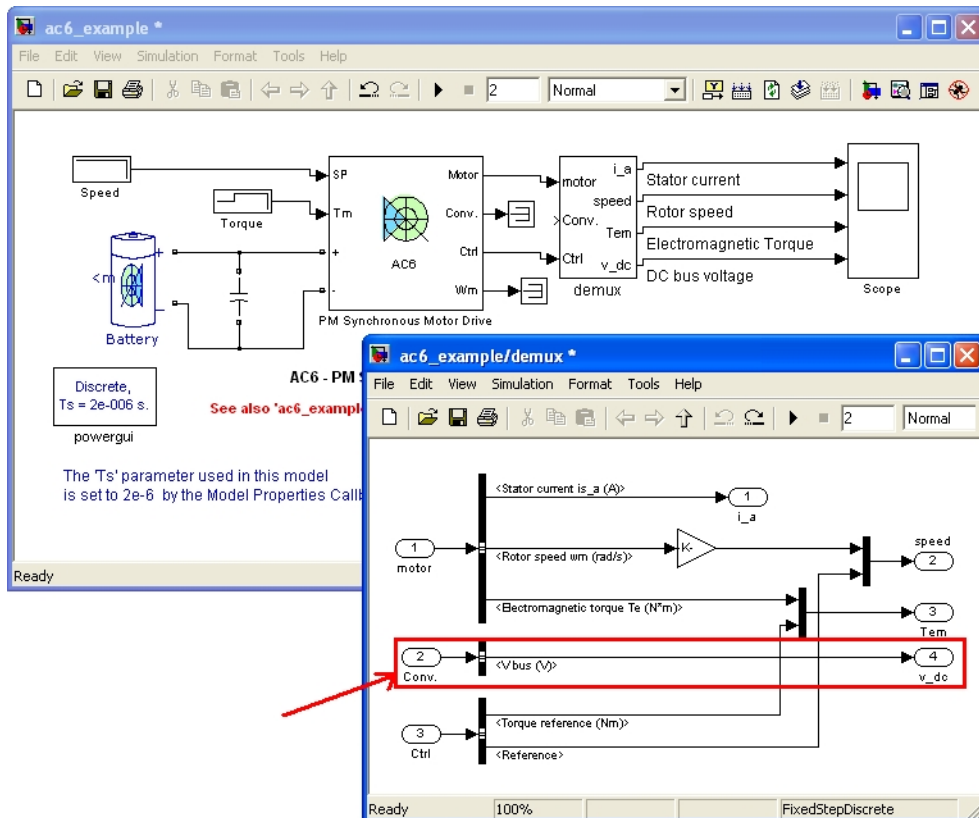

Remove DC Bus Measurement in the Demux Block

- 4 Add a **Bus Selector** block and then select the **Voltage (V)** bus signal coming from the **m** output of the **Battery** block.

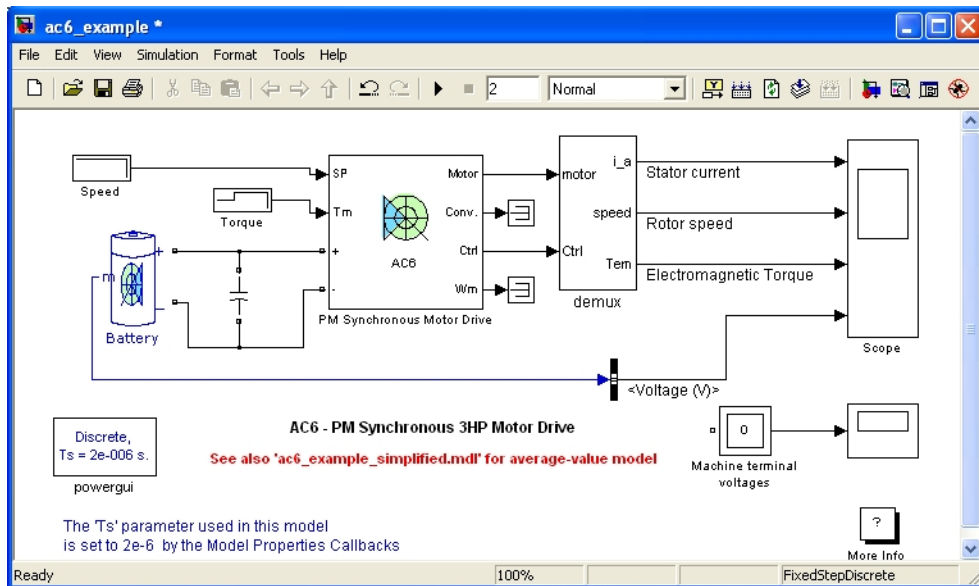

Observe the Battery Voltage

Simulate the System and Observe the Results

The overall simulation results are shown at the next figure.

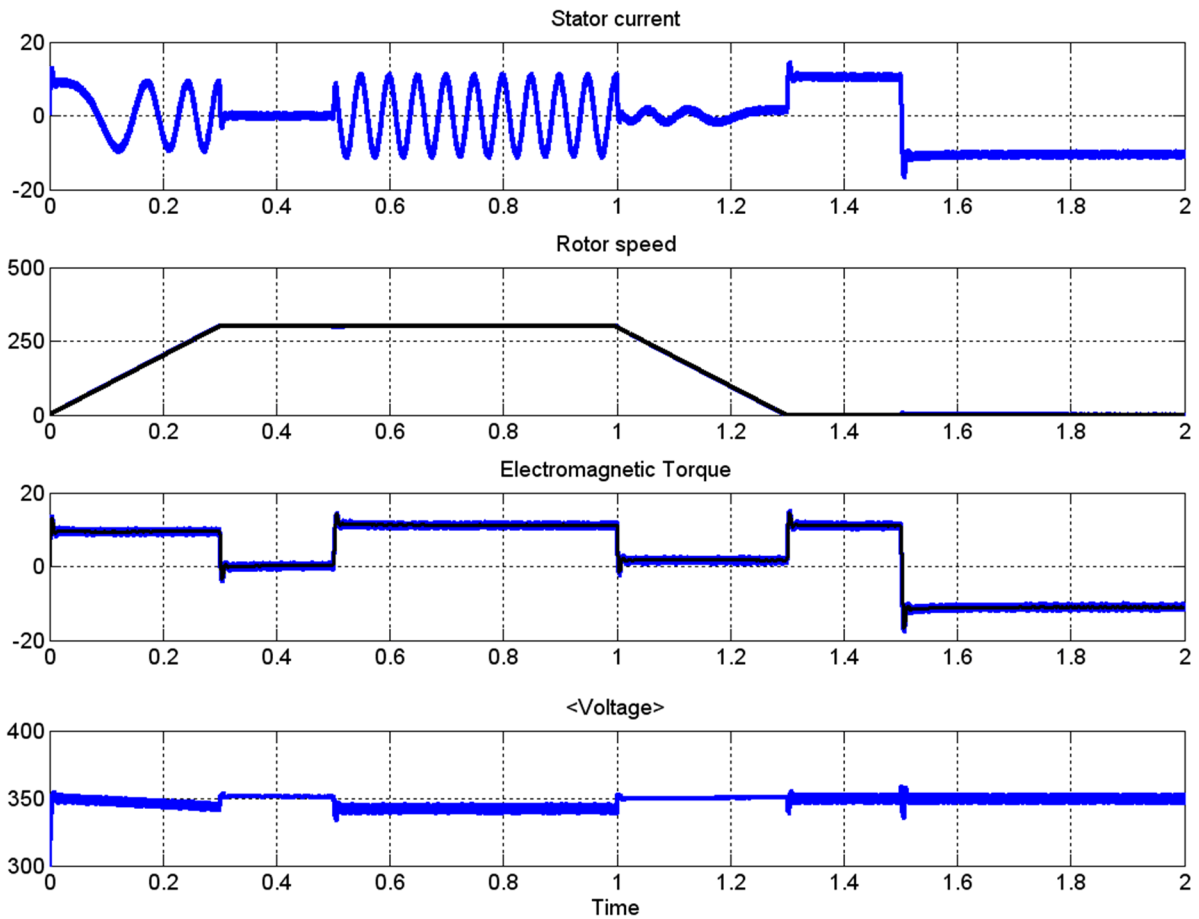

Simulation Results

The GUI of the Modified Drive Block

Because you have broken the link from the drive block to the Electric Drives library and customized the block contents, the synchronization of the GUI parameters with the block parameters underneath the block might differ from usual block behavior.

The parameter synchronization process relies on three assumptions:

- The GUI expects the presence of specific blocks with predetermined mask type names
- The GUI expects the presence of specific blocks with predetermined mask variable names
- The GUI is nonmodifiable

If you rename the **Mask type** parameter of expected blocks, or remove blocks with expected mask types, the parameters in the GUI that are associated with these blocks will display **undefined**.

If you rename or remove an expected mask variable name, the parameter in the GUI that is associated with this variable will display **undefined**.

A warning dialog appears every time the synchronization process fails to find blocks with expected mask types or blocks with expected mask variable names. You can disable the display of these warnings by right-clicking on the drive block, selecting **Mask Parameters** from the context menu, and clearing the **Show mask synchronization warnings** check box.

As a general guideline, as long as you do not alter or remove any mask type or mask variable name from the blocks composing the drive block, the GUI will behave exactly as expected.

You can add blocks or subsystems inside the drive block, but the associated parameters will not be available in the drive block's GUI. You have to use the **Diagram > Mask > Look Under Mask** menu item to access these parameters.

Multi-Level Modeling for Rapid Prototyping

In this section...
“Introduction” on page 4-122
“The System Architecture” on page 4-123
“The Simplified Model” on page 4-123
“The Average-Value Model” on page 4-127
“The Detailed Model” on page 4-133
“Comparison of the Multi-Level Modeling Precision” on page 4-136
“Conclusion” on page 4-141

Introduction

Model-based design can considerably reduce the cost associated with system development. The development of models for complex systems such as electric vehicles includes the following phases:

- Definition of functional specifications
- System design
- Tests and validation
- Implementation

This case study focuses on the first two phases and shows how the simulation could help the system designer in decision making. The simulation is a very complex art. It can represent simple model with precision which can be arguable whereas complex models can be represented with accurate precision, very close to reality. The developer of models must always make a compromise between the complexity of the models and the required precision. Of course, it is always preferable to have an ultra-accurate model, but the parameters required by these models are usually difficult to determine, especially during the first phases of system development. Moreover, the simulation of these accurate models is very slow.

It is therefore necessary to use different detail level of simulation models. At first, the system designer will need a first level model in order to have an overview of all the power flow in the system. This will help in the design of different elements in the system to meet the power flow requirement. Then, a more accurate model is required in order to adjust different systems, to fine tune the parameters of the energy management system

and to design power electronics converters. Finally, a detailed model will allow the validation of the system behavior with a high degree of accuracy and to perform other adjustments if required.

The System Architecture

The system architecture under study is based on the Toyota Prius THSII:

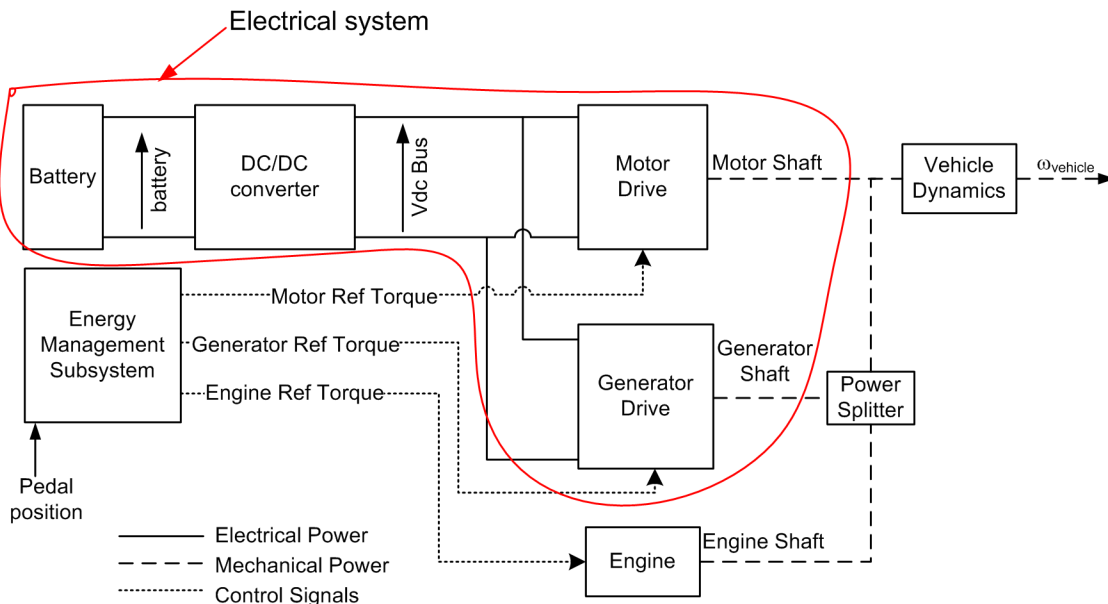

More precisely, the study focuses on the different detailed levels of the electrical system model.

The battery model used is the basic model from the SimPowerSystems library and requires few parameters. A NiMH battery of 201 V, 6.5 Ah (just as the one used in the Toyota Prius) is considered. For this model, it is not necessary to use different detailed level as it is very easy to use and offers a good precision.

The Simplified Model

The simplified electrical model is based on the power balance principle on different elements. Note that these simplified models have energy efficiency of 100%.

The DC/DC Converter

For the DC/DC converter, it is assumed that the DC bus voltage, which supplies the motor and the generator, is maintained constant by a regulator. For this model, a DC bus of 500 V is required. The voltage at the DC bus side is maintained constant using a fixed voltage source. From the power balance principle, the corresponding current is requested from the battery. A filter is necessary to break the algebraic loop. Below is the simplified DC/DC converter model:

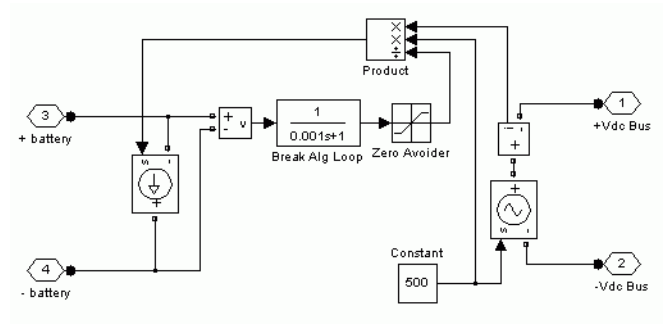

The Motor Drive

The electrical motor applies a mechanical torque on the system. The required torque is determined by the energy management system. It is assumed that the torque regulator is well designed so that the reference torque is directly applied on the motor shaft. By measuring the shaft speed and the DC bus voltage, it is possible using the power balance principle to determine the corresponding DC bus current. Below is the simplified model of the electrical motor:

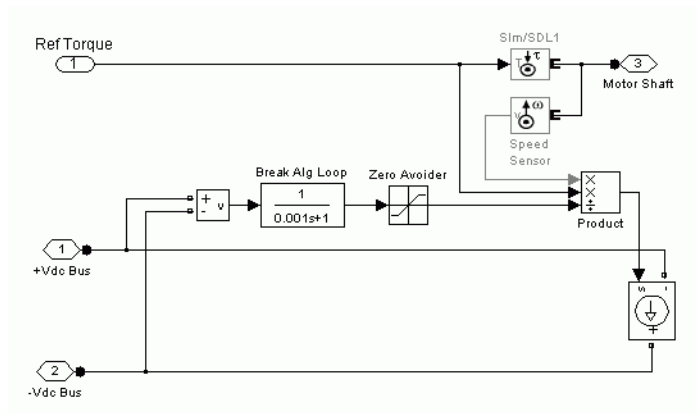

The Generator Drive

The generator is represented exactly as the electrical motor. A negative torque is requested by the energy management system in order to generate electrical power. As it is assumed that the generator control system is ideal, the reference torque is directly applied to the mechanical system. The corresponding current is deduced using the power balance principle.

Simulation Results

The simulation of the simplified electrical system is useful as it shows the performance of the energy management system, the mechanical system and different electrical components. In fact, the short simulation time (around 0.7 times the real time in normal mode) allows fast adjustments of the energy management system for better performances. For this phase of simulation, the accelerator position is set to 100% and the following results are obtained:

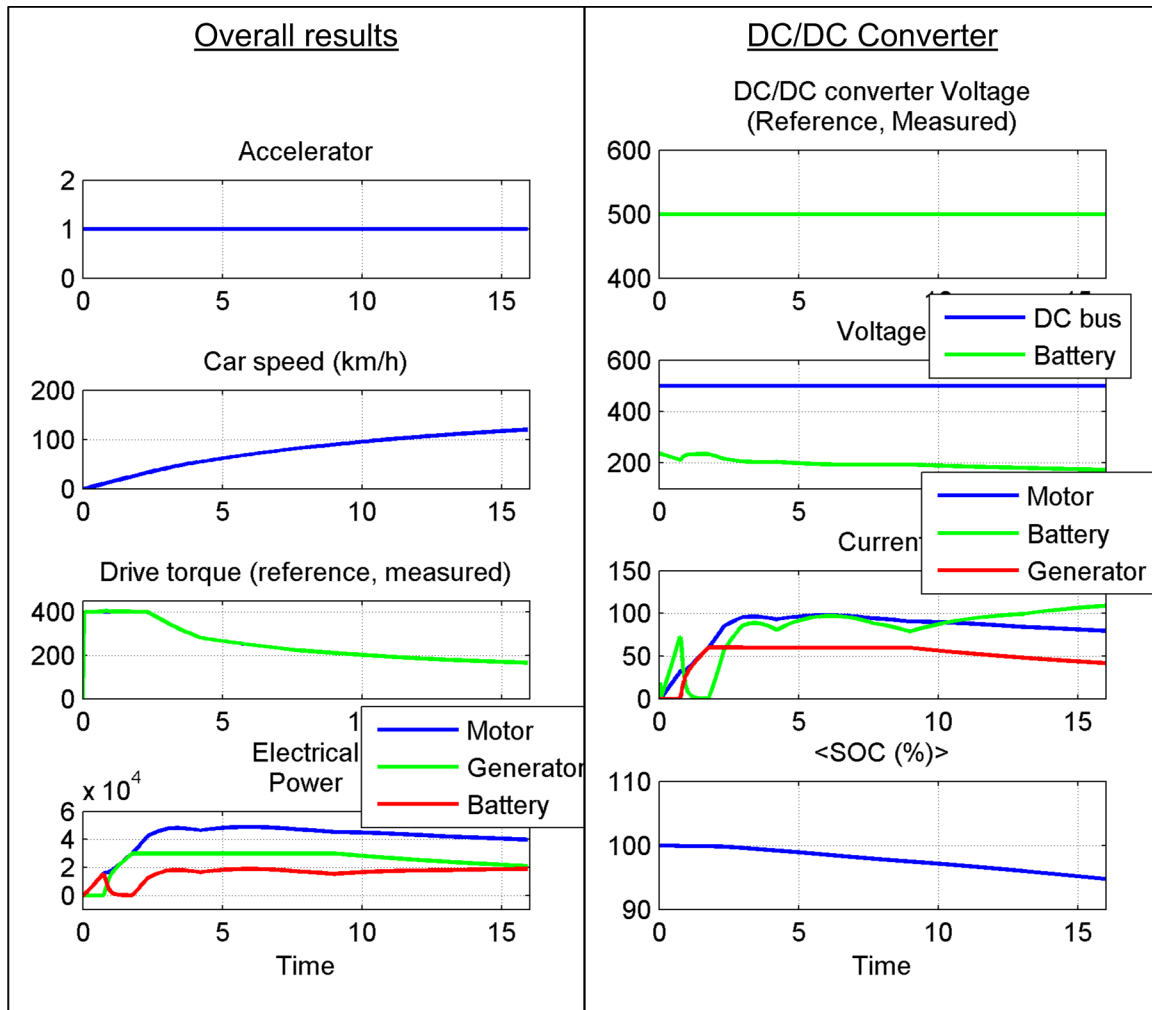

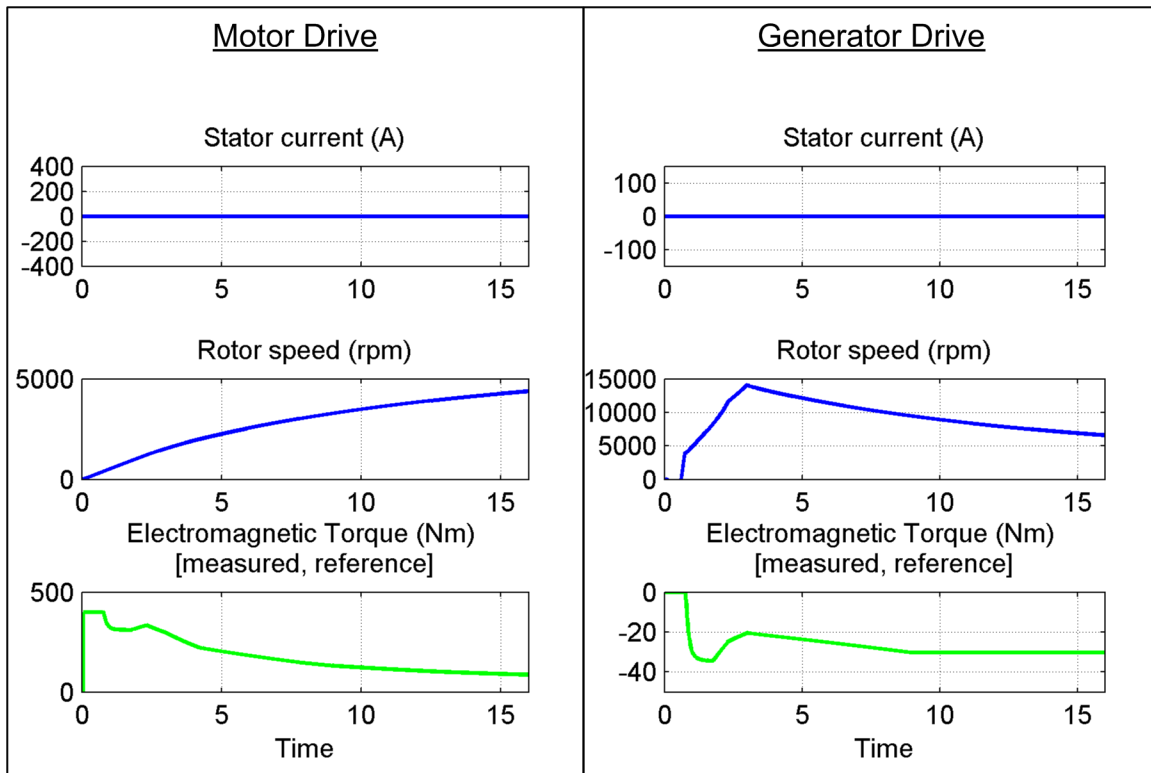

It should be noted that in this phase of modeling, it is not possible to determine the stator current for the motor and generator; that explains why these currents are nulls. The simplified model can now help in the dimensioning of each component of the electrical system. The next section focuses on the architecture of each component, including the electrical machines and different regulators.

The Average-Value Model

In this phase of simulation, the level of precision is improved. The different electrical machines and regulators architectures are chosen.

The DC/DC Converter

The average value DC/DC converter uses a voltage regulator based on a Proportional-Integrator (PI) controller to maintain the DC bus voltage equal to the voltage reference

(of 500 V). The simulation allows the selection of the inductor and capacitors and the adjustment of the PI controller parameters in order to obtain the results similar to the simplified model. Below is the DC/DC converter model:

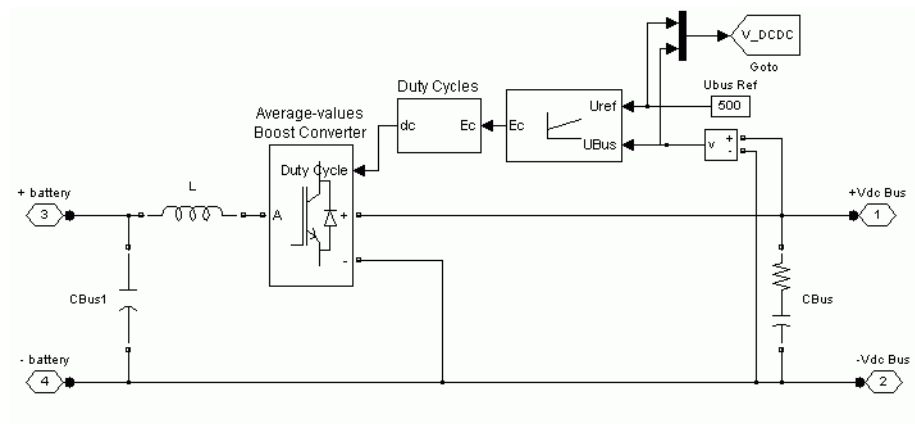

As an average value converter is used, only the duty cycle is required by the boost converter. The battery voltage is set by the boost converter based on the duty cycle and the DC bus voltage. On the high voltage side, the DC bus current is set based on the duty cycle and the battery current. For more information regarding this system, see “Average-Value Two-Quadrant Chopper”.

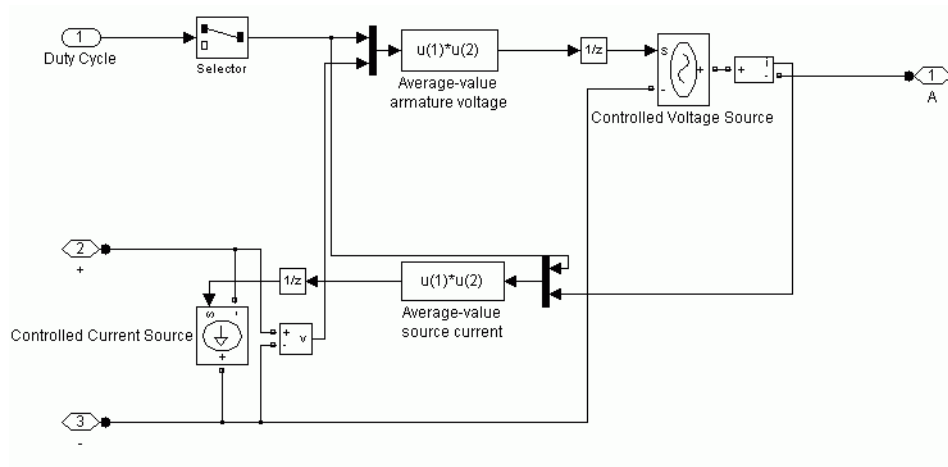

The Motor Drive

The motor is a permanent magnet synchronous machine (PMSM). From the simplified model results, the motor requirement is determined. It should be able to produce a maximum torque of 400 Nm and a maximum power of 50 kW up to 6000 rpm (this speed is obtained by simulating the simplified model for 60 seconds, in order for the vehicle to reach 160 Km/h).

The motor control is done using vector control. As the machine uses an interior permanent magnet rotor, it is possible to use the reluctance torque to increase the total output torque and operate at very high speed. For more information on this configuration, see the `ac6_IPMSM` example. The electric drive consists of the motor, the inverter and the vector controller.

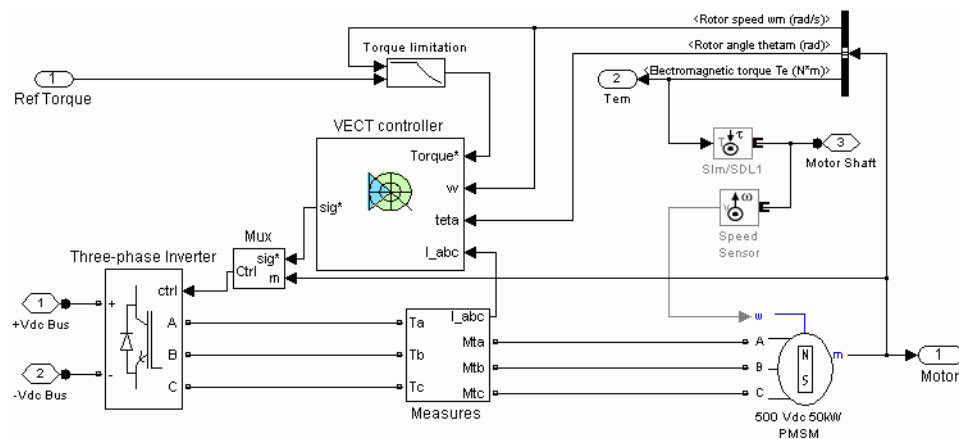

Similar to the DC/DC converter model, the inverter is represented by an average value model and the effect of power semiconductors switching is not taken into consideration. The reference currents (from the vector controller) are directly applied on the motor via controlled current sources. Moreover, this inverter allows the modeling of the saturation current when the DC bus voltage is not high enough to power the motor (at a given speed and torque). Below is the average value model:

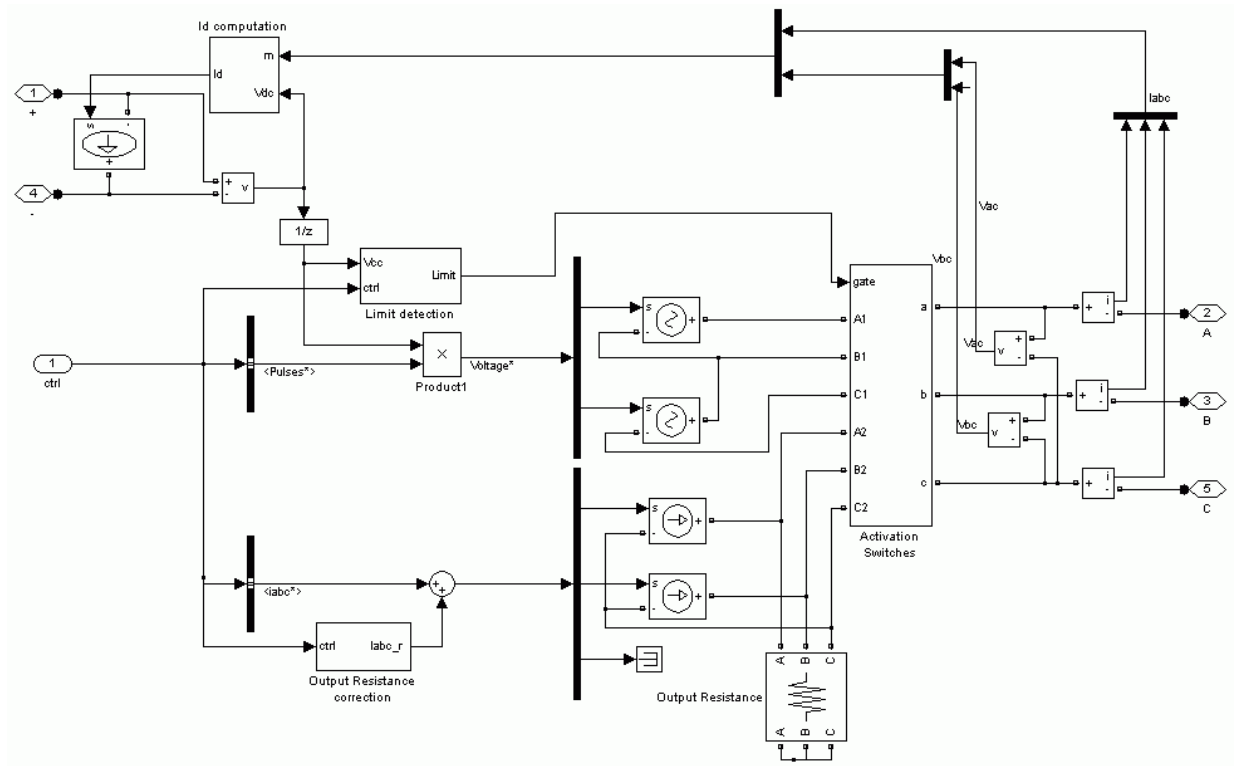

In normal operation, the current sources are used to supply the machine. In the saturation, mode, voltage sources are used instead. For more details on this system, see the PM Synchronous Motor Drive.

The Generator Drive

The generator is also a permanent magnet synchronous machine. From the simplified model results, it should be able to provide a maximum power of 30 kW and a maximum speed of 15 000 rpm. A vector controller is used to assure a proper operation of the generator. As a non-salient pole machine is used, the classical control method ($i_d = 0$) is used throughout the operating region. Below is the model of the complete system:

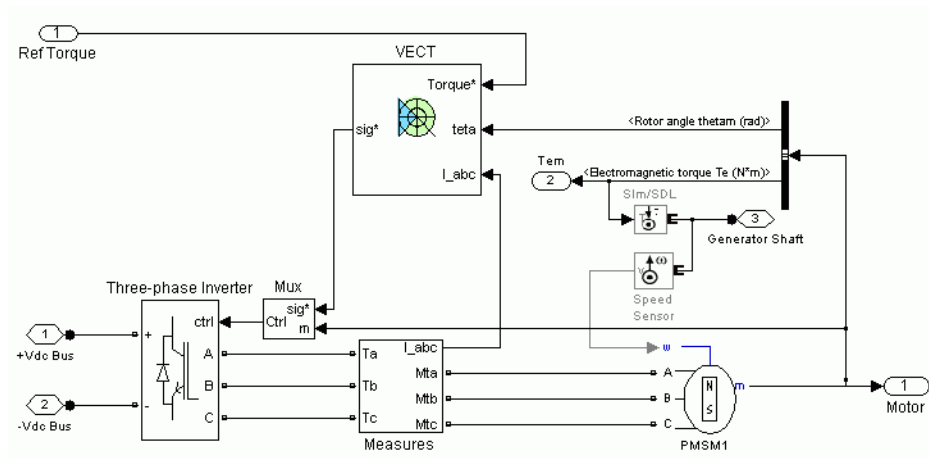

The average value model is identical for both the motor and generator.

Simulation Results

The simulation of the average value model allowed the dimensioning of electrical components (inductor, capacitor, motor and generator) and the adjustment of different controllers systems. At this stage, it is now possible to clearly visualize the electrical signals. This helps in fine tuning the regulators and the energy management system. The longer simulation time (16 times the real time in normal mode and 3.5 times the real time in accelerator mode) allows to represent more precisely the behavior of the electrical system. Below are the results from different systems:

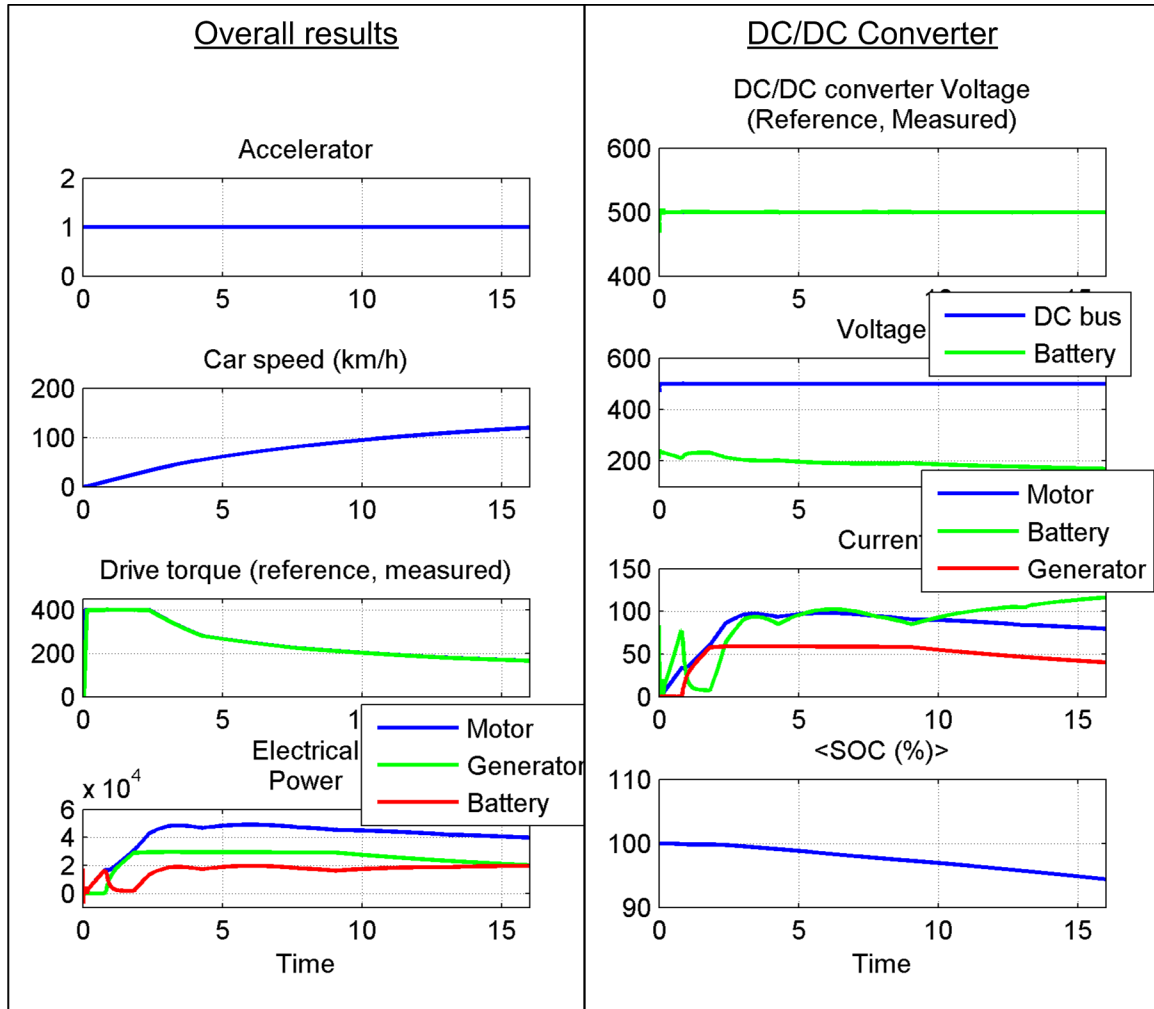

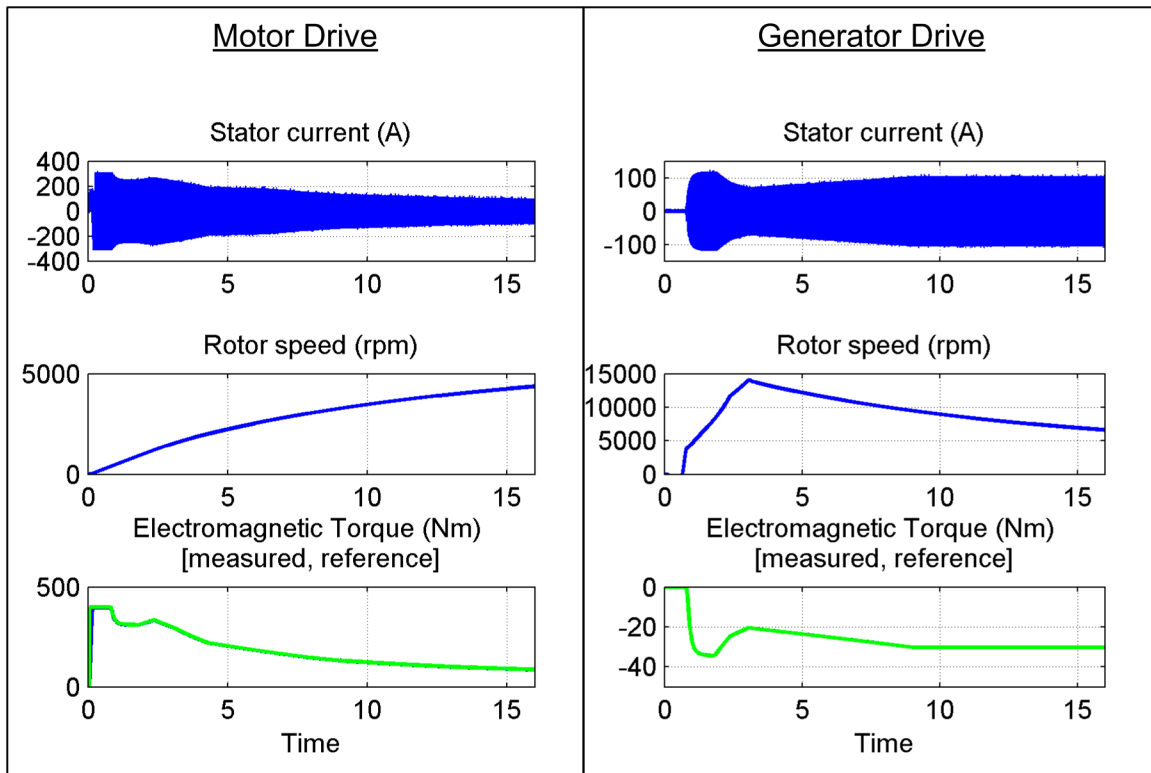

The Detailed Model

In this phase of modeling, the average value models of converters are replaced by power semiconductor switches. A method to generate the pulse width modulated (PWM) signals is also determined.

The DC/DC Converter

For the detailed model of the DC/DC converter, the output of the PI controller is sent to the pulse width modulator, which selects the pulse sequence required to maintain the DC bus voltage close to the reference value. The PWM signals are then sent directly to the single leg power semiconductor switch.

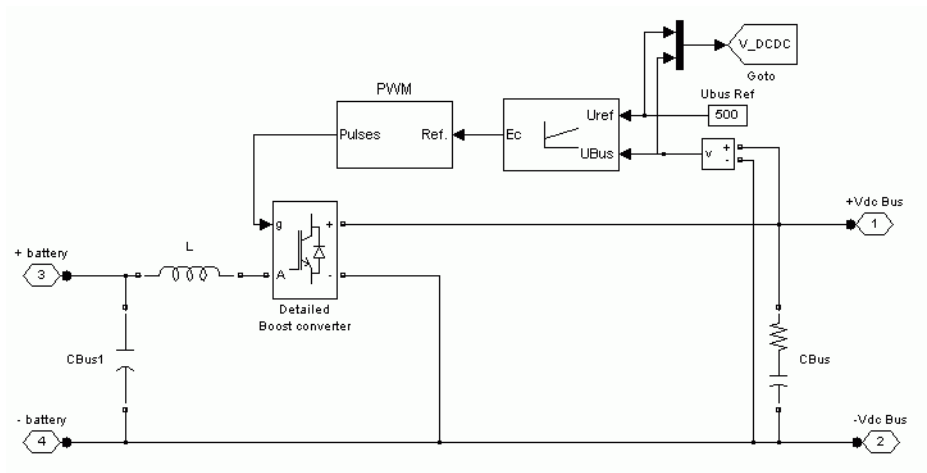

The Motor and the Generator Drives

For the detailed model of these elements, the average value inverter is replaced by a 3 legs power semiconductor switches consisting of 6 pairs of IGBT/diode. The output signal of the vector controller is sent to the hysteresis controller, which generates the required PWM signals. For more information about these systems see the PM Synchronous Motor Drive.

Simulation Results

The simulation of the detailed model gives a lot of information regarding the power converters. In fact, it allows the selection of the PWM generation method, the adjustment of the switching frequency (for the DC/DC converter) and the tuning of the hysteresis band of the current regulator necessary for vector control (motor and generator). Moreover, it allows the dimensioning of the converters as the instantaneous values of currents are accurately known. The selection of power semiconductor switches and the dimensioning of heat sinks can be made afterwards.

In a broader view, this simulation helps to validate with a high precision the operation of the electrical circuit and allows the detection of any problems caused by instability, over voltage or over current. This high degree of precision is obtained of course, at the price of a longer calculation time. In fact, the simulation time is around 90 times the real time in accelerator mode. Below are the results from different systems:

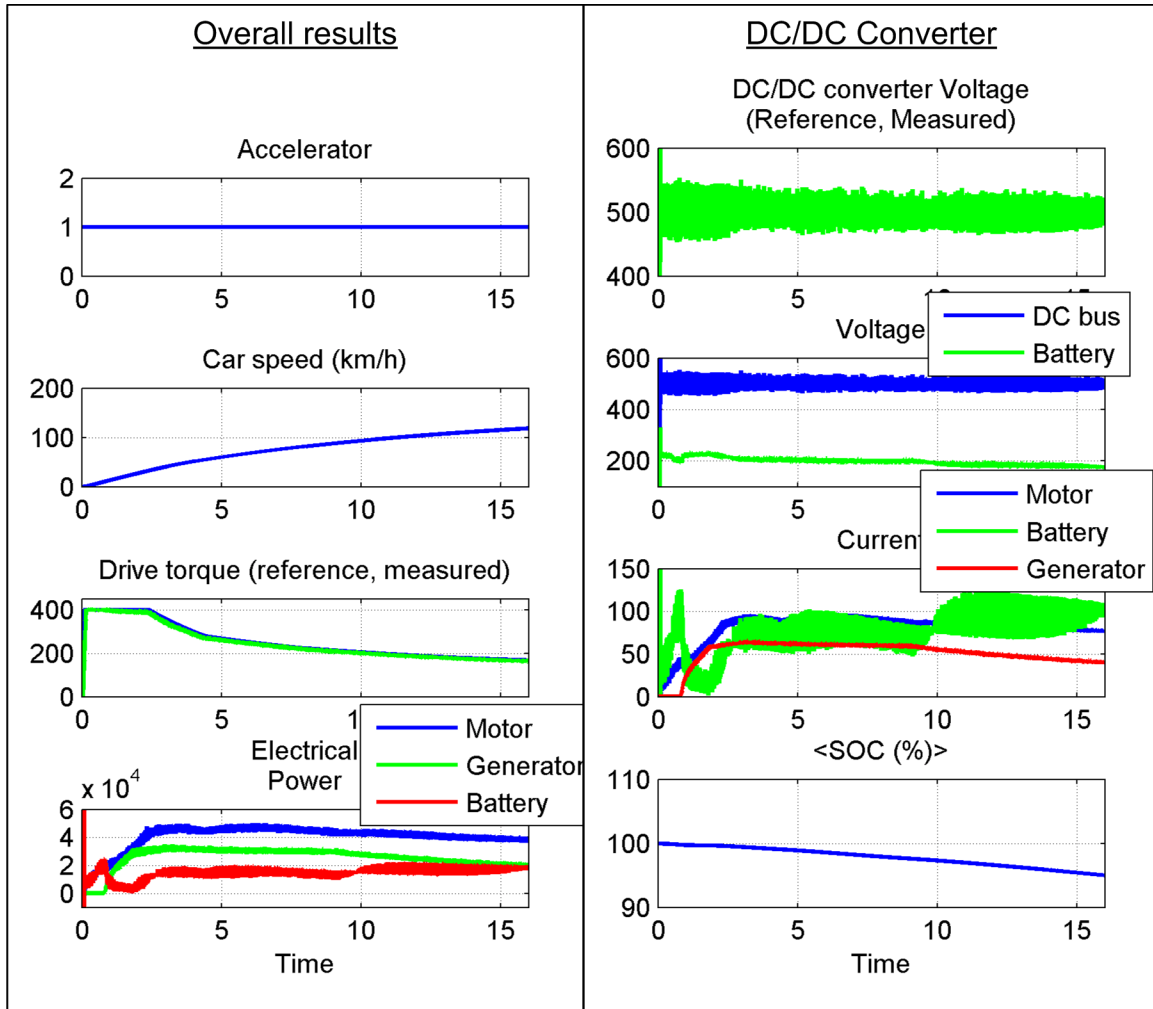

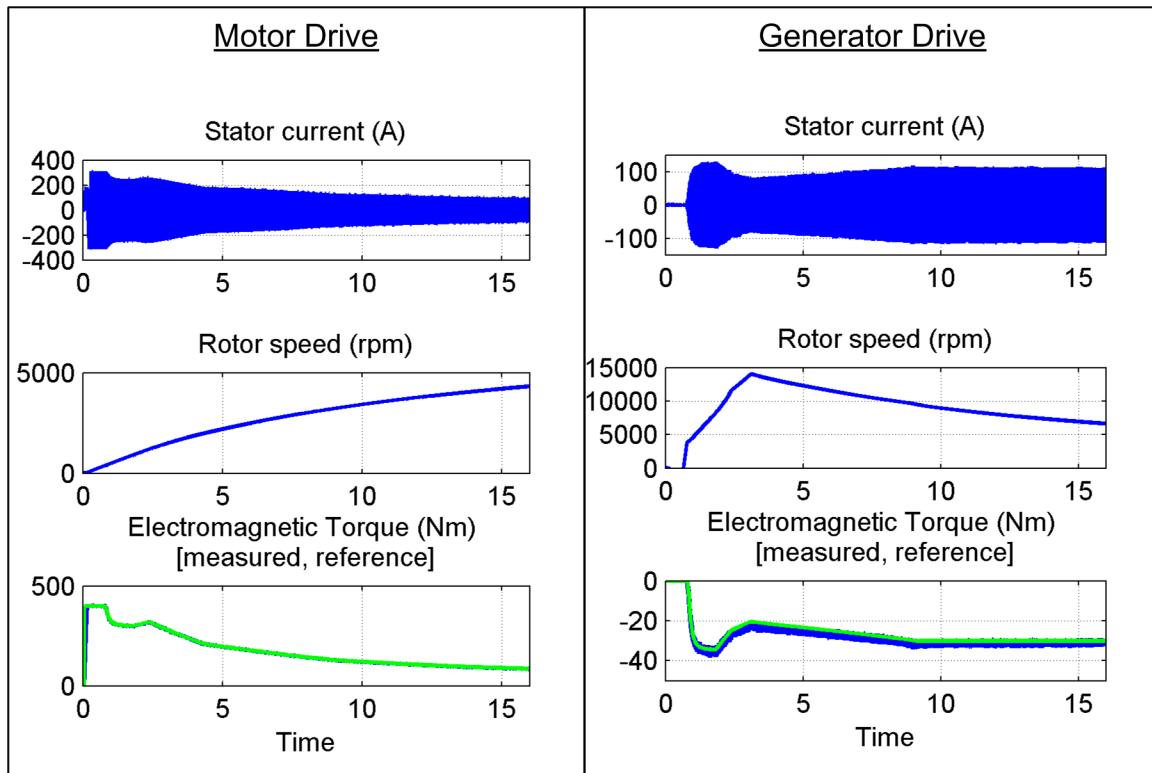

Comparison of the Multi-Level Modeling Precision

Regarding the precision, the mechanical signals (the vehicle speed and torque) and the electrical signals (the average power from different elements) are very close for all the three models. In fact, the error on the vehicle speed is less than 2 Km/h and 1.5 Km/h for the simplified and the average value models respectively. Regarding the motor power, the dynamics of the simplified and average value models are also close to the detailed model. The main difference resides on the high frequency component present on the detailed model signals due to the switching frequency of the inverter. The maximum error from the two models is less than 5000 W (below 10%) and the average error is below 5%.

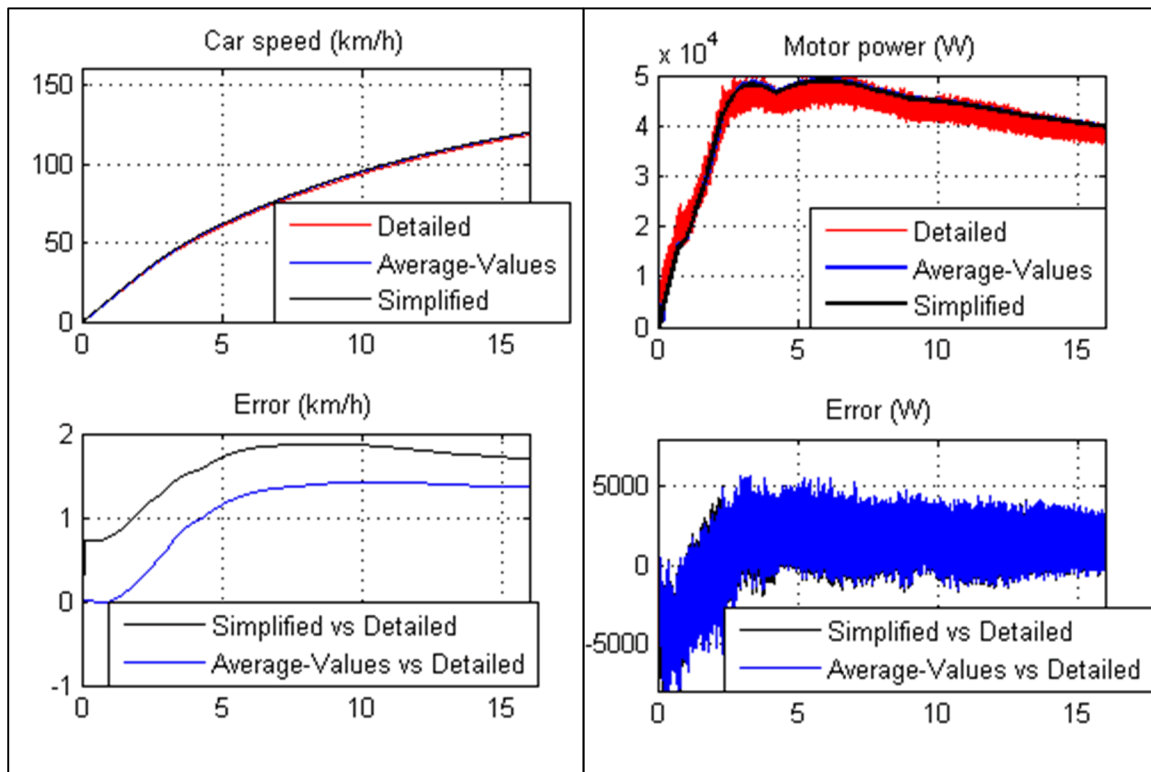

Regarding the vehicle torque, the three models are very close with a maximum error of 5%. By closely looking at the differences (right figure), it is noted that the simplified model reacts instantaneously to the reference torque required by the energy management system. For the average value model, the torque increases progressively to the desired torque with a greater accuracy compared to the detailed model. Again, the detailed model is characterized by the high frequency signal generated by the switching frequency of the electrical system.

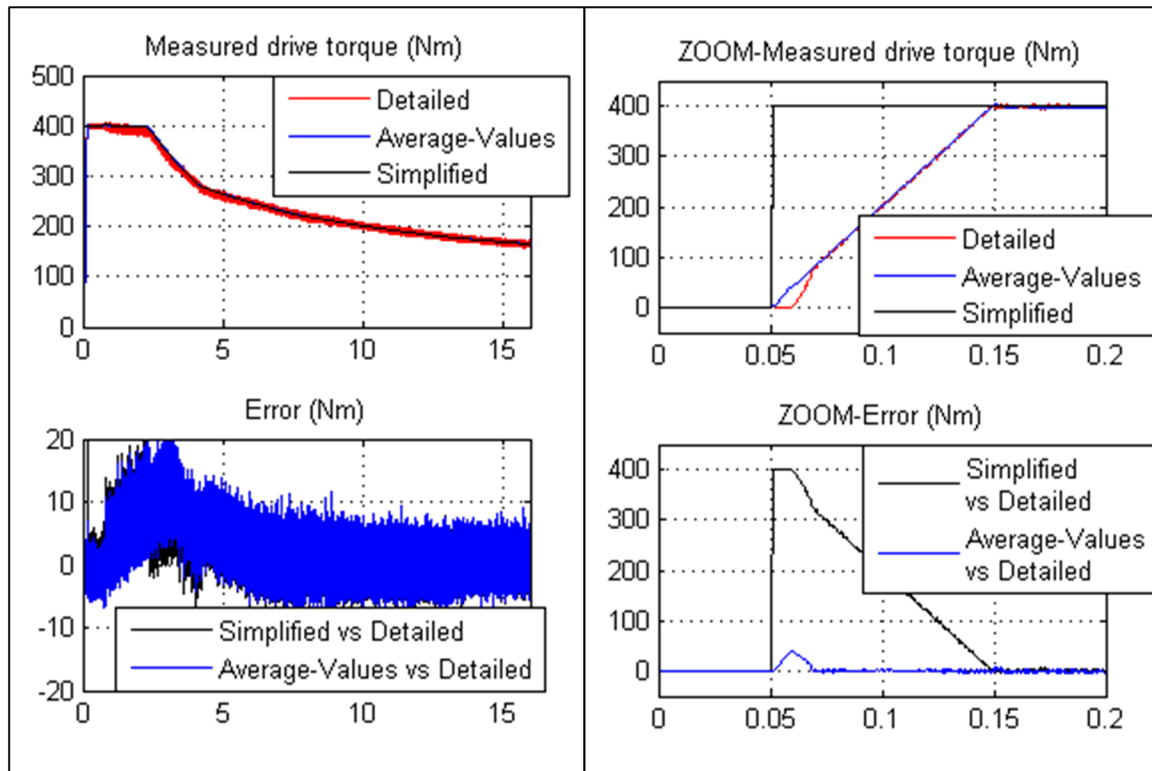

As for the battery signals, the simplified and the average value models follow exactly the dynamics of the detailed model with no high frequency component.

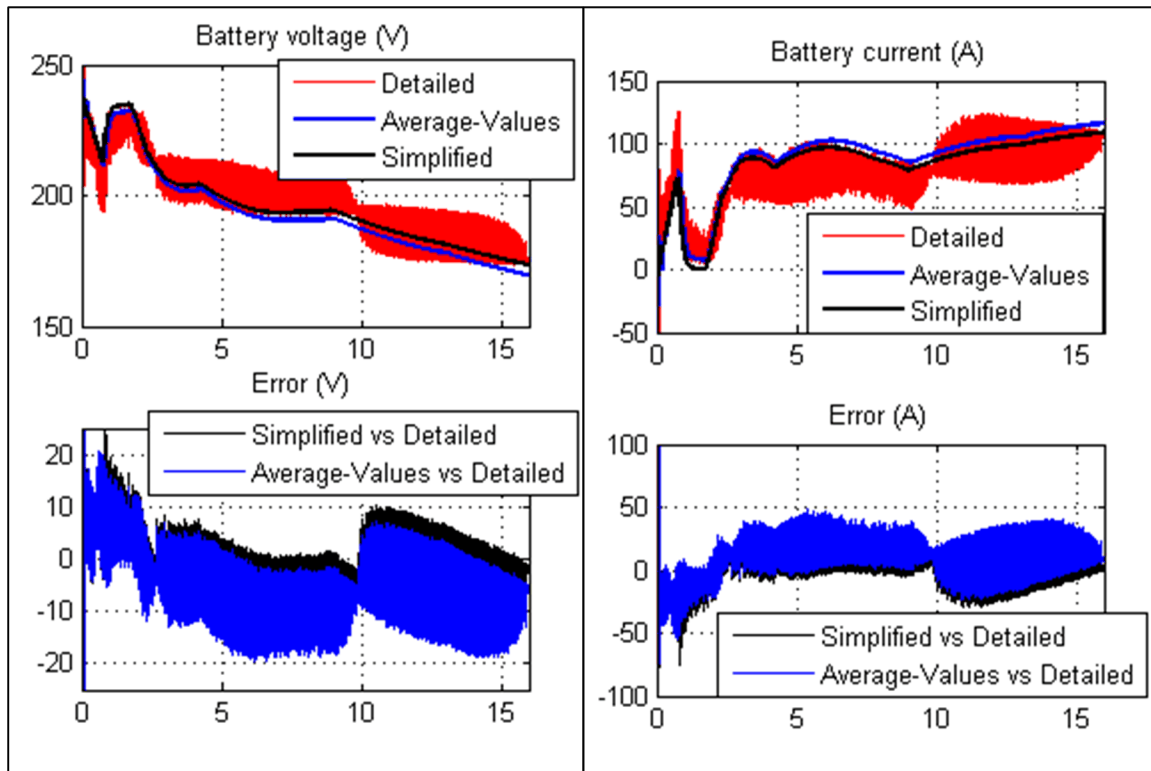

One of the main differences between the simplified and the average value models resides on the electrical signals from the motor and the generator. In fact, the simplified model can not represent the motor or the generator current. The difference between the average value and the detailed models is the presence of the high frequency component on the detailed model. The amplitude of currents is exactly the same for the two models whereas the phase could be different due to variations on the mechanical speed.

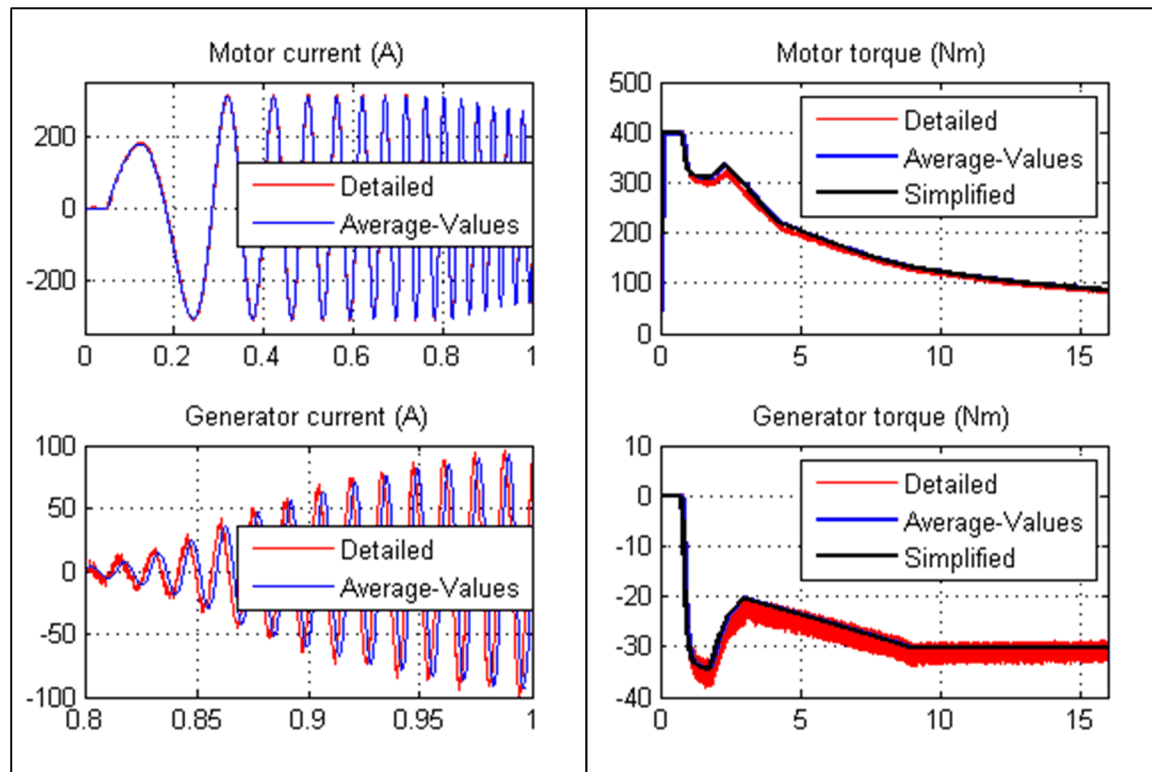

Here is a table which summarizes the differences between the different detailed levels:

	Simplified	Average	Detailed
Simulation time (s)	11 (normal)	56 (accelerator) 256 (normal)	1440 (accelerator)
Mechanical dynamics	yes	yes	yes
DC bus voltage dynamics	no	yes	yes
Electrical Motor/Generator stator currents	no	yes	yes
Electrical power losses	no	yes	yes
High frequency harmonics	no	no	yes

Conclusion

To conclude, the level of precision chosen depends on the stage of development the engineer is working on. For example, at the beginning of the process, the system engineer wants to simulate its system to have an idea on how it operates, with the objective to effectively adjust the energy management system. The simulation of the simplified model helps to determine the speeds, torques and electrical powers present in the system. As this model requires less calculation time (less than 1 times the real time), it is possible to study several configurations and obtain results close to reality in a very short time.

Subsequently, the average value model allows the electrical engineer to design different control systems and to select the motor and the generator based on the results from the simplified model. The simulation time (less than 4 times the real time in accelerator mode) is acceptable. It allows the validation of the system behavior and the adjustment of both the control system and the energy management system.

Finally, the specialist in power electronics can use the detailed model to select the power semiconductors components based on the instantaneous and average values of currents and voltages. The losses can be evaluated (for heat sink design), the switching frequency can be adjusted in order to assure the electromagnetic interference (EMI) will not affect other systems. Moreover, the complete simulation of the detailed model allows to validate the behavior of different elements in the system and to fine tune the energy management system if necessary. Of course, this high level of accuracy comes with a larger calculation time, around 90 times the real time. But this large time is still acceptable if compared with the time required in an experimental setup.

Obviously, in the development of the detailed or the average value model, it is possible to isolate some blocks, such as the DC/DC converter or the motor and generator drives in order to preliminary adjust each system. The block can be added to the complete model when it operates properly.

Finally, when the simulation model is completed, it represents the reality with a high degree of accuracy. The next phase, which consists of the realization of the system experimentally, can be made with less time and at lower cost.

Transients and Power Electronics in Power Systems

These case studies provide detailed, realistic examples of how to use SimPowerSystems software in typical power utility applications. All these examples use fixed-step discretized models. Case 1 shows a study of transients in an AC series-compensated transmission system. Cases 2 to 5 show examples of power-electronics based flexible AC transmission systems (FACTS) and cover two typical areas of FACTS applications:

- Cases 2 and 3 illustrate shunt reactive power compensation using two different technologies: a SVC using thyristors and a STATCOM using a square-wave GTO voltage-sourced converter.
- Cases 4 and 5 illustrate two technologies of power conversion for HVDC transmission: thyristor converters and pulse width modulation (PWM) voltage-sourced converters.
- “Series-Compensated Transmission System” on page 5-2
- “Thyristor-Based Static Var Compensator” on page 5-19
- “GTO-Based STATCOM” on page 5-28
- “Thyristor-Based HVDC Link” on page 5-38
- “VSC-Based HVDC Link” on page 5-57

Series-Compensated Transmission System

In this section...

“Description of the Transmission System” on page 5-2

“Setting the Initial Load Flow and Obtaining Steady State” on page 5-8

“Transient Performance for a Line Fault” on page 5-9

“Frequency Analysis” on page 5-13

“Transient Performance for a Fault at Bus B2” on page 5-16

Description of the Transmission System

The example described in this section illustrates modeling of series compensation and related phenomena such as subsynchronous resonance in a transmission system.

The single-line diagram shown here represents a three-phase, 60 Hz, 735 kV power system transmitting power from a power plant consisting of six 350 MVA generators to an equivalent system through a 600 km transmission line. The transmission line is split into two 300 km lines connected between buses B1, B2, and B3.

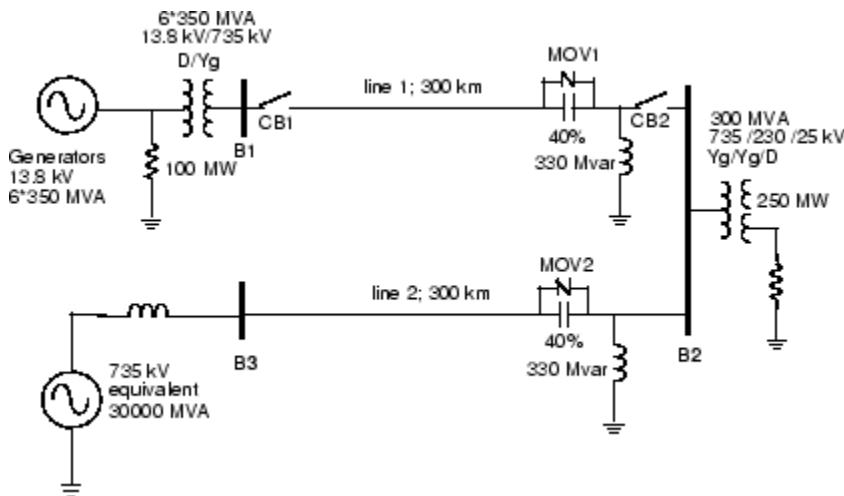

Series and Shunt Compensated Transmission System

To increase the transmission capacity, each line is series compensated by capacitors representing 40% of the line reactance. Both lines are also shunt compensated by a 330 Mvar shunt reactance. The shunt and series compensation equipment is located at the B2 substation where a 300 MVA-735/230 kV transformer feeds a 230 kV-250 MW load.

Each series compensation bank is protected by metal-oxide varistors (MOV1 and MOV2). The two circuit breakers of line 1 are shown as CB1 and CB2.

This power system is available in the power_3phseriescomp model. Load this model and save it in your working directory as **case1** to allow further modifications to the original system.

Compare the SimPowerSystems circuit model (Series-Compensated System (power_3phseriescomp)) with the schematic diagram above (Series and Shunt Compensated Transmission System). The generators are simulated with a **Simplified Synchronous Machine** block. A **Three-Phase Transformer (Two Windings)** block and a **Three-Phase Transformer (Three Windings)** block are used to model the two transformers. Saturation is implemented on the transformer connected at bus B2.

The B1, B2, and B3 blocks are **Three-Phase V-I Measurement** blocks taken from the Measurements library. These blocks are reformatted and given a black background color to give them the appearance of bus bars. They output the three line-to-ground voltages and the three line currents. Open the dialog boxes of B1 and B2. Note how the blocks are programmed to output voltages in pu and currents in pu/100 MVA. Notice also that the voltage and current signals are sent to internal Goto blocks by specifying signal labels. The signals are picked up by the From blocks in the Data Acquisition subsystem.

The fault is applied on line 1, on the line side of the capacitor bank. Open the dialog boxes of the **Three-Phase Fault** block and of the **Three-Phase Breaker** blocks CB1 and CB2. See how the initial breaker status and switching times are specified. A line-to-ground fault is applied on phase A at $t = 1$ cycle. The two circuit breakers that are initially closed are then open at $t = 5$ cycles, simulating a fault detection and opening time of 4 cycles. The fault is eliminated at $t = 6$ cycles, one cycle after the line opening.

735 kV Series Compensated Transmission System

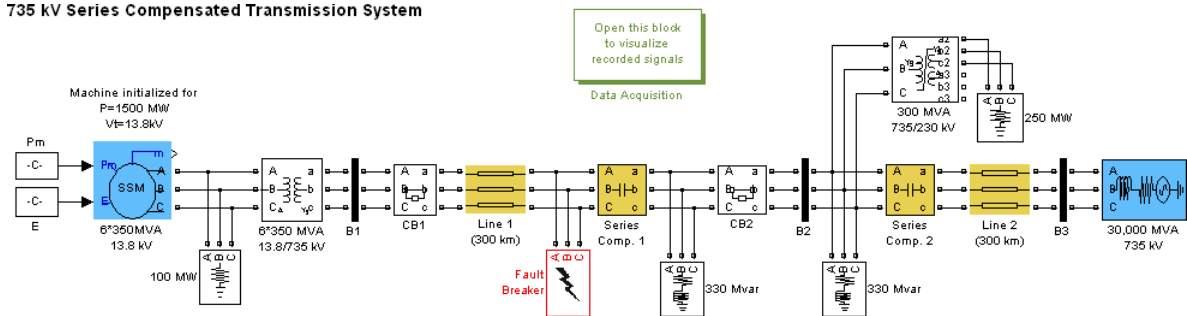

Series-Compensated System (power_3phseriescomp)

Series Compensation1 Subsystem

Now, open the Series Compensation1 subsystem of the power_3phseriescomp model. The three-phase module consists of three identical subsystems, one for each phase. A note indicates how the capacitance value and the MOV protection level are calculated. Open the Series Compensation1/Phase A subsystem. You can see the details of the connections of the series capacitor and the Surge Arrester block (renamed MOV). The transmission line is 40% series compensated by a $62.8 \mu\text{F}$ capacitor. The capacitor is protected by the MOV block. If you open the dialog box of the MOV block, notice that it consists of 60 columns and that its protection level (specified at a reference current of 500 A/column or 30 kA total) is set at 298.7 kV. This voltage corresponds to 2.5 times the nominal capacitor voltage obtained at a nominal current of 2 kA RMS.

A gap is also connected in parallel with the MOV block. The gap is fired when the energy absorbed by the surge arrester exceeds a critical value of 30 MJ. To limit the rate of rise of capacitor current when the gap is fired, a damping RL circuit is connected in series. Open the Energy & Gap firing subsystem. It shows how you calculate the energy dissipated in the MOV by integrating the power (product of the MOV voltage and current).

When the energy exceeds the 30 MJ threshold, a closing order is sent to the Breaker block simulating the gap.

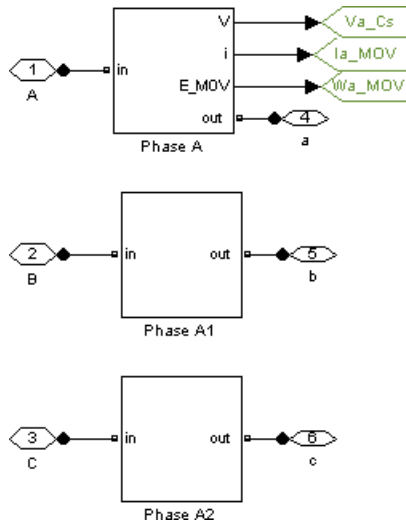

Series Compensation Module

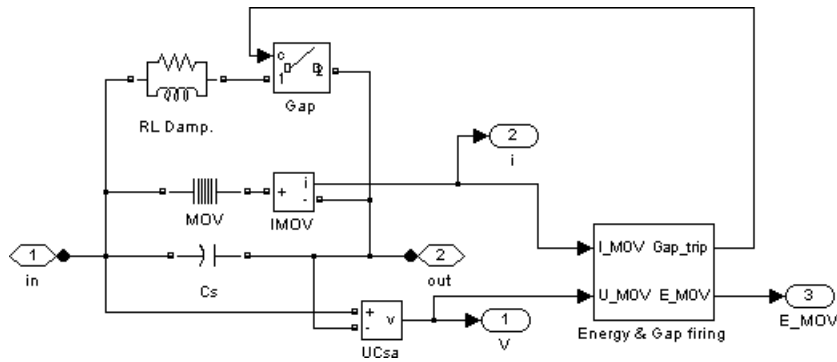

Series Compensation 1/PhaseA Subsystem

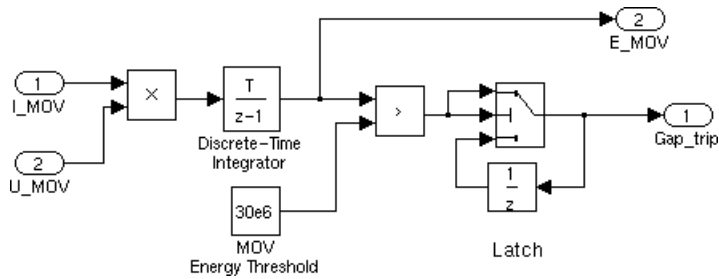

Series Compensation 1/PhaseA Subsystem/Energy and Gap Firing

Three-Phase Saturable Transformer Model

Open the **300 MVA 735/230 kV Transformer** dialog box and notice that the current-flux saturation characteristic is set at

[0 0 ; 0.0012 1.2; 1 1.45] in pu

These data are the current and flux values at points 1, 2, and 3 of the piecewise linear approximation to the flux linkage curve shown here.

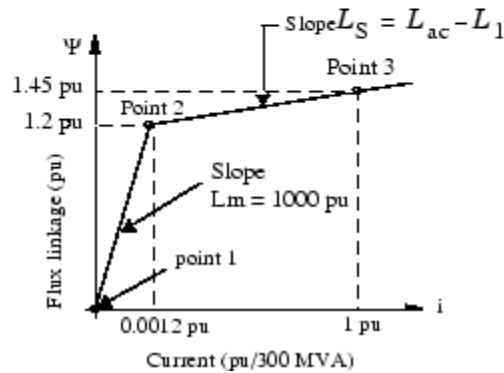
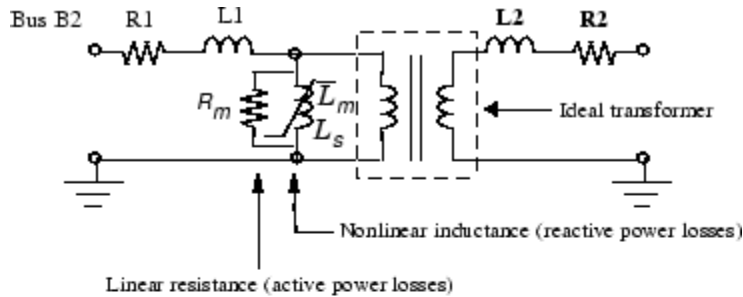

Saturable Transformer Model

The flux-current characteristic is approximated by the two segments shown in the graph here. The saturation knee point is 1.2 pu. The first segment corresponds to the magnetizing characteristic in the linear region (for fluxes below 1.2 pu). At 1 pu voltage, the inductive magnetizing current is $0.0010/1.0 = 0.001$ pu, corresponding to 0.1% reactive power losses.

The iron core losses (active power losses) are specified by the magnetization resistance $R_m = 1000$ pu, corresponding to 0.1% losses at nominal voltage.

The slope of the saturation characteristic in the saturated region is 0.25 pu. Therefore, taking into account the primary leakage reactance ($L_1 = 0.15$ pu), the air core reactance of the transformer seen from the primary winding is 0.4 pu/300 MVA.

Setting the Initial Load Flow and Obtaining Steady State

Before performing transient tests, you must initialize your model for the desired load flow. Use the load flow utility of the Powergui to obtain an active power flow of 1500 MW out of the machine with a terminal voltage of 1 pu (13.8 kV).

Open the Powergui block and select **Machine Initialization**. A new window appears. In the upper right window you have the name of the only machine present in your system. Its **Bus type** should be **PV Generator** and the desired **Terminal Voltage** should already be set to the nominal voltage of **13800 V**. In the **Active Power** field, enter **1500e6** as the desired output power. Click the **Compute and Apply** button. Once the load flow is solved, the phasors of AB and BC machine voltages as well as currents flowing in phases A and B are updated in the left window. The required mechanical power to drive the machine is displayed in watts and in pu, and the required excitation voltage E is displayed in pu.

Pmec	1.5159e9 W [0.72184 pu]
E/Vf	1.0075 pu

Notice that Constant blocks containing these two values are already connected to the Pm and E inputs of the machine block. If you open the Machine block dialog box, you see that the machine initial conditions (initial speed deviation $dw = 0$; internal angle theta, current magnitudes, and phase angles) are automatically transferred in the last line.

Once the load flow is performed, you can obtain the corresponding voltage and current measurements at the different buses. In the Powergui block, select **Steady State Voltages and Currents**. You can observe, for example, the phasors for phase A voltages at buses B1, B2, and B3 and the current entering line 1 at bus B1.

B1/Va	6.088e5 V ; 18.22 degrees
B2/Va	6.223e5 V ; 9.26 degrees
B3/Va	6.064e5 V ; 2.04 degrees
B1/Ia	1560 A ; 30.50 degrees

The active power flow for phase A entering line 1 is therefore

$$P_a = V_a \cdot I_a \cdot \cos(\varphi_a) = \frac{608.8 \text{ kV}}{\sqrt{2}} \cdot \frac{1.56 \text{ kA}}{\sqrt{2}} \cdot \cos(30.50 - 18.22) = 464 \text{ MW}$$

corresponding to a total of $464 * 3 = 1392$ MW for the three phases.

Transient Performance for a Line Fault

To speed up the simulation, you need to discretize the power system. The sample time is specified in the `Powergui` block as a variable `Ts`. The sample time `Ts=50e-6` has already been defined in the Model Initialization function in the Callbacks of the Model Properties. The sample time `Ts` is also used in the Discrete Integrator block of the MOV energy calculator controlling the gap.

Ensure that the simulation parameters are set as follows.

Stop time	0.2
Solver options type	Fixed-step; discrete (no continuous state)
Fixed step size	Ts

Line-to-Ground Fault Applied on Line 1

Ensure that the fault breaker is programmed for a line-to-ground fault on phase A. Start the simulation and observe the waveforms on the three scopes. These waveforms are shown here.

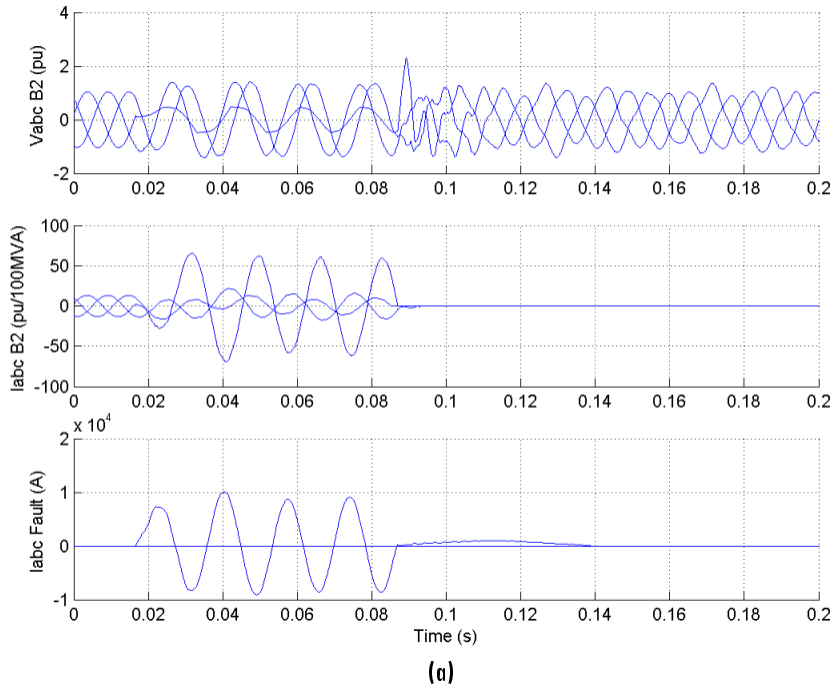

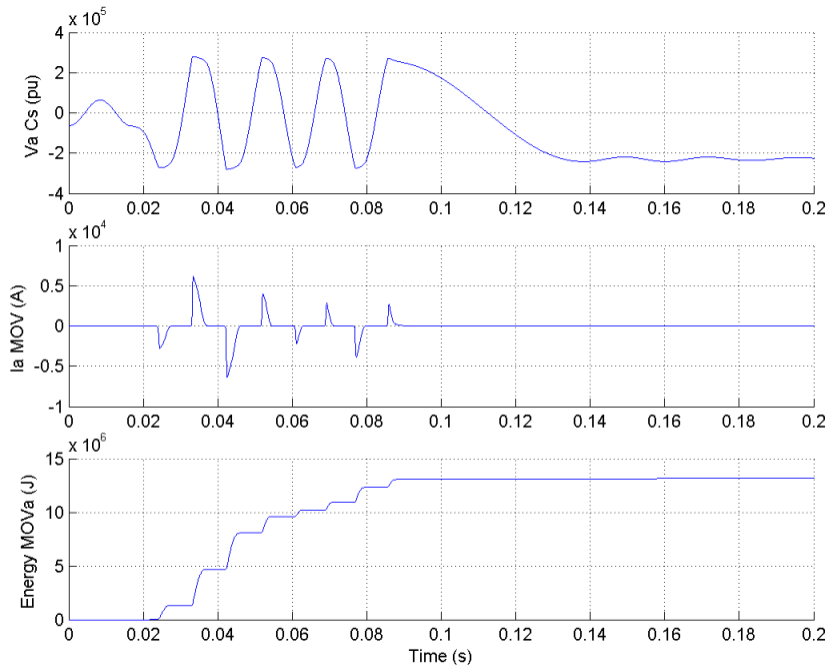

(b)

Simulation Results for a Four-Cycle Line-to-Ground Fault at the End of Line 1

The simulation starts in steady state. At the $t = 1$ cycle, a line-to-ground fault is applied and the fault current reaches 10 kA (a: trace 3). During the fault, the MOV conducts at every half cycle (b: trace 2) and the energy dissipated in the MOV (b: trace 3) builds up to 13 MJ. At $t = 5$ cycles the line protection relays open breakers CB1 and CB2 (see the three line currents on trace 2) and the energy stays constant at 13 MJ. As the maximum energy does not exceed the 30 MJ threshold level, the gap is not fired. At the breaker opening, the fault current drops to a small value and the line and series capacitance starts to discharge through the fault and the shunt reactance. The fault current extinguishes at the first zero crossing after the opening order given to the fault breaker ($t = 6$ cycles). Then the series capacitor stops discharging and its voltage oscillates around 220 kV (b: trace 1).

Three-Phase-to-Ground Fault Applied on Line 1

Double-click the Three-Phase Fault block to open the **Block Parameters** dialog box. Select the **Phase B Fault** and **Phase C Fault** check boxes, so that you now have a three-phase-to-ground fault.

Restart the simulation. The resulting waveforms are shown.

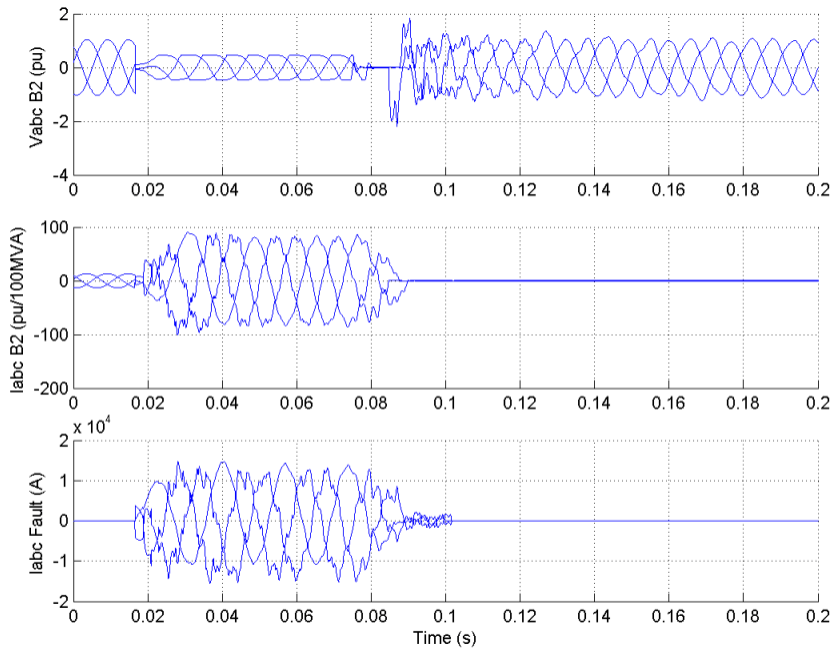

(a)

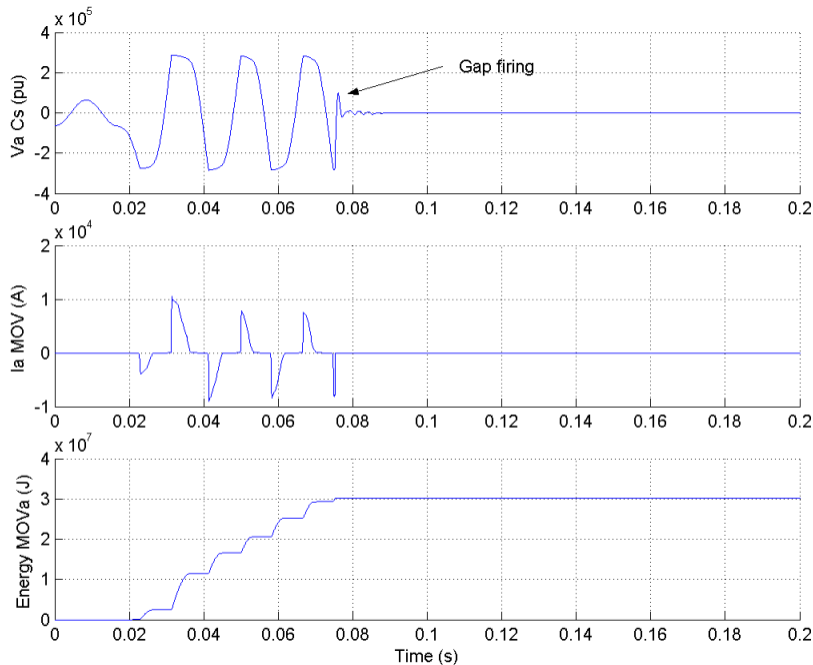

(b)

Simulation Results for a Four-Cycle Three-Phase-to-Ground Fault at the End of Line 1

Note that during the fault the energy dissipated in the MOV (b: trace 3) builds up faster than in the case of a line-to-ground fault. The energy reaches the 30 MJ threshold level after three cycles, one cycle before the opening of the line breakers. As a result, the gap is fired and the capacitor voltage (b: trace 1) quickly discharges to zero through the damping circuit.

Frequency Analysis

One particular characteristic of series-compensated systems is the existence of subsynchronous modes (poles and zeros of the system impedance below the fundamental frequency). Dangerous resonances can occur if the mechanical torsion modes of turbine/generator shafts are in the vicinity of the zeros of the system impedance. Also, high subsynchronous voltages due to impedance poles at subsynchronous frequencies drive transformers into saturation. The transformer saturation due to subsynchronous

voltages is illustrated at the end of this case study. The torque amplification on a thermal machine is illustrated in another example (see the `power_thermal` model).

Now measure the positive-sequence impedance versus frequency seen from bus B2.

The section “Analyze a Simple Circuit” on page 1-12 explains how the **Impedance Measurement** block allows you to compute the impedance of a linear system from its state-space model. However, your `case1` model contains several nonlinear blocks (machine and saturation of transformers). If you connect the Impedance Measurement block to your system, all nonlinear blocks are ignored. This is correct for the transformer, but you get the impedance of the system with the machine disconnected. Before measuring the impedance, you must therefore replace the machine block with an equivalent linear block having the same impedance.

Delete the Simplified Synchronous Machine block from your `case1` model and replace it with the **Three-Phase Source** block from the Electrical Sources library. Open the block dialog box and set the parameters as follows to get the same impedance value ($L = 0.22$ pu / ($6 * 350$ MVA) Quality factor = 15).

Phase-to-phase rms voltage	13.8e3
Phase angle of phase A	0
Frequency (Hz)	60
Internal connection Yg	Specify impedance using short-circuit level
3-phase short-circuit level	6*350e6
Base voltage	13.8e3
X/R ratio	15

Save your modified model as `case1Zf`.

Open the Fundamental Blocks/Measurements library and copy the Impedance Measurement block into your model. This block is used to perform the impedance measurement. Connect the two inputs of this block between phase A and phase B of the B2 bus. Measuring the impedance between two phases gives two times the positive-sequence impedance. Therefore you must apply a factor of 1/2 to the impedance to obtain the correct impedance value. Open the dialog box and set the multiplication factor to 0.5.

In the Powergui block, select **Impedance Measurement**. A new window opens, showing your Impedance Measurement block name. Fill in the frequency range by entering

0:500. Select the linear scales to display Z magnitude vs. frequency plot. Click the **Save data to workspace** button and enter **Zcase1** as the variable name to contain the impedance vs. frequency. Click the **Display** button.

When the calculation is finished, the magnitude and phase as a function of frequency are displayed in the two graphs on the window. If you look in your workspace, you should have a variable named **Zcase1**. It is a two-column matrix containing frequency in column 1 and complex impedance in column 2.

The impedance as a function of frequency (magnitude and phase) is shown here.

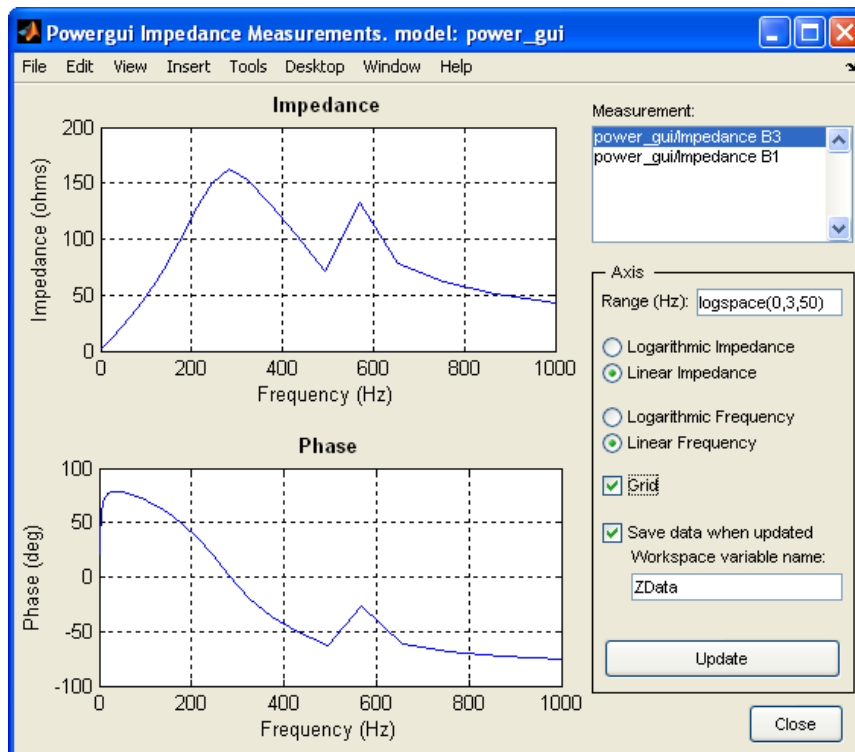

Impedance vs. Frequency Seen from Bus B2

You can observe three main modes: 9 Hz, 175 Hz, and 370 Hz. The 9 Hz mode is mainly due to a parallel resonance of the series capacitor with the shunt inductors. The 175 Hz

and 370 Hz modes are due to the 600 km distributed parameter line. These three modes are likely to be excited at fault clearing.

If you zoom in on the impedance in the 60 Hz region, you can find the system's short-circuit level at bus B2. You should find a value of 58 Ω at 60 Hz, corresponding to a three-phase short-circuit power of $(735 \text{ kV})^2 / 58 = 9314 \text{ MVA}$.

Transient Performance for a Fault at Bus B2

The configuration of the substation circuit breakers normally allows clearing a fault at the bus without losing the lines or the transformers. You now modify your `case1` model to perform a three-cycle, three-phase-to-ground fault at bus B2:

- 1 Disconnect the Three-Phase Fault block and reconnect it so that the fault is now applied on bus B2.
- 2 Open the Three-Phase Fault block and make the following modifications in its dialog box:

Phase A, Phase B, Phase C, Ground Faults	All selected
Transition times	[2/60 5/60]
Transition status [1, 0, 1...]	(0/1)

You have now programmed a three-phase-to-ground fault applied at the $t = 2$ cycles.

- 3 Open the dialog boxes of circuit breakers CB1 and CB2 and make the following modifications:

Switching of Phase A	Not selected
Switching of Phase B	Not selected
Switching of Phase C	Not selected

The circuit breakers are not switched anymore. They stay at their initial state (closed).

- 4 In the Data Acquisition subsystem, insert a Selector block (from the Simulink Signals & Systems library) in the `Vabc_B2` output of bus B2 connected to the scope. Set the **Elements** parameter to 1. This allows you to see the phase A voltage clearly on the scope.

- 5 You now add blocks to read the flux and the magnetization current of the saturable transformer connected at bus B2.

Copy the **Multimeter** block from the Measurements library into your **case1** model. Open the **Transformer** dialog box. In the **Measurements** list, select **Flux** and **magnetization current**. Open the Multimeter block. Verify that you have six signals available. Select flux and magnetization current on phase A, and click **OK**.

- 6 You now have two signals available at the output of the Multimeter block. Use a Demux block to send these two signals on a two-trace scope.
- 7 In the **Simulation > Model Configuration Parameters** dialog box, change the stop time to **0.5**. This longer simulation time allows you to observe the expected low-frequency modes (9 Hz). Start the simulation.

The resulting waveforms are plotted here.

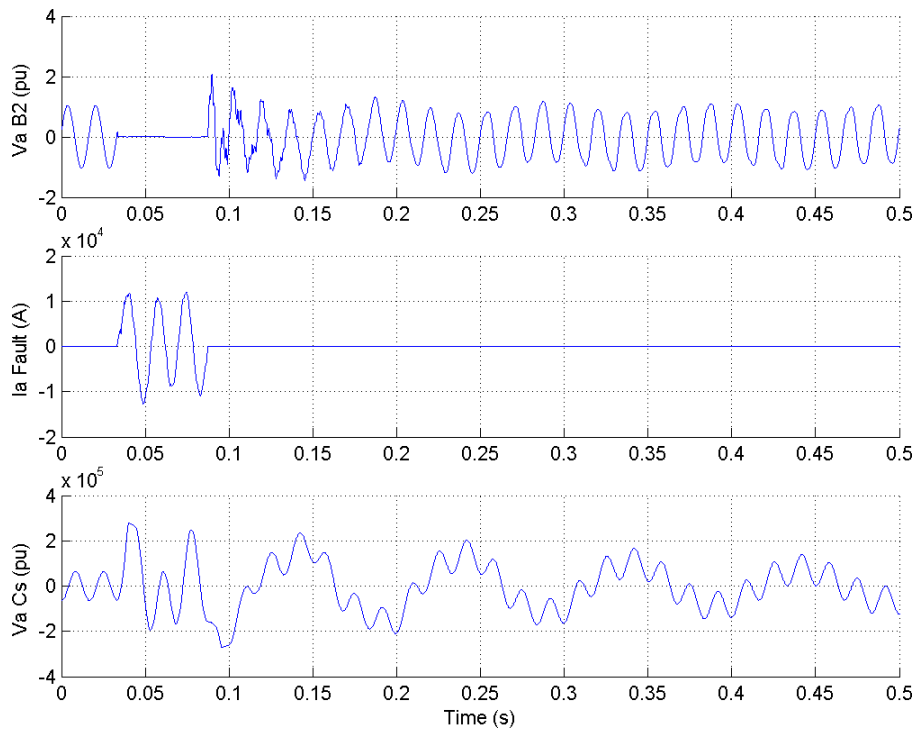

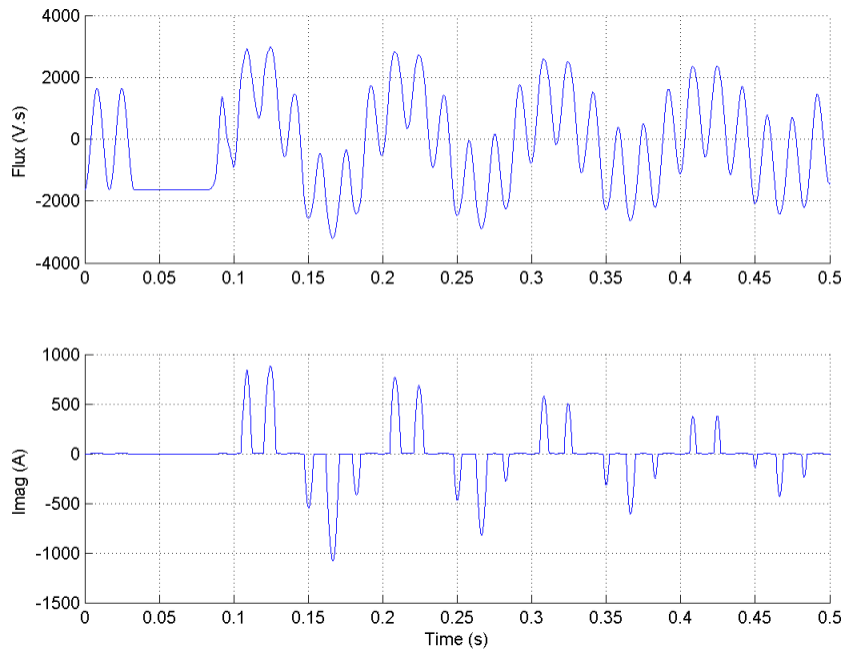

Simulation Results for a Three-Cycle Three-Phase-to-Ground Fault at BusB2

The 9 Hz subsynchronous mode excited at fault clearing is clearly seen on the phase A voltage at bus B2 (trace 1) and capacitor voltage (trace 3). The 9 Hz voltage component appearing at bus B2 drives the transformer into saturation, as shown on the transformer magnetizing current (trace 5). The flux in phase A of the transformer is plotted on trace 4. At fault application the voltage at transformer terminals drops to zero and the flux stays constant during the fault.

At fault clearing, when the voltage recovers, the transformer is driven into saturation as a result of the flux offset created by the 60 Hz and 9 Hz voltage components. The pulses of the transformer magnetizing current appear when the flux exceeds its saturation level. This current contains a 60 Hz reactive component modulated at 9 Hz.

Thyristor-Based Static Var Compensator

In this section...

“Introduction” on page 5-19

“Description of the SVC” on page 5-19

“Steady-State and Dynamic Performance of the SVC” on page 5-23

“Misfiring of TSC1” on page 5-25

Introduction

The example described in this section illustrates application of SimPowerSystems software to study the steady-state and dynamic performance of a static var compensator (SVC) on a transmission system. The SVC is a shunt device of the Flexible AC Transmission Systems (FACTS) family using power electronics. It regulates voltage by generating or absorbing reactive power. If you are not familiar with the SVC, see the **Static Var Compensator (Phasor Type)** block documentation, which describes the SVC principle of operation.

The Static Var Compensator (Phasor Type) block of the FACTS library is a simplified model that can simulate any SVC topology. You can use it with the phasor simulation option of the **Powergui** block for studying dynamic performance and transient stability of power systems. Due to low frequencies of electromechanical oscillations in large power systems (typically 0.02 Hz to 2 Hz), this type of study usually requires simulation times of 30–40 seconds or more.

The SVC model described in this example is rather a detailed model of a particular SVC topology (using thyristor-controlled reactor (TCR) and thyristor-switched capacitors (TSCs)) with full representation of power electronics. This type of model requires discrete simulation at fixed time steps (50 μ s in this case) and it is used typically for studying the SVC performance on a much smaller time range (a few seconds). Typical applications include optimizing of the control system, impact of harmonics, transients and stresses on power components during faults.

Description of the SVC

The single-line diagram of the modeled SVC is shown on **Single-Line Diagram of the SVC**. It represents a 300 Mvar SVC connected on a 735 kV transmission system.

This example is available in the `power_svc_1tcr3tsc` model. Load this model and save it in your working directory as `case2` to allow further modifications to the original system. This model is shown on SPS Model of the 300 Mvar SVC on a 735 kV Power System (`power_svc_1tcr3tscs`).

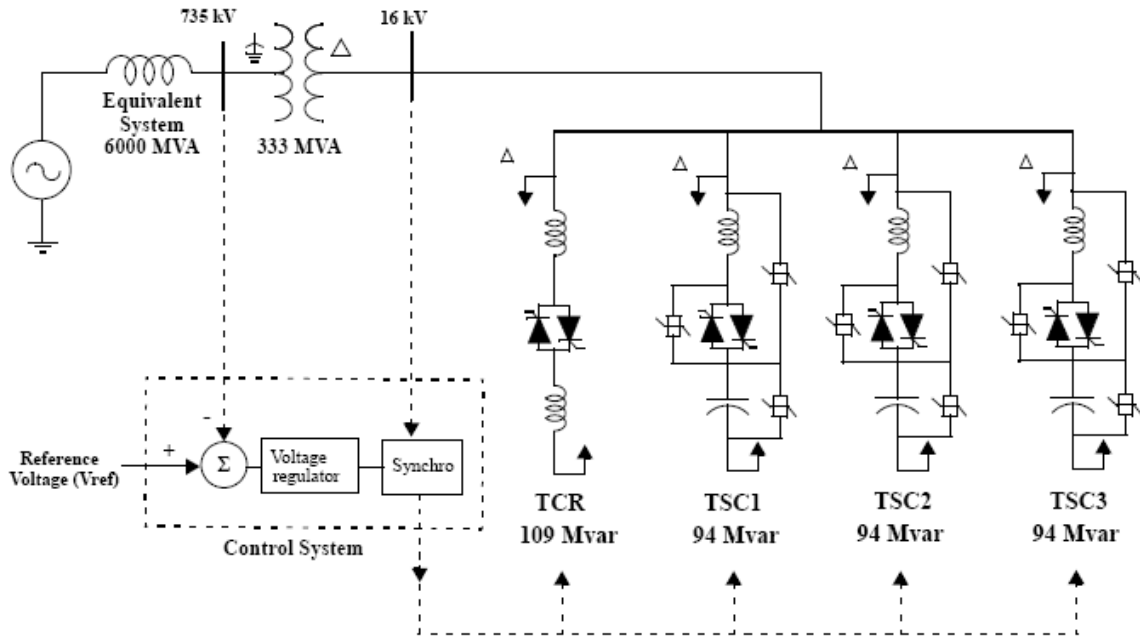

Single-Line Diagram of the SVC

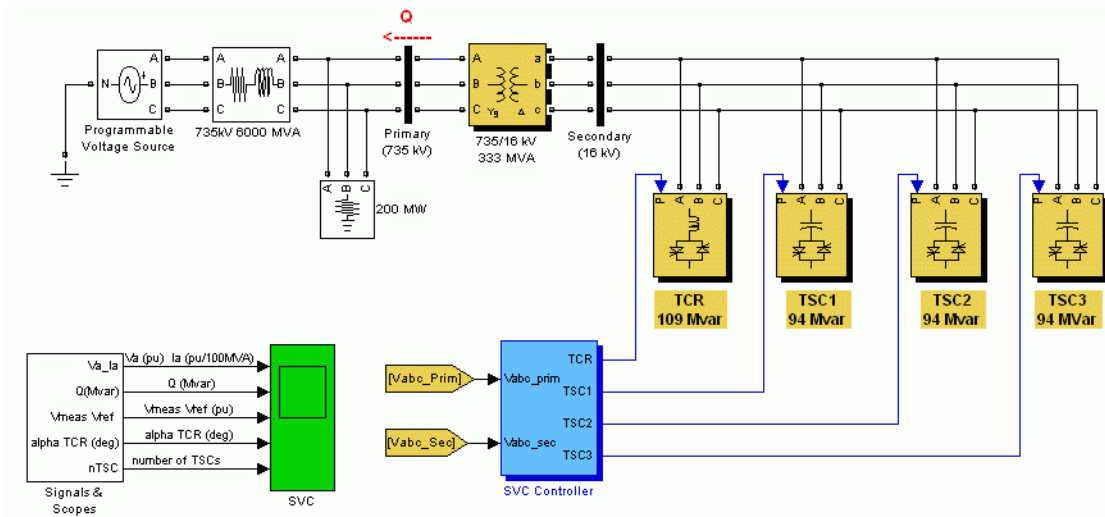

SPS Model of the 300 Mvar SVC on a 735 kV Power System (power_svc_1tcr3tscs)

SVC Power Components

The SVC consists of a 735 kV/16 kV, 333 MVA coupling transformer, one 109 Mvar TCR bank and three 94 Mvar TSC banks (TSC1 TSC2 TSC3) connected on the secondary side of the transformer.

Switching the TSCs in and out allows a discrete variation of the secondary reactive power from zero to 282 Mvar capacitive (at 16 kV) by steps of 94 Mvar, whereas phase control of the TCR allows a continuous variation from zero to 109 Mvar inductive. Taking into account the leakage reactance of the transformer (0.15 pu), the SVC equivalent susceptance seen from the primary side can be varied continuously from -1.04 pu/100 MVA (fully inductive) to +3.23 pu/100 Mvar (fully capacitive).

The SVC Controller monitors the primary voltage and sends appropriate pulses to the 24 thyristors (6 thyristors per three-phase bank) to obtain the susceptance required by the voltage regulator.

Use the **Diagram > Mask > Look Under Mask** menu item to see how the TCR and TSC subsystems are built. Each three-phase bank is connected in delta so that, during normal balanced operation, the zero-sequence triplen harmonics (3rd, 9th,...) remain trapped inside the delta, thus reducing harmonic injection into the power system.

The power system is represented by an inductive equivalent (6000 MVA short circuit level) and a 200-MW load. The internal voltage of the equivalent system can be varied by means of a Three-Phase Programmable Voltage Source block to observe the SVC dynamic response to changes in system voltage.

SVC Control System

Open the SVC Controller (see subsystem in SVC Control System).

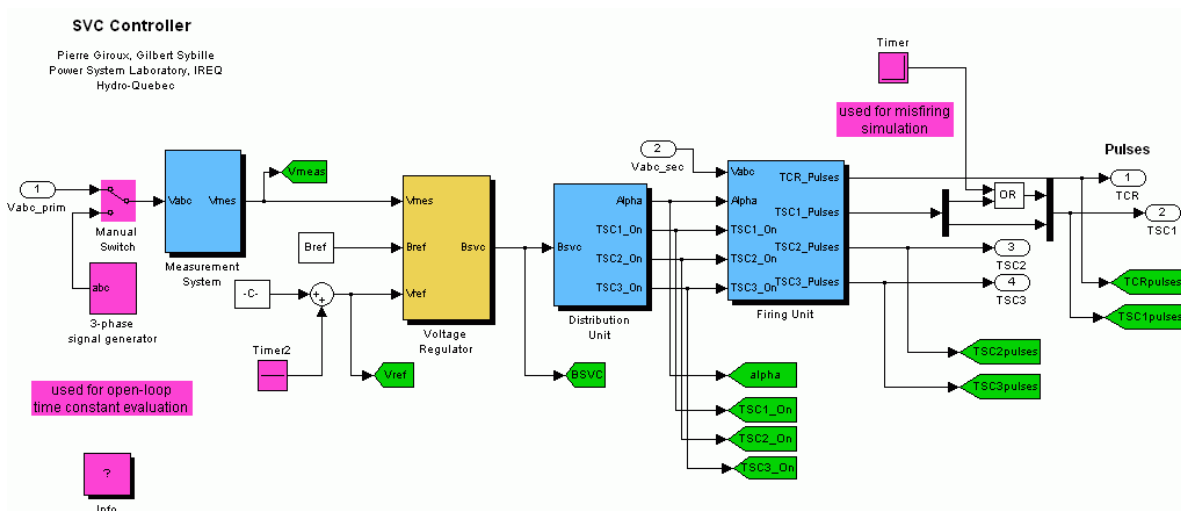

SVC Control System

The SVC control system consists of the following four main modules:

- Measurement System measures the positive-sequence primary voltage. This system uses discrete Fourier computation technique to evaluate fundamental voltage over a one-cycle running average window. The voltage measurement unit is driven by a phase-locked loop (PLL) to take into account variations of system frequency.
- Voltage Regulator uses a PI regulator to regulate primary voltage at the reference voltage (1.0 pu specified in the SVC Controller block menu). A voltage droop is incorporated in the voltage regulation to obtain a V-I characteristic with a slope (0.01 pu/100 MVA in this case). Therefore, when the SVC operating point changes from fully capacitive (+300 Mvar) to fully inductive (-100 Mvar) the SVC voltage varies between $1-0.03=0.97$ pu and $1+0.01=1.01$ pu.

- Distribution Unit uses the primary susceptance B_{svc} computed by the voltage regulator to determine the TCR firing angle α and the status (on/off) of the three TSC branches. The firing angle α as a function of the TCR susceptance B_{TCR} is implemented by a look-up table from the equation

$$B_{\text{TCR}} = \frac{2(\pi - \alpha) + \sin(2\alpha)}{\pi}$$

where B_{TCR} is the TCR susceptance in pu of rated TCR reactive power (109 Mvar)

- Firing Unit consists of three independent subsystems, one for each phase (AB, BC and CA). Each subsystem consists of a PLL synchronized on line-to-line secondary voltage and a pulse generator for each of the TCR and TSC branches. The pulse generator uses the firing angle α and the TSC status coming from the Distribution Unit to generate pulses. The firing of TSC branches can be synchronized (one pulse is sent at positive and negative thyristors at every cycle) or continuous. The synchronized firing mode is usually the preferred method because it reduces harmonics faster. Verify that the **Synchronized** firing mode has been selected in the **Firing Unit** dialog box.

Steady-State and Dynamic Performance of the SVC

Now observe the steady-state waveforms and the SVC dynamic response when the system voltage is varied. Open the **Programmable Voltage Source** menu and look at the sequence of voltage steps that are programmed. Also, open the **SVC Controller** block menu and check that the SVC is in Voltage regulation mode with a reference voltage of 1.0 pu. Run the simulation and observe waveforms on the SVC Scope block. These waveforms are reproduced below.

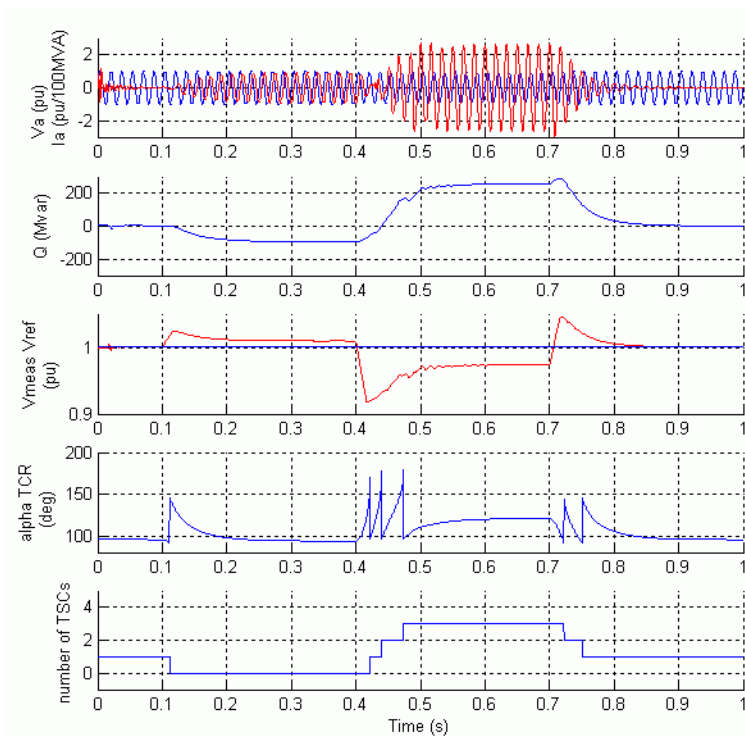

Waveforms Illustrating SVC Dynamic Response to System Voltage Steps

Initially the source voltage is set at 1.004 pu, resulting in a 1.0 pu voltage at SVC terminals when the SVC is out of service. As the reference voltage V_{ref} is set to 1.0 pu, the SVC is initially floating (zero current). This operating point is obtained with TSC1 in service and TCR almost at full conduction ($\alpha = 96$ degrees).

At $t=0.1$ s voltage is suddenly increased to 1.025 pu. The SVC reacts by absorbing reactive power ($Q=-95$ Mvar) to bring the voltage back to 1.01 pu. The 95% settling time is approximately 135 ms. At this point all TSCs are out of service and the TCR is almost at full conduction ($\alpha = 94$ degrees).

At $t=0.4$ s the source voltage is suddenly lowered to 0.93 pu. The SVC reacts by generating 256 Mvar of reactive power, thus increasing the voltage to 0.974 pu.

At this point the three TSCs are in service and the TCR absorbs approximately 40% of its nominal reactive power ($\alpha =120$ degrees).

Observe on the last trace of the scope how the TSCs are sequentially switched on and off. Each time a TSC is switched on the TCR α angle changes from 180 degrees (no conduction) to 90 degrees (full conduction). Finally, at $t=0.7$ s the voltage is increased to 1.0 pu and the SVC reactive power is reduced to zero.

You may open the Signal & Scopes subsystem to observe additional waveforms. The TCR voltage and current in branch AB as well as thyristors pulses are displayed on the TCR AB scope. The figure below zooms on three cycles when the firing angle α is 120 degrees.

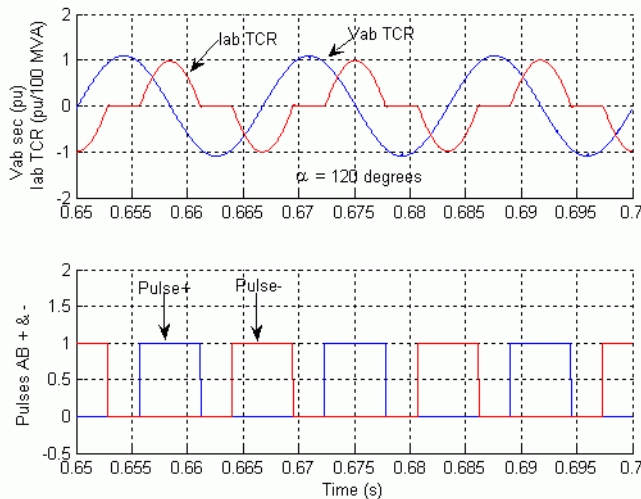

Steady-State Voltage and Current in TCR AB

Misfiring of TSC1

The final case study simulates a TSC misfiring.

Each time a TSC is switched off a voltage remains trapped across the TSC capacitors. If you look at the TSC1 Misfiring scope inside the Signals & Scope subsystem, you can observe the TSC1 voltage (first trace) and the TSC1 current (second trace) for branch AB. The voltage across the positive thyristor (thyristor conducting the positive current) is shown on the third trace and the pulses sent to this thyristor are shown on the fourth trace. Notice that the positive thyristor is fired at maximum negative TSC voltage, when the valve voltage is minimum.

If by mistake the firing pulse is not sent at the right time, very large overcurrents can be observed in the TSC valves. Look inside the SVC Controller block for how a misfiring can be simulated on TSC1. A Timer block and an OR block are used to add pulses to the normal pulses coming from the Firing Unit.

Open the Timer block menu and remove the 100 multiplication factor. The timer is now programmed to send a misfiring pulse lasting one sample time at time $t = 0.121$ s.

Restart simulation. Waveforms observed on the TSC1 Misfiring scope are reproduced below.

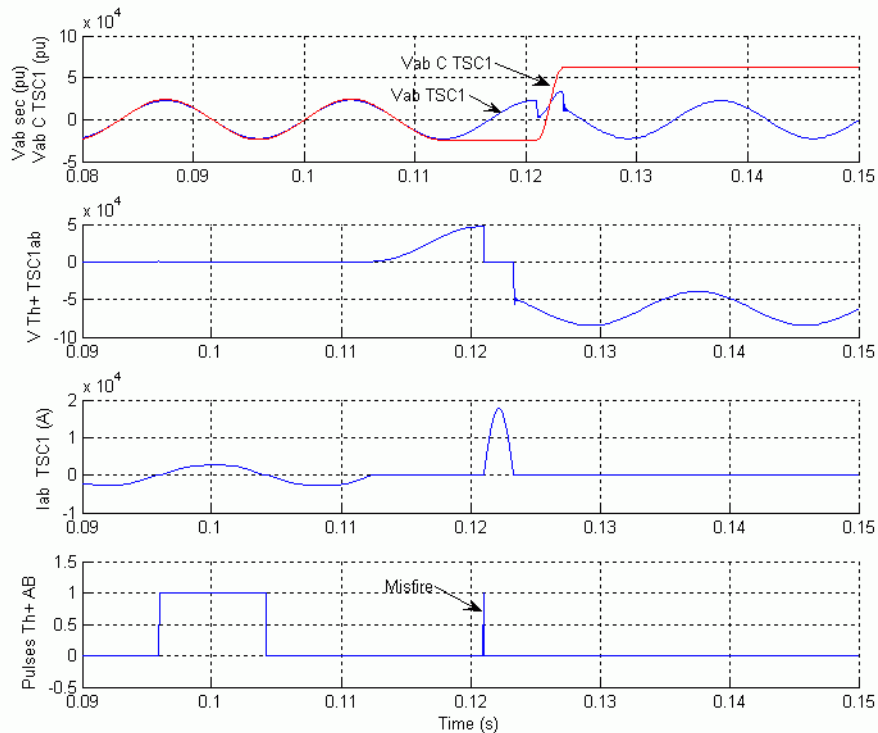

TSC Voltages and Current Resulting from Misfiring on TSC1

Observe that the misfiring pulse is sent when the valve voltage is maximum positive immediately after the TSC has blocked. This thyristor misfiring produces a large thyristor overcurrent (18 kA or 6.5 times the nominal peak current). Also, immediately

after the thyristor has blocked, the thyristor voltage reaches 85 kV (3.8 times the nominal peak voltage). To prevent such overcurrents and overvoltages, thyristor valves are normally protected by metal oxide arresters (not simulated here).

GTO-Based STATCOM

In this section...
“Introduction” on page 5-28
“Description of the STATCOM” on page 5-29
“Steady-State and Dynamic Performance of the STATCOM” on page 5-35

Introduction

The example described in this section illustrates application of SimPowerSystems software to study the steady-state and dynamic performance of a static synchronous compensator (STATCOM) on a transmission system. The STATCOM is a shunt device of the Flexible AC Transmission Systems (FACTS) family using power electronics. It regulates voltage by generating or absorbing reactive power. If you are not familiar with the STATCOM, please refer to the **Static Synchronous Compensator (Phasor Type)** block documentation, which describes the STATCOM principle of operation.

Depending on the power rating of the STATCOM, different technologies are used for the power converter. High power STATCOMs (several hundreds of Mvars) normally use GTO-based, square-wave voltage-sourced converters (VSC), while lower power STATCOMs (tens of Mvars) use IGBT-based (or IGCT-based) pulse-width modulation (PWM) VSC. The Static Synchronous Compensator (Phasor Type) block of the FACTS library is a simplified model, which can simulate different types of STATCOMs. You can use it with phasor simulation, available through the **Powergui** block, for studying dynamic performance and transient stability of power systems. Due to low frequencies of electromechanical oscillations in large power systems (typically 0.02 Hz to 2 Hz), this type of study usually requires simulation times of 30–40 seconds or more.

The STATCOM model described in this example is rather a detailed model with full representation of power electronics. It uses a square-wave, 48-pulse VSC and interconnection transformers for harmonic neutralization. This type of model requires discrete simulation at fixed time steps (25 μ s in this case) and it is used typically for studying the STATCOM performance on a much smaller time range (a few seconds). Typical applications include optimizing of the control system and impact of harmonics generated by converter.

Description of the STATCOM

The STATCOM described in this example is available in the `power_statcom_gto48p` model. Load this model and save it in your working directory as `case3` to allow further modifications to the original system. This model shown on SPS Model of the 100 Mvar STATCOM on a 500 kV Power System (`power_statcom_gto48p`) represents a three-bus 500 kV system with a 100 Mvar STATCOM regulating voltage at bus B1.

The internal voltage of the equivalent system connected at bus B1 can be varied by means of a Three-Phase Programmable Voltage Source block to observe the STATCOM dynamic response to changes in system voltage.

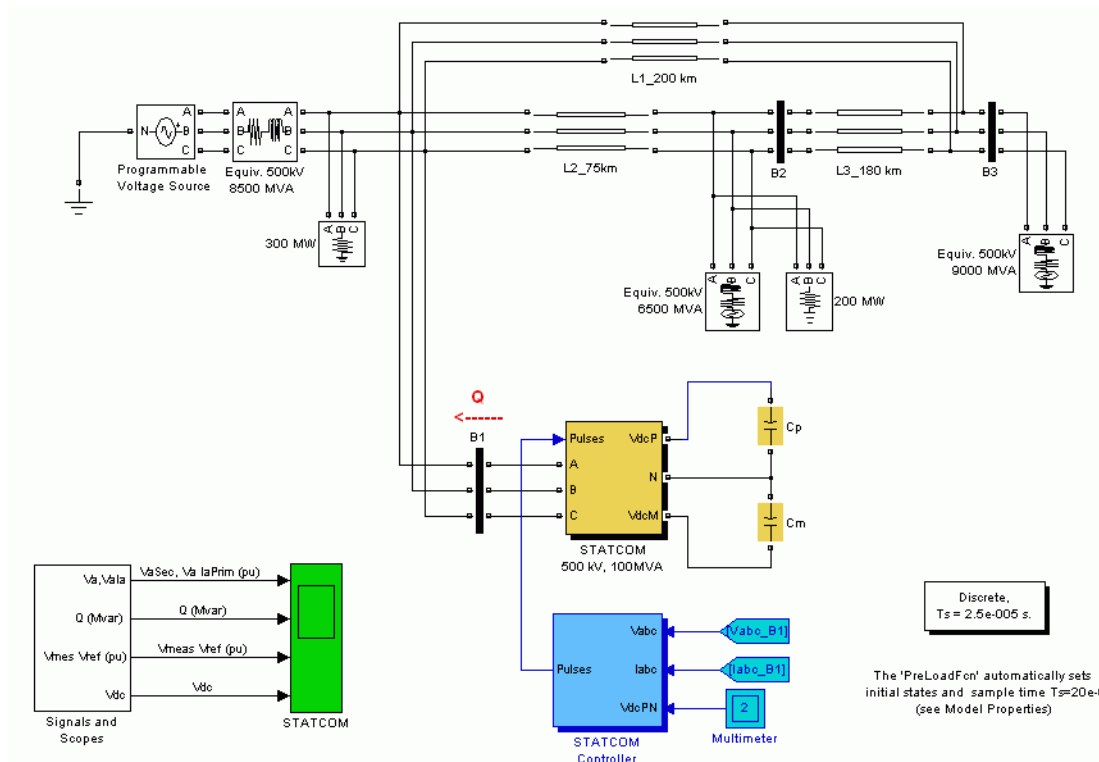

SPS Model of the 100 Mvar STATCOM on a 500 kV Power System (`power_statcom_gto48p`)

STATCOM Power Component

The STATCOM consists of a three-level 48-pulse inverter and two series-connected 3000 μF capacitors which act as a variable DC voltage source. The variable amplitude 60 Hz voltage produced by the inverter is synthesized from the variable DC voltage which varies around 19.3 kV.

Double-click on the STATCOM 500kV 100 MVA block (see subsystem in 48-Pulse Three-Level Inverter).

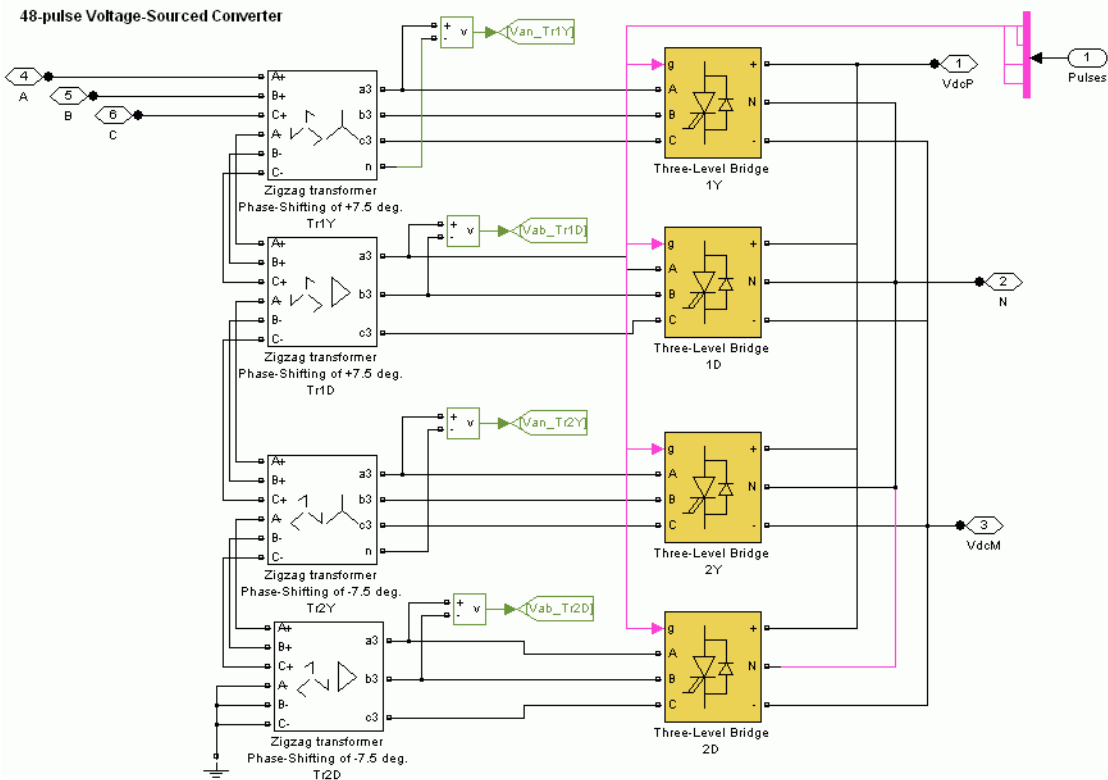

48-Pulse Three-Level Inverter

The STATCOM uses this circuit to generate the inverter voltage V2 voltage mentioned in the Static Synchronous Compensator (Phasor Type) block documentation. It

consists of four 3-phase 3-level inverters coupled with four phase shifting transformers introducing phase shift of ± 7.5 degrees.

Except for the 23rd and 25th harmonics, this transformer arrangement neutralizes all odd harmonics up to the 45th harmonic. Y and D transformer secondaries cancel harmonics $5+12n$ (5, 17, 29, 41,...) and $7+12n$ (7, 19, 31, 43,...). In addition, the 15° phase shift between the two groups of transformers (Tr1Y and Tr1D leading by 7.5° , Tr2Y and Tr2D lagging by 7.5°) allows cancellation of harmonics $11+24n$ (11, 35,...) and $13+24n$ (13, 37,...). Considering that all $3n$ harmonics are not transmitted by the transformers (delta and ungrounded Y), the first harmonics that are not canceled by the transformers are therefore the 23rd, 25th, 47th and 49th harmonics. By choosing the appropriate conduction angle for the three-level inverter ($\sigma = 172.5^\circ$), the 23rd and 25th harmonics can be minimized. The first significant harmonics generated by the inverter will then be 47th and 49th. Using a bipolar DC voltage, the STATCOM thus generates a 48-step voltage approximating a sine wave.

The following figure reproduces the primary voltage generated by the STATCOM 48-pulse inverter as well as its harmonics contents.

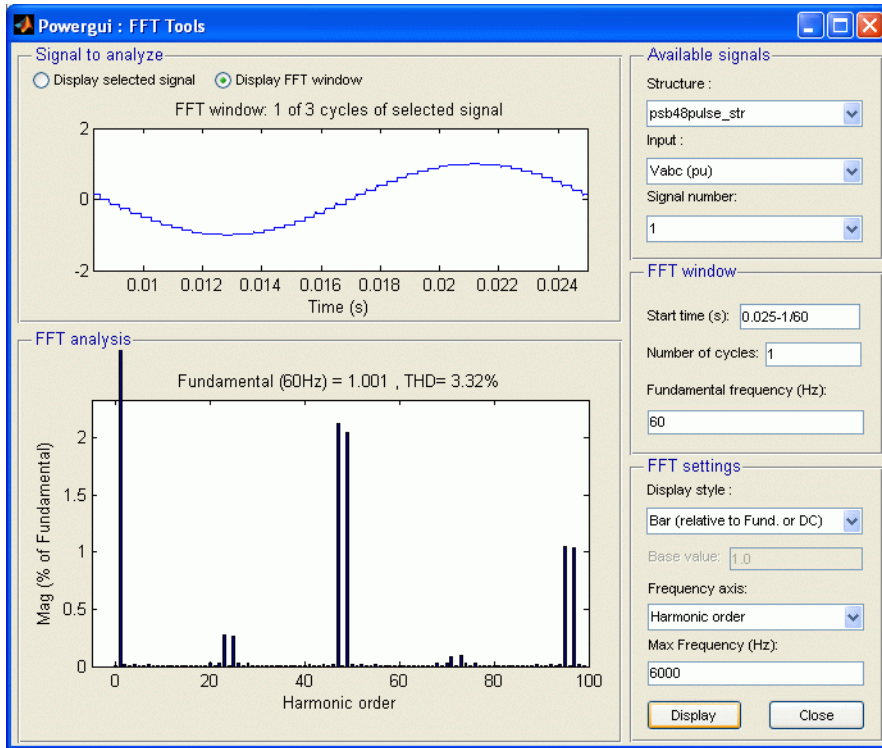

Frequency Spectrum of Voltage Generated by 48-Pulse Inverter at No Load

This frequency spectrum was obtained by running the `power_48pulsesegtoconverter` example, which uses the same converter topology. The FFT analysis was performed by using the **FFT Analysis** tool in the Powergui block. FFT uses one cycle of inverter voltage during the no-load operation and a 0–6000 Hz frequency range.

STATCOM Control System

Open the STATCOM Controller (see subsystem in STATCOM Control System).

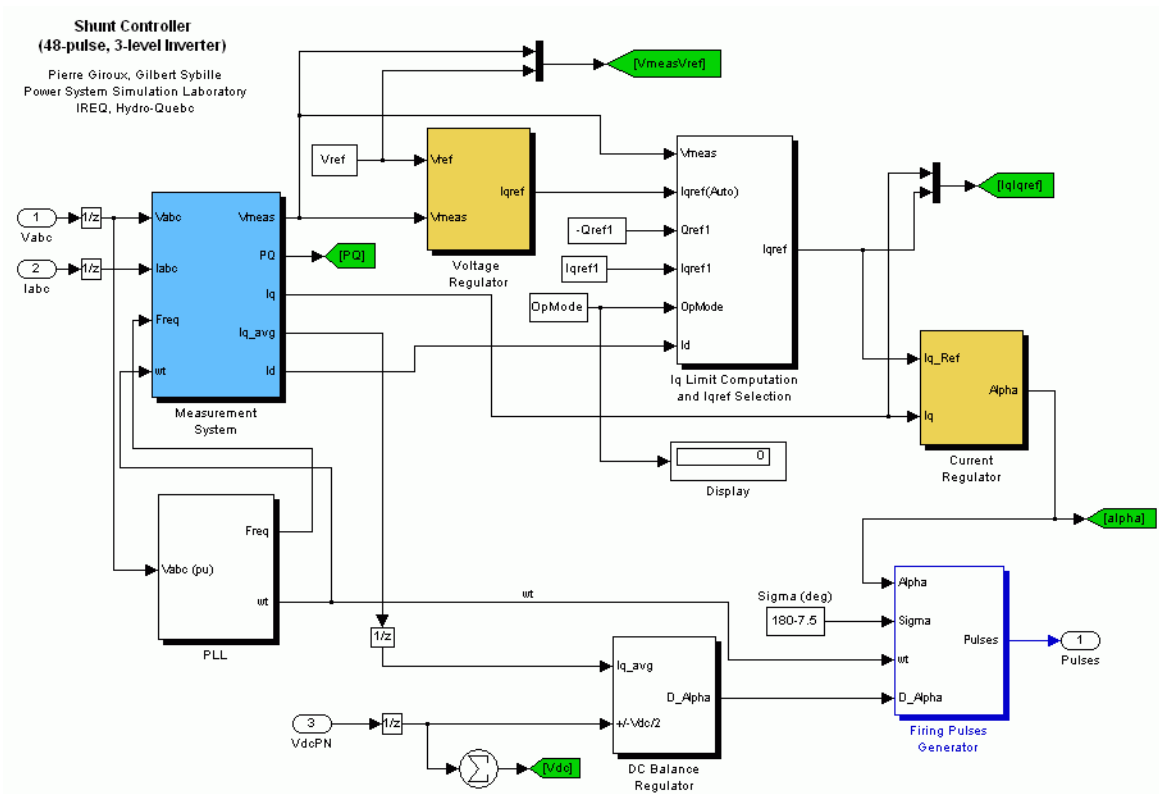

STATCOM Control System

The control system task is to increase or decrease the capacitor DC voltage, so that the generated AC voltage has the correct amplitude for the required reactive power. The control system must also keep the AC generated voltage in phase with the system voltage at the STATCOM connection bus to generate or absorb reactive power only (except for small active power required by transformer and inverter losses).

The control system uses the following modules:

- PLL (phase locked loop) synchronizes GTO pulses to the system voltage and provides a reference angle to the measurement system.

- Measurement System computes the positive-sequence components of the STATCOM voltage and current, using phase-to-dq transformation and a running-window averaging.
- Voltage regulation is performed by two PI regulators: from the measured voltage V_{meas} and the reference voltage V_{ref} , the Voltage Regulator block (outer loop) computes the reactive current reference I_{qref} used by the Current Regulator block (inner loop). The output of the current regulator is the α angle which is the phase shift of the inverter voltage with respect to the system voltage. This angle stays very close to zero except during short periods of time, as explained below.

A voltage droop is incorporated in the voltage regulation to obtain a V-I characteristics with a slope (0.03 pu/100 MVA in this case). Therefore, when the STATCOM operating point changes from fully capacitive (+100 Mvar) to fully inductive (-100 Mvar) the SVC voltage varies between $1-0.03=0.97$ pu and $1+0.03=1.03$ pu.

- Firing Pulses Generator generates pulses for the four inverters from the PLL output ($\omega.t$) and the current regulator output (α angle).

To explain the regulation principle, let us suppose that the system voltage V_{meas} becomes lower than the reference voltage V_{ref} . The voltage regulator will then ask for a higher reactive current output (positive I_q = capacitive current). To generate more capacitive reactive power, the current regulator will then increase α phase lag of inverter voltage with respect to system voltage, so that an active power will temporarily flow from AC system to capacitors, thus increasing DC voltage and consequently generating a higher AC voltage.

As explained in the preceding section, the conduction angle σ of the 3-level inverters has been fixed to 172.5° . This conduction angle minimizes 23rd and 25th harmonics of voltage generated by the square-wave inverters. Also, to reduce noncharacteristic harmonics, the positive and negative voltages of the DC bus are forced to stay equal by the DC Balance Regulator module. This is performed by applying a slight offset on the conduction angles σ for the positive and negative half-cycles.

The STATCOM control system also allows selection of Var control mode (see the STATCOM Controller dialog box). In such a case, the reference current I_{qref} is no longer generated by the voltage regulator. It is rather determined from the Q_{ref} or I_{qref} references specified in the dialog box.

Steady-State and Dynamic Performance of the STATCOM

You will now observe steady-state waveforms and the STATCOM dynamic response when the system voltage is varied. Open the programmable voltage source menu and look at the sequence of voltage steps that are programmed. Also, open the STATCOM Controller dialog box and verify that the STATCOM is in Voltage regulation mode with a reference voltage of 1.0 pu. Run the simulation and observe waveforms on the STATCOM scope block. These waveforms are reproduced below.

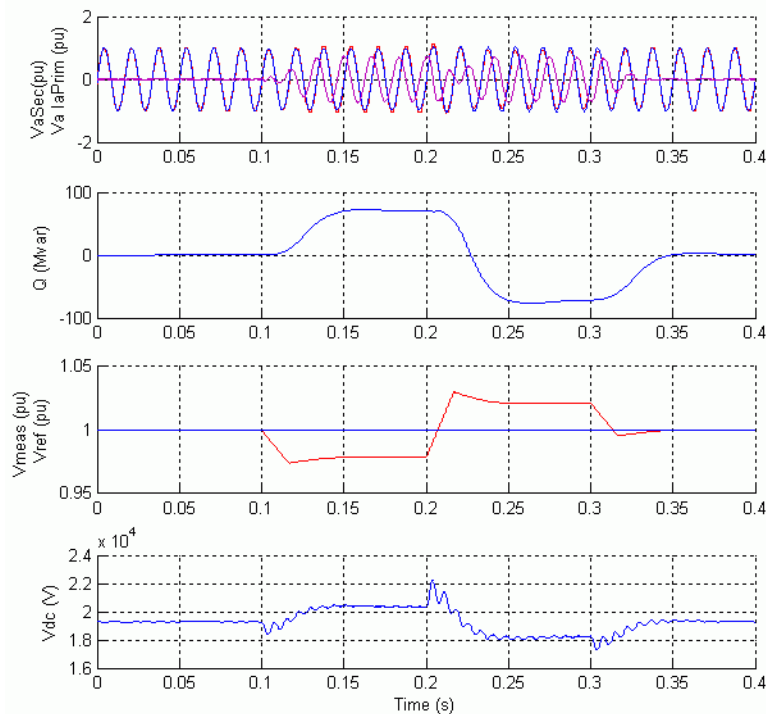

Waveforms Illustrating STATCOM Dynamic Response to System Voltage Steps

Initially the programmable voltage source is set at 1.0491 pu, resulting in a 1.0 pu voltage at bus B1 when the STATCOM is out of service. As the reference voltage V_{ref} is set to 1.0 pu, the STATCOM is initially floating (zero current). The DC voltage is 19.3 kV. At $t=0.1$ s, voltage is suddenly decreased by 4.5% (0.955 pu of nominal voltage). The

STATCOM reacts by generating reactive power ($Q=+70$ Mvar) to keep voltage at 0.979 pu. The 95% settling time is approximately 47 ms. At this point the DC voltage has increased to 20.4 kV.

Then, at $t=0.2$ s the source voltage is increased to 1.045 pu of its nominal value. The STATCOM reacts by changing its operating point from capacitive to inductive to keep voltage at 1.021 pu. At this point the STATCOM absorbs 72 Mvar and the DC voltage has been lowered to 18.2 kV. Observe on the first trace showing the STATCOM primary voltage and current that the current is changing from capacitive to inductive in approximately one cycle.

Finally, at $t=0.3$ s the source voltage is set back to its nominal value and the STATCOM operating point comes back to zero Mvar.

The figure below zooms on two cycles during steady-state operation when the STATCOM is capacitive and when it is inductive. Waveforms show primary and secondary voltage (phase A) as well as primary current flowing into the STATCOM.

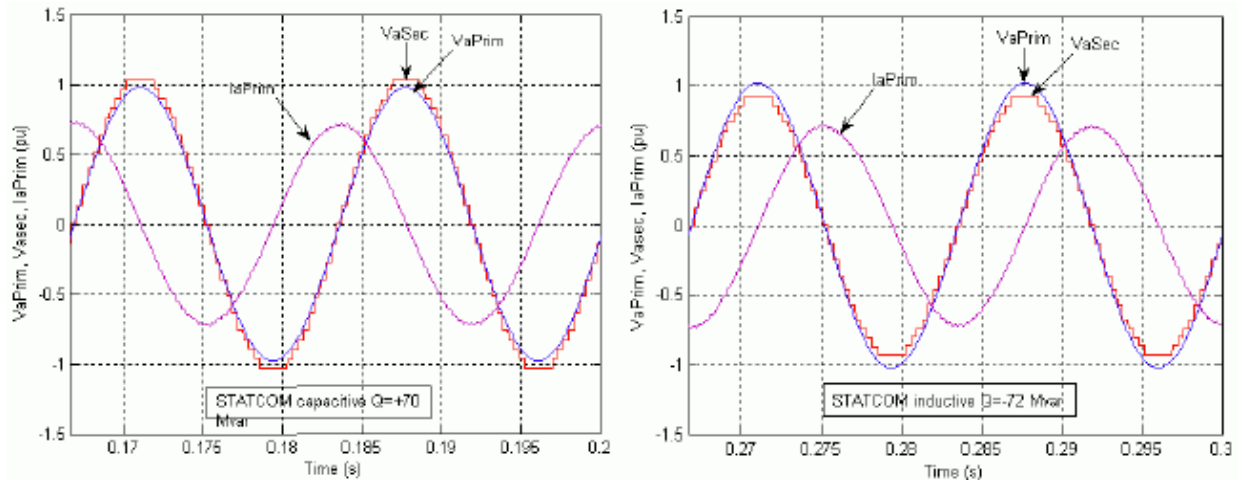

Steady-State Voltages and Current for Capacitive and Inductive Operation

Notice that when the STATCOM is operating in capacitive mode ($Q=+70$ Mvar), the 48-pulse secondary voltage (in pu) generated by inverters is higher than the primary voltage (in pu) and in phase with primary voltage. Current is leading voltage by 90°; the STATCOM is therefore generating reactive power.

On the contrary, when the STATCOM is operating in inductive mode, secondary voltage is lower than primary voltage. Current is lagging voltage by 90° ; the STATCOM is therefore absorbing reactive power.

Finally, if you look inside the Signals and Scopes subsystem you will have access to other control signals. Notice the transient changes on α angle when the DC voltage is increased or decreased to vary reactive power. The steady-state value of α (0.5 degrees) is the phase shift required to maintain a small active power flow compensating transformer and converter losses.

Thyristor-Based HVDC Link

In this section...

“Description of the HVDC Transmission System” on page 5-38

“Frequency Response of the AC and DC Systems” on page 5-39

“Control and Protection Systems” on page 5-40

“System Startup/Stop — Steady-State and Step Response” on page 5-44

“DC Line Fault” on page 5-51

“AC Line-to-Ground Fault at the Inverter” on page 5-53

Description of the HVDC Transmission System

The example in this section illustrates modeling of a high-voltage direct current (HVDC) transmission link using 12-pulse thyristor converters [1]. Perturbations are applied to examine the system performance. The objectives of this example are to demonstrate the use of SimPowerSystems blocks in combination with Simulink blocks in the simulation of a complete pole of a 12-pulse HVDC transmission system.

Open the `power_hvdc12pulse` model and save it under a different name to allow further modifications to the original system.

A 1000 MW (500 kV, 2 kA) DC interconnection is used to transmit power from a 500 kV, 5000 MVA, 60 Hz system to a 345 kV, 10000 MVA, 50 Hz system. The AC systems are represented by damped L-R equivalents with an angle of 80 degrees at fundamental frequency (60 Hz or 50 Hz) and at the third harmonic.

The rectifier and the inverter are 12-pulse converters using two Universal Bridge blocks connected in series. The converters are interconnected through a 300-km line and 0.5 H smoothing reactors. The converter transformers (Wye grounded/Wye/Delta) are modeled with Three-Phase Transformer (Three-Windings) blocks. The transformer tap changers are not simulated. The tap position is rather at a fixed position determined by a multiplication factor applied to the primary nominal voltage of the converter transformers (0.90 on the rectifier side; 0.96 on the inverter side).

From the AC point of view, an HVDC converter acts as a source of harmonic currents. From the DC point of view, it is a source of harmonic voltages.

The order n of these characteristic harmonics is related to the pulse number p of the converter configuration: $n = kp \pm 1$ for the AC current and $n = kp$ for the direct voltage, k being any integer. In the example, $p = 12$, so that injected harmonics on the AC side are 11, 13, 23, 25, and on the DC side are 12, 24.

AC filters are used to prevent the odd harmonic currents from spreading out on the AC system. The filters are grouped in two subsystems. These filters also appear as large capacitors at fundamental frequency, thus providing reactive power compensation for the rectifier consumption due to the firing angle α . For $\alpha = 30$ degrees, the converter reactive power demand is approximately 60% of the power transmitted at full load. The AC filters subsystem contains the high Q (100) tuned filters at the 11th and 13th harmonics and the low Q (3), or damped filter, used to eliminate the higher order harmonics, e.g., 24th and up. Extra reactive power is also provided by capacitor banks.

Two Breaker blocks apply faults on the rectifier DC side and on the inverter AC side to examine system performance.

The power system and the control and protection system are both discretized with the same sample time $T_s = 50 \mu\text{s}$. Some protection systems have a sample time of 1 or 2 ms.

Frequency Response of the AC and DC Systems

The section “Analyze a Simple Circuit” on page 1-12 explains how you can use the Impedance Measurement block to compute the impedance of a linear system from its state-space model. As the thyristor valves of the converters are nonlinear blocks, they are ignored in the impedance calculation and you get the impedances with the valves open.

The rectifier and inverter subsystems use Impedance Measurement blocks to measure the frequency response between phase A and phase B of the AC systems. Measuring the impedance between two phases gives two times the positive-sequence impedance. Therefore you specify a multiplication factor of 1/2 on the Impedance Measurement blocks to obtain the correct impedance value. The ZDC Impedance Measurement block measures the impedance on the DC line rectifier terminal side.

You can use the Impedance vs Frequency Measurement tool of Powergui to display the magnitude and phase as a function of frequency measured by the three Impedance Measurement blocks..

The magnitudes of the three impedances as a function of frequency are shown here.

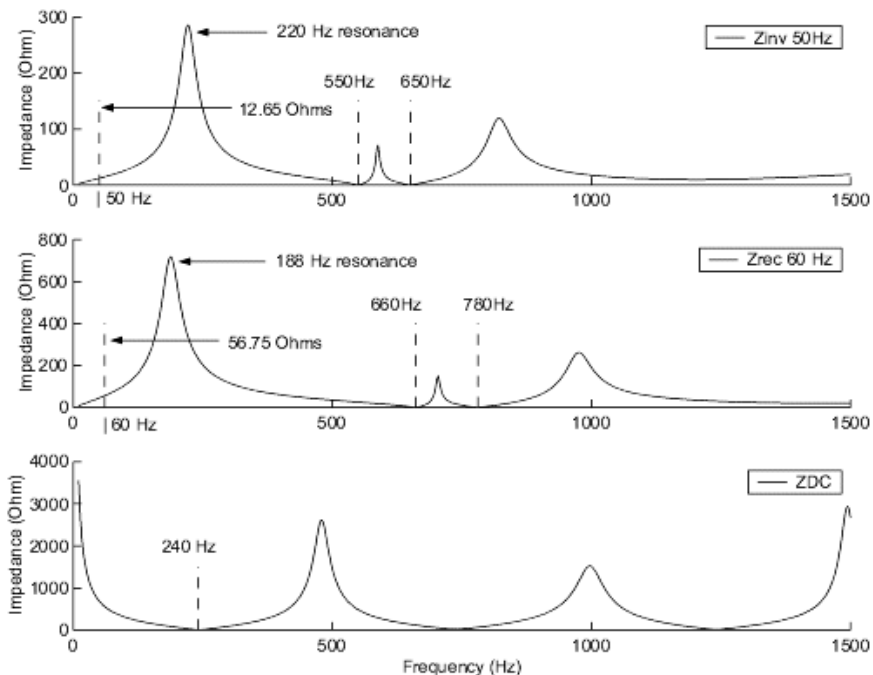

Positive-Sequence Impedances of the Two AC Systems and of the DC Line

Note the two minimum impedances on the Z magnitudes of the AC systems. These series resonances are created by the 11th and 13th harmonic filters. They occur at 660 Hz and 780 Hz on the 60 Hz system. Note also that the addition of 600 Mvar capacitive filters on the inductive systems creates resonances around 188 Hz on the rectifier side and 220 Hz on the inverter side. In the 60 Hz region, the magnitude is 56.75 Ω for the 60 Hz system, corresponding to an effective short-circuit level of $500^2/56.75 = 4405$ MVA on the rectifier side (5000 MVA - 600 Mvar of filters).

For the DC line, note the series resonance at 240 Hz, which corresponds to the main mode likely to be excited on the DC side, under large disturbances.

Control and Protection Systems

The Rectifier Pole Control (Current) and the Inverter Pole Control (Current/Voltage/ Γ) subsystems generate the current reference for both converters and initiates

the starting and stopping of the DC power transmission. At the inverter, the Gamma Measurement subsystem measures the extinction angle Γ of the 6-pulse thyristor converters.

The protection systems can be switched on and off. At the rectifier, the DC fault protection detects a fault on the line and takes the necessary action to clear the fault. The Low AC Voltage Detection subsystem at the rectifier and inverter serves to discriminate between an AC fault and a DC fault. At the inverter, the Commutation Failure Prevention Control subsystem [2] mitigates commutation failures due to AC voltage dips.

Synchronization and Firing System

The synchronization and generation of the 12 firing pulses is performed by the 12-Pulse Firing Control system. This system uses the primary voltages to synchronize and generate the pulses according to the alpha firing angle computed by converter controller. The synchronizing voltages are measured at the primary side of the converter transformer because the waveforms are less distorted. A Phase Locked Loop (PLL) is used to generate three voltages synchronized on the fundamental component of the positive-sequence voltages. The firing pulse generator is synchronized to the three voltages generated by the PLL. At the zero crossings of the commutating voltages (AB, BC, CA), a ramp is reset. A firing pulse is generated whenever the ramp value becomes equal to the desired delay angle provided by the controller.

Steady-State V-I Characteristic

The Rectifier Pole Control and the Inverter Pole Control subsystems implement this steady-state characteristic:

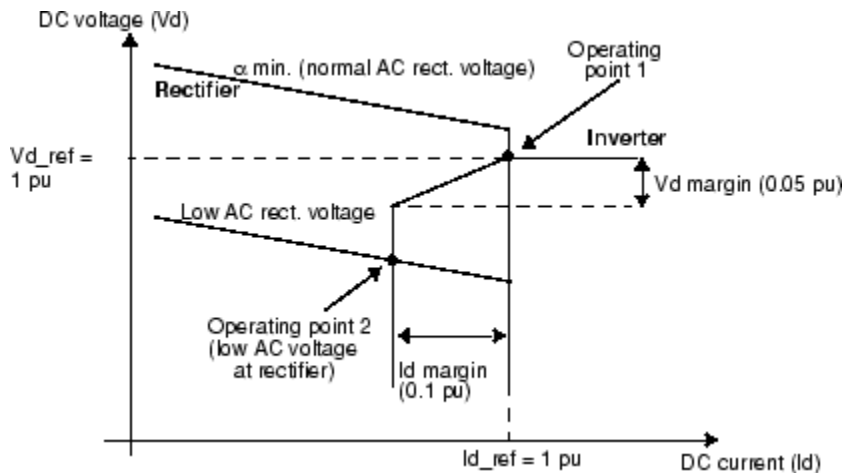

Rectifier and Inverter Steady-State Characteristics and VDCOL Function

In normal operation, the rectifier controls the current at the I_{d_ref} reference value, whereas the inverter controls the voltage or gamma at the V_{d_ref} or Γ_{min} reference value.

The system normally operates at point 1 as shown in the figure. However, during a severe contingency producing a voltage drop on the AC system 1 feeding the rectifier, the operating point moves to point 2. The rectifier, therefore, is forced to a minimum α mode and the inverter is in current control mode. Similarly, a voltage drop on the AC system feeding the inverter will force a control mode change to Gamma regulation to limit the angle to γ_{min} . During severe contingency, a faster response is necessary to increase the commutation margin and consequently to reduce the probability of a commutation failure. The Commutation Failure Prevention Control subsystem (look under the Inverter protections block) generates a signal that decreases the maximum limit of the delay angle during the voltage drop (e.g., during an AC fault).

Note $\gamma = \text{extinction angle} = 180^\circ - \alpha - \mu$, $\mu = \text{commutation or overlap angle}$

VDCOL Function

Another important control function is implemented to change the reference current according to the value of the DC voltage. This control, named Voltage Dependent Current

Order Limiter (VDCOL), automatically reduces the reference current (I_{d_ref}) set point when V_{dL} decreases (as, for example, during a DC line fault or a severe AC fault). Reducing the I_d reference currents also reduces the reactive power demand on the AC system, helping to recover from fault. The VDCOL parameters are explained by this diagram:

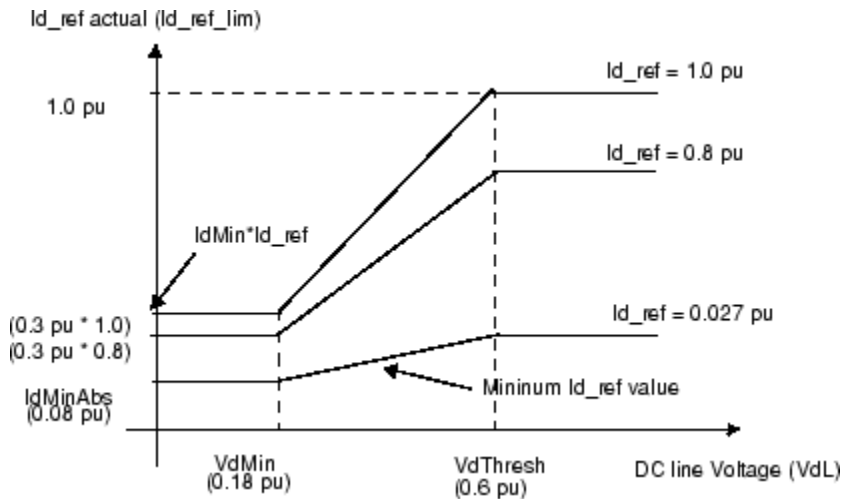

VDCOL Characteristic; $I_{d_ref} = f(V_{dL})$

The I_{d_ref} value starts to decrease when the V_d line voltage falls below a threshold value $V_{dThresh}$. The actual reference current used by the controllers is available at the second controller output, named $I_{d_ref_lim}$. $I_{dMinAbs}$ is the absolute minimum I_{d_ref} value. When the DC line voltage falls below the $V_{dThresh}$ value, the VDCOL drops instantaneously to I_{d_ref} . However, when the DC voltage recovers, VDCOL limits the I_{d_ref} rise time with a time constant defined by parameter T_{up} .

Current, Voltage, and Gamma Regulators

Both rectifier and inverter controls have current regulator calculating firing α_i . At the inverter, operating in parallel with the current regulator are the voltage and/or gamma regulators calculating firing angles α_v and/or α_g . The effective α angle is the minimum value of α_i , α_v and/or α_g . All regulators are of the proportional- integral type. They should have high enough gains for low frequencies (<10 Hz) to maintain the current, voltage, or gamma response equal to the reference current ($I_{d_ref_lim}$), reference voltage

(V_d_ref), or reference gamma (Γ_{min}), as long as α is within the minimum and maximum limits ($5^\circ < \alpha < 166^\circ$ for rectifier, $92^\circ < \alpha < 166^\circ$ for inverter). As described before, a signal (D_alpha) received from the Commutation Failure Prevention protection can temporarily reduce the 166° limit at the inverter. The regulator gains K_p and K_i are adjusted during small perturbations in the reference.

Another particularity of the regulator is the linearization of the proportional gain. As the V_d voltage generated by the rectifier and the inverter is proportional to $\cos(\alpha)$, the ΔV_d variation due to a $\Delta\alpha$ change is proportional to $\sin(\alpha)$. With a constant K_p value, the effective gain is, therefore, proportional to $\sin(\alpha)$. To keep a constant proportional gain, independent of the α value, the gain is linearized by multiplying the K_p constant by $1/\sin(\alpha)$. This linearization is applied for a range of α defined by two limits specified in the Rectifier and Inverter Pole Control blocks.

System Startup/Stop — Steady-State and Step Response

The system is programmed to start and reach a steady state. Then a step is applied first to the reference current and later to the voltage reference so you can observe the dynamic response of the regulators. Finally, a stop sequence is initiated to bring the power transmission smoothly down before blocking the converters. Notice in the Converter Controller that after reception of the Stop signal a $Forced_alpha$ is ordered for 0.150 s, and then 0.1 s later the blocking of the pulses is ordered.

Start the simulation and observe the signals on the Rectifier and Inverter scopes. The waveforms are reproduced here:

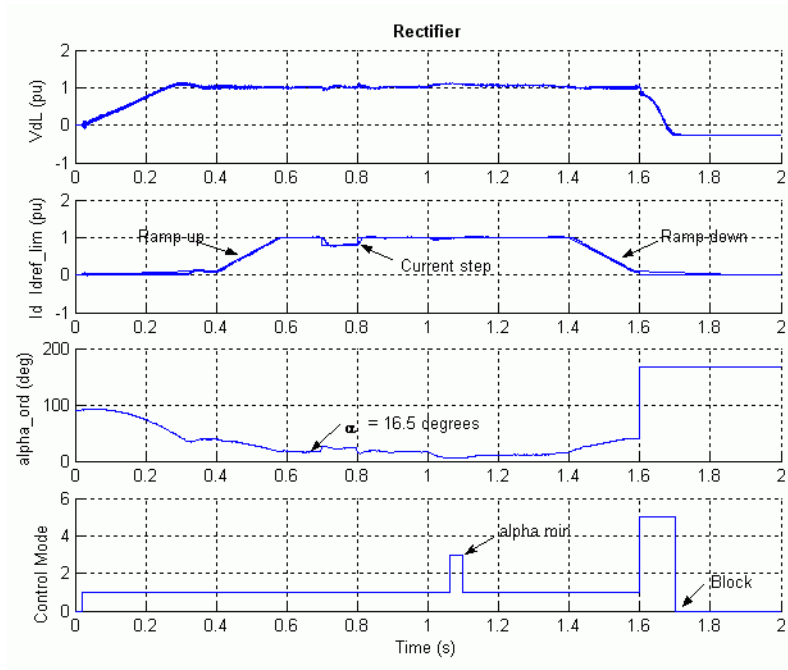

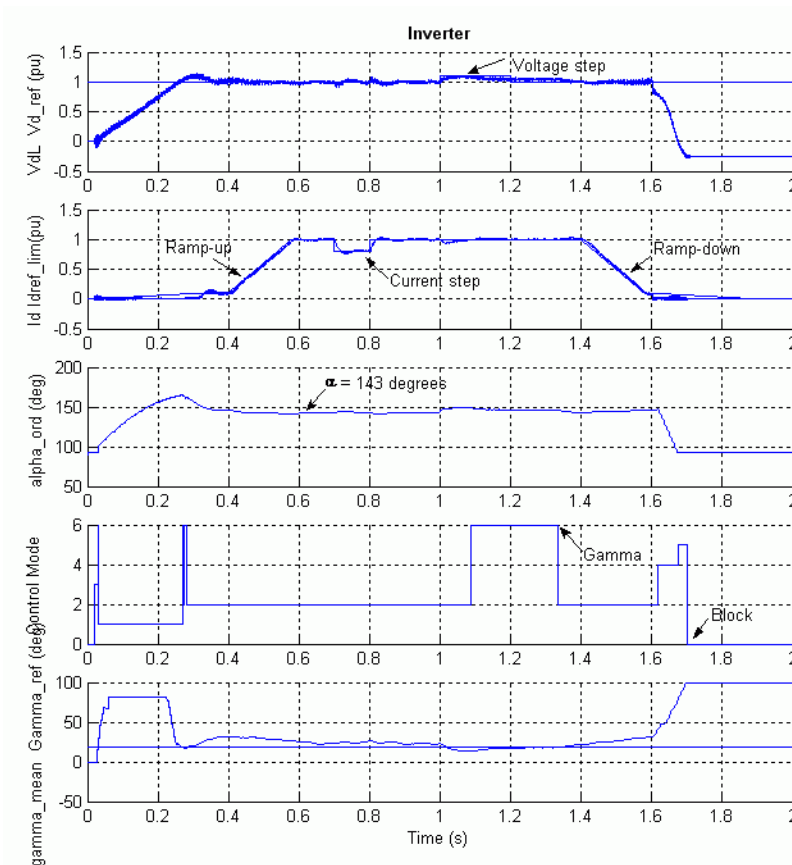

Startup/Stop of the DC System and Step Applied on the Current and Voltage Reference

In the Master Control, the converters pulse generators are deblocked and the power transmission started by ramping the reference current at $t = 20$ ms. The reference reaches the minimum value of 0.1 pu in 0.3 s. Observe that the DC current starts to build and the DC line is charged at its nominal voltage. At $t = 0.4$ s, the reference current is ramped from 0.1 to 1 pu (2 kA) in 0.18 s (5 pu/s). The DC current reaches steady state at the end of the starting sequence at approximately 0.58 s. The rectifier controls the current and the inverter controls the voltage. Trace 1 of both Rectifier and Inverter scopes shows the DC line voltage (1 pu = 500 kV). At the inverter, the voltage reference is also shown. Trace 2 shows the reference current and the measured I_d current (1 pu = 2 kA). During the ramp, the inverter is actually controlling the current (Trace

4: Mode = 1) to the value of $I_{d_ref_lim}$ less the Current Margin (0.1 pu) and the rectifier tries to control the current at $I_{d_ref_lim}$. At the inverter, the control mode changes from current control to gamma control (Mode = 6) before stabilizing to voltage control (Mode = 2) at $t = 0.3$ s. The rectifier becomes thereafter in control of the current. However, a control mode change will occur and alpha is limited to the minimum value of 5 degrees (Mode = 3) during an increase of the DC voltage initiated by a voltage reference increase at the inverter, as explained in the next paragraph. At steady state (measured at t between 1.3 and 1.4 s), the α firing angles are around 16.5 degrees and 143 degrees respectively on the rectifier and inverter side. The inverter control measures the extinction angle γ for each thyristor of the two six-pulse bridges (i.e., the bridge connected to the Wye and Delta windings) by determining the elapsed time expressed in electrical degrees from the end of current conduction to the zero crossing of the commutating voltage. The mean value of the measured gamma for the last 12 extinctions (6 of the Delta converter and 6 of the Wye converter) is shown in traces 5 along with Gamma reference. In steady state, the mean γ is around 22.5 degrees.

At $t = 0.7$ s, a -0.2 pu step is applied during 0.1 s to the reference current so that you can observe the dynamic response of the regulators. Later on, at $t = 1.0$ s, a 0.1 pu step is applied during 0.2 s at the inverter reference voltage. Observe that at the inverter the extinction angle reaches the reference value (e.g., the minimum acceptable value) and that the Gamma regulator takes control at t around 1.1 s. At t around 1.3 s the voltage regulator retakes control of the voltage.

At $t = 1.4$ s the Stop sequence is initiated by ramping down the current to 0.1 pu. At $t = 1.6$ s a Forced-alpha (to 166 deg) at the rectifier extinguishes the current and at the inverter the Forced-alpha (to 92 deg with a limited rate) brings down the DC voltage due to the trapped charge in the line capacitance. At $t = 1.7$ s the pulses are blocked in both converters.

Comparison of Theory and Simulation Results in Steady State

The main equations governing the steady-state operation of the DC system are given here so that you can compare the theoretical values to the simulation results.

The following expression relates the mean direct voltage V_d of a 12-pulse bridge to the direct current I_d and firing angle α (neglecting the ohmic losses in the transformer and thyristors):

$$V_d = 2 \times (V_{do} \times \cos(\alpha) - R_c \times I_d)$$

where V_{do} is the ideal no-load direct voltage for a six-pulse bridge:

$$V_{do} = (3\sqrt{2} / \pi) \times V_c$$

V_c is the line-to-line RMS commutating voltage that is dependent on the AC system voltage and the transformer ratio.

R_c is the equivalent commutating resistance.

$$R_c = (3 / \pi) \times X_c$$

X_c is the commutating reactance or transformer reactance referred to the valve side.

The following rectifier parameters were used in the simulation.

The V_c voltage must take into account the effective value of the voltage on the 500 kV bus and the transformer ratio. If you look at the waveforms displayed on the AC_Rectifier scope, you find 0.96 pu when the direct current I_d has reached its steady state (1 pu).

If you open the rectifier transformer dialog box, you find a multiplication factor of 0.90 applied to the primary nominal voltage. The voltage applied to the inverter is therefore boosted by a factor of 1/0.90.

$$V_c = 0.96 * 200 \text{ kV} / 0.90 = 213.3 \text{ kV}$$

$$I_d = 2 \text{ kA}$$

$$\alpha = 16.5^\circ$$

$$X_c = 0.24 \text{ pu, based on 1200 MVA and } 222.2 \text{ kV} = 9.874 \Omega$$

Therefore, this theoretical voltage corresponds well with the expected rectifier voltage calculated from the inverter voltage and the voltage drop in the DC line ($R = 4.5 \Omega$) and in the rectifier smoothing reactor ($R = 1 \Omega$):

$$V_d = V_d L_{inverter} + (R_{DCline} + R_{inductance}) \times I_d$$

$$V_d = 500 \text{ kV} + (4.5 \Omega + 1 \Omega) \times 2 = 511 \text{ kV}$$

The μ commutation or overlap angle can also be calculated. Its theoretical value depends on α , the DC current I_d , and the commutation reactance X_c .

$$V_{do} = (3\sqrt{2} / \pi) \times 213.3 = 288.1 \text{ kV}$$

$$R_c = (3 / \pi) \times 9.874 = 9.429 \Omega$$

$$V_d = 2 \times (288.1 \text{ kV} \times \cos(16.5^\circ) - 9.429 \times 2) = 515 \text{ kV}$$

$$\mu = \arccos \left[\cos(\alpha) - \frac{X_c \cdot I_d \cdot \sqrt{2}}{V_c} \right] - \alpha$$

$$\mu = \arccos \left[\cos(16.5^\circ) - \frac{9.874 \cdot 2 \cdot \sqrt{2}}{213.3} \right] - 16.5^\circ = 17.6^\circ$$

Now verify the commutation angle by observing the currents in two valves, for example, current extinction in valve 1 and current buildup in valve 3 of the Y six-pulse bridge of the rectifier. These signals are available in the VALVE13_RECT scope.

The waveforms illustrating two cycles are shown in the following figure. The measured commutation angle is 14 steps of $50 \mu\text{s}$ or 15.1° of a 60 Hz period. The resolution with a $50 \mu\text{s}$ time step is 1.1° ; this angle compares reasonably well with the theoretical value.

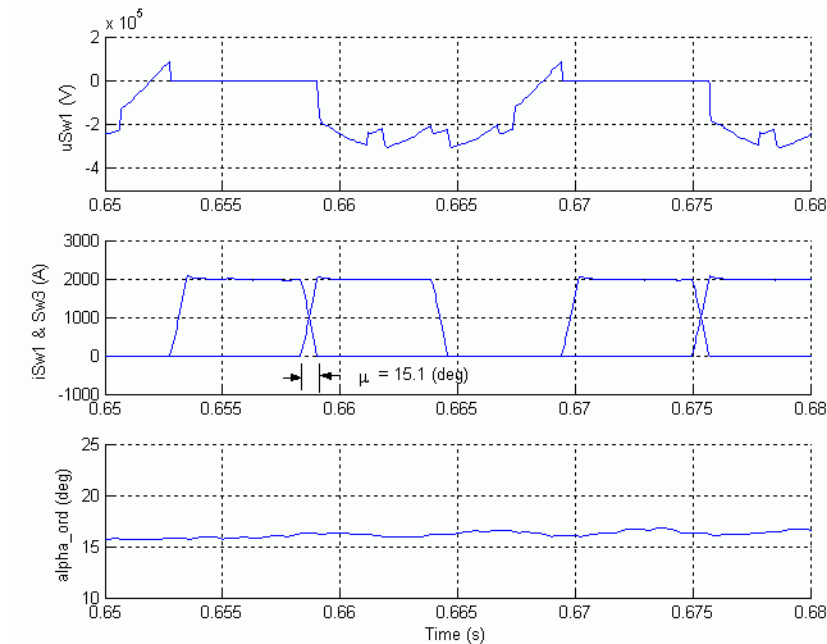

Valve Voltage and Currents (Commutation from Valve 1 to Valve3)

Finally, to validate the γ measurement at the inverter, observe the valve 1 voltage and current in the VALVE1_INV scope. Also observe the commutating voltage corresponding to the outgoing valve 1 to be extinguished and the mean value of γ as shown in Current and Commutation Voltage of Valve 1 Showing γ . Verify also that the values of α , μ , and γ add up to 180° .

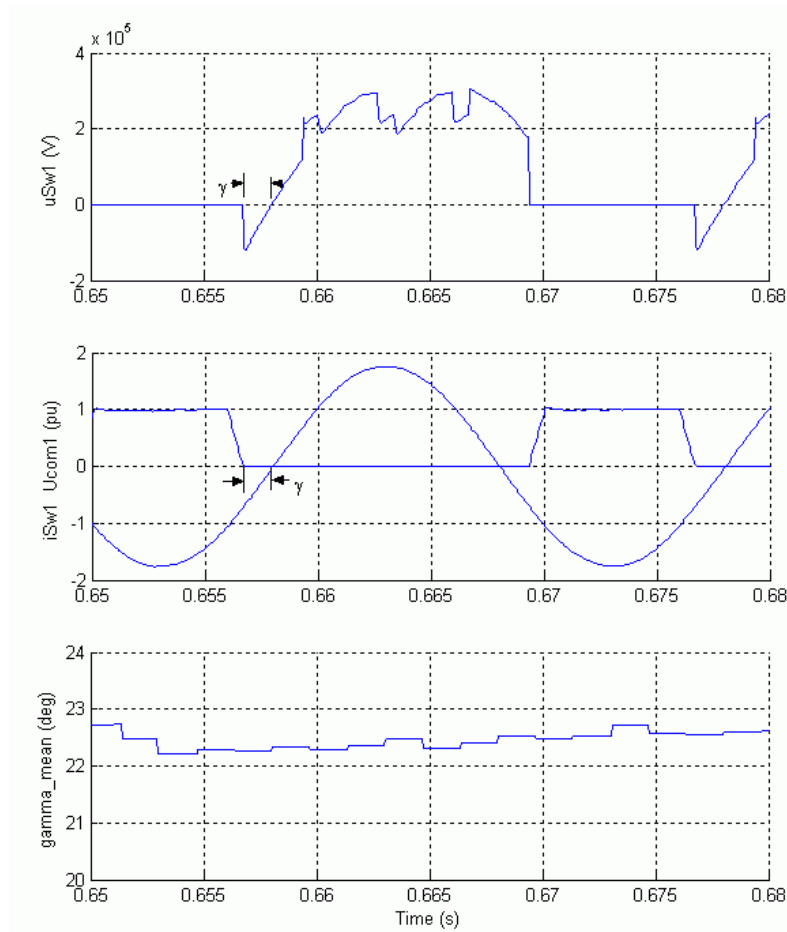

Current and Commutation Voltage of Valve 1 Showing γ

DC Line Fault

Deactivate the steps applied on the current reference and on the voltage reference in the Master Control and in the Inverter Control and Protection respectively by setting the switches in lower position. In the DC Fault block, change the multiplication factor of 100 to 1, so that a fault is now applied at $t = 0.7$ s. Reduce the Simulation Stop time to 1.4 s. Open the Rectifier scope as well as the Fault scope to observe the fault current and the Protection Rectifier scope to observe the DC Fault protection action. Restart the simulation.

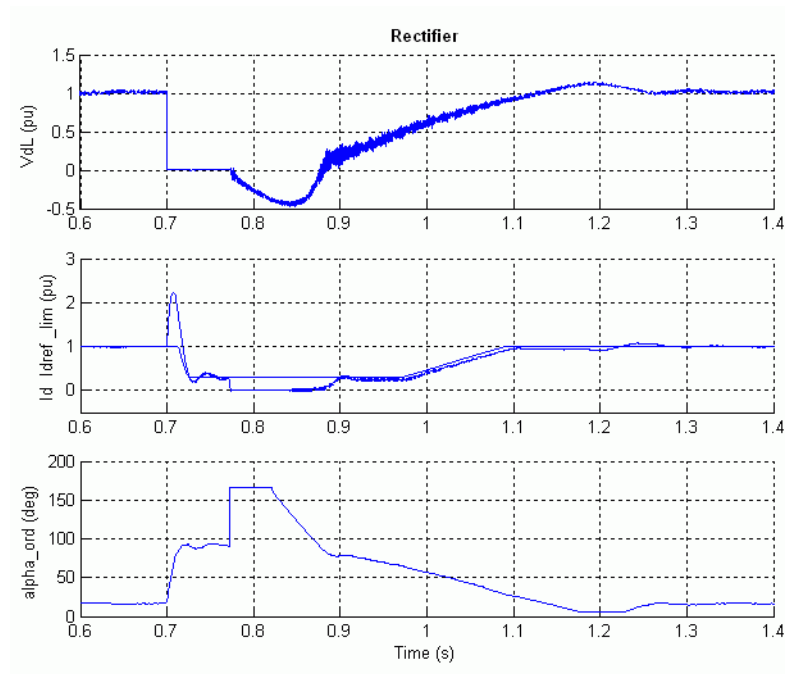

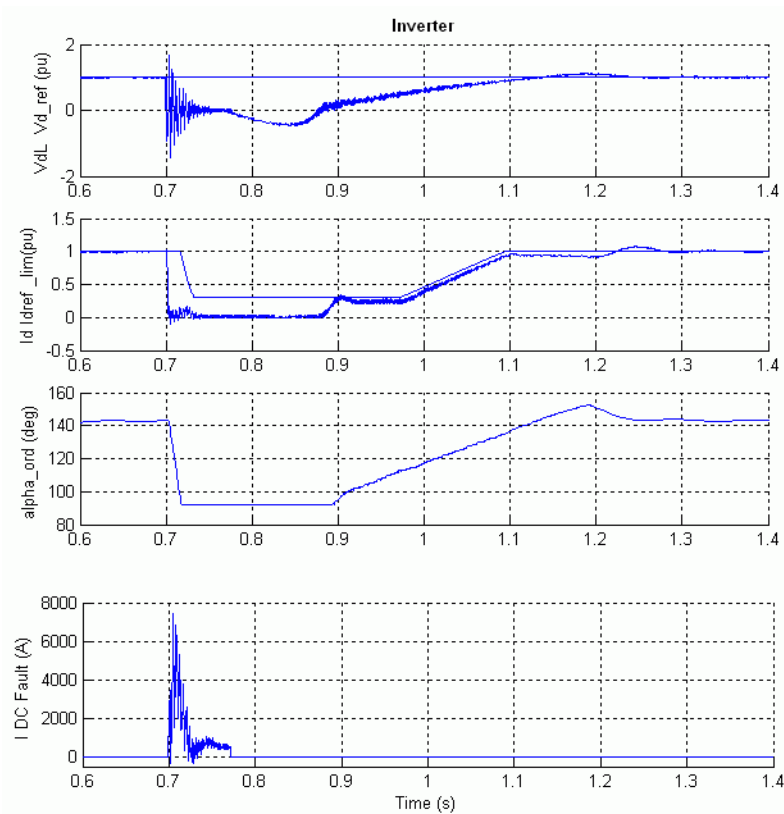

DC Line Fault on the Rectifier Side

At fault application ($t = 0.7$ s), the DC current increases to 2.2 pu and the DC voltage falls to zero at the rectifier. This DC voltage drop is seen by the Voltage Dependent Current Order Limiter (VDCOL) and the DC Fault protection. The VDCOL reduces the reference current to 0.3 pu at the rectifier. A DC current still continues to circulate in the fault. Then, at $t = 0.77$ s, the rectifier α firing angle is forced to 166 degrees by the DC Fault protection after detecting a low DC voltage. The rectifier now operates in inverter mode. The DC line voltage becomes negative and the energy stored in the line is returned to the AC system, causing rapid extinction of the fault current at its next zero crossing. Then α is released at $t = 0.82$ s and the normal DC voltage and current recover in approximately 0.5 s. Notice, the temporary mode change in the Rectifier controls between 1.18 s and 1.25 s.

AC Line-to-Ground Fault at the Inverter

Now modify the fault timings to apply a line-to-ground fault. In the DC Fault block, change the multiplication factor of 1 to 100, so that the DC fault is now eliminated. In the A-G Fault block, change the multiplication factor in the switching times to 1, so that a six-cycle line-to-ground fault is now applied at $t = 0.7$ s at the inverter. Restart the simulation.

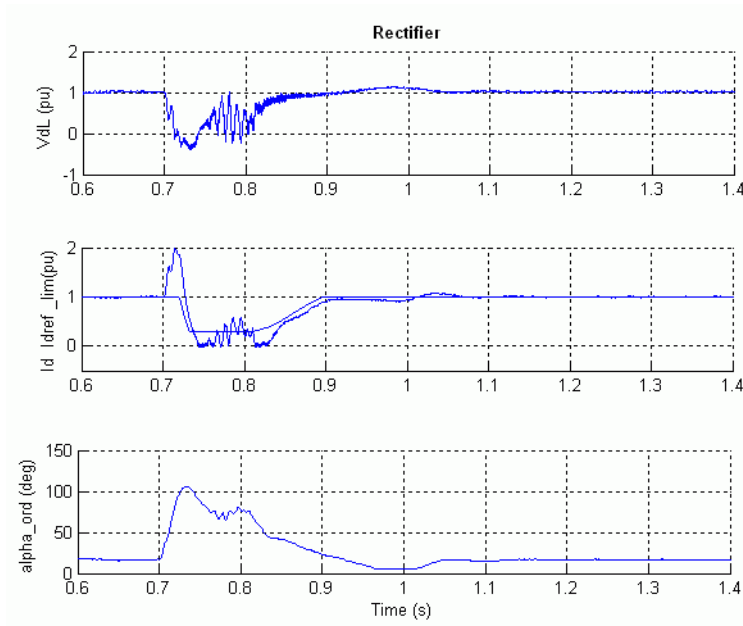

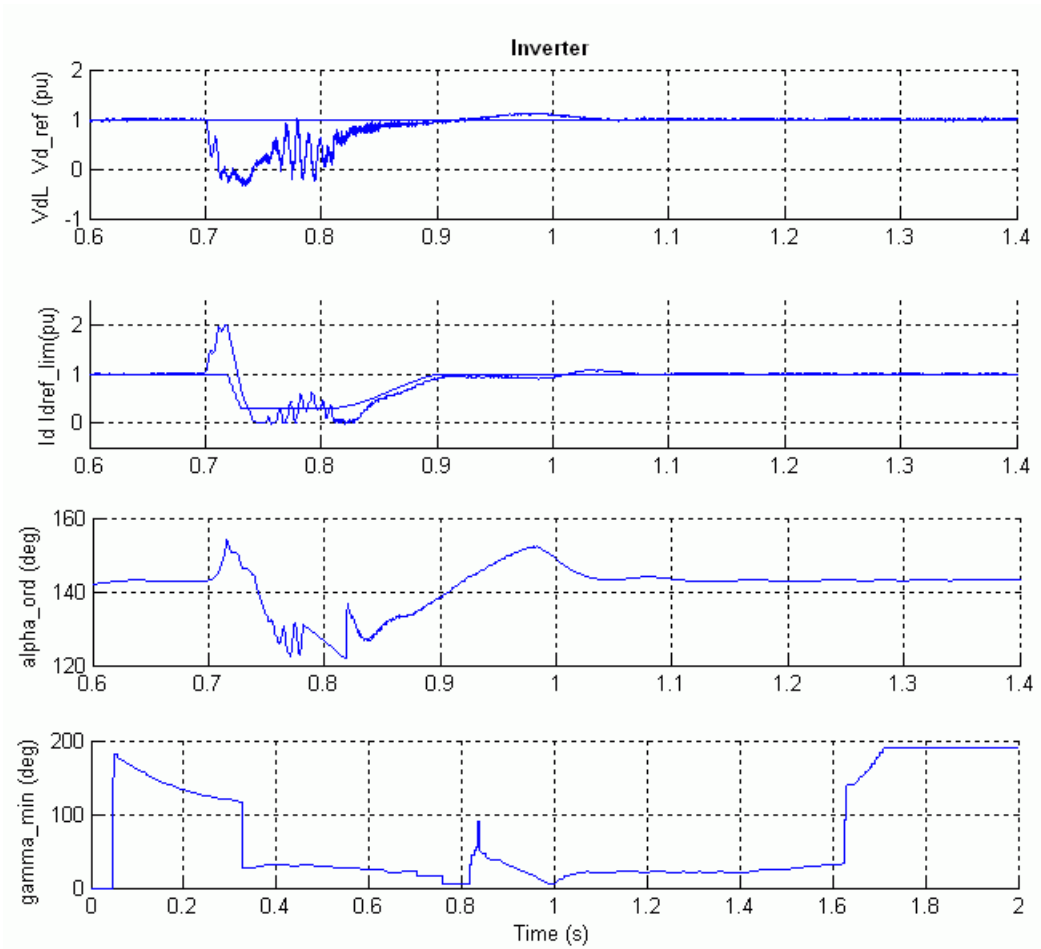

Rectifier, Inverter Signals for an AC Line Fault on Inverter Side

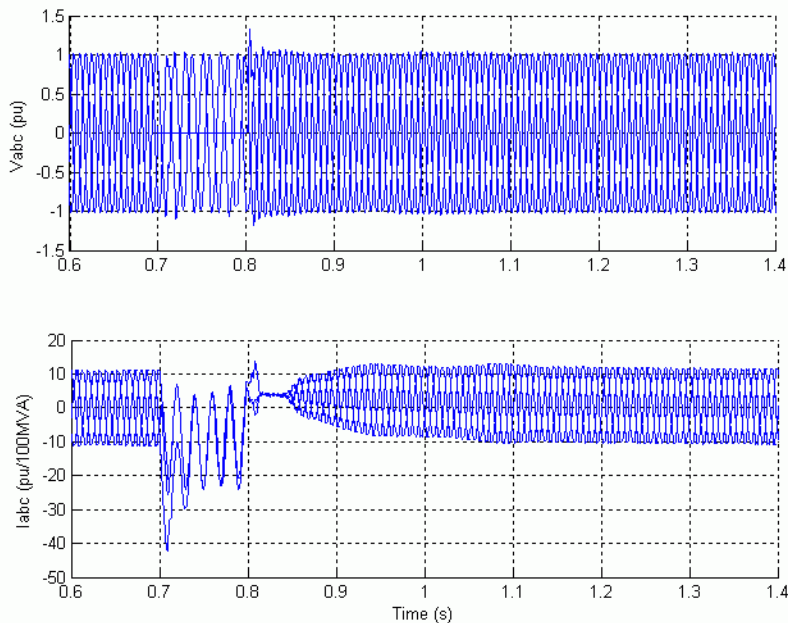

Voltages and Currents on the 50 Hz Side for an AC Line Fault on the Inverter Side

Notice the 120 Hz oscillations in the DC voltage and currents during the fault. An unavoidable commutation failure occurs at the inverter at the very beginning of the fault and the DC current increases to 2 pu. A commutation failure is the result of a failure of the incoming valve to take over the direct current before the commutation voltage reverses its polarity. The symptoms are a zero DC voltage across the affected bridge causing an increase of the DC current at a rate determined mainly by the DC circuit inductance. When the fault is cleared at $t = 0.8$ s, the VDCOL operates and reduces the reference current to 0.3 pu. The system recovers in approximately 0.35 s after fault clearing.

Look at the waveforms displayed on the PROTECTION INVERTER scope. The Low AC Voltage block detects the fault and locks the DC Fault protection that in this case should not detect a DC fault even if the DC line voltage dips. Look at the Commutation Failure Prevention Control (CFPREV) output (A_{min_I}) which decreases the maximum delay angle limit to increase the commutation margin during and after the fault.

Now open the dialog box of the CFPREV block located inside the Inverter Protections subsystem and deactivate the CFPREV protection by deselecting the “ON State.” Restart the simulation. Notice the slightly different transient behavior during and after the fault.

References

[1] Arrilaga, J., *High Voltage Direct Current Transmission*, IEEE® Power Engineering Series 6, Peter Peregrinus, Ltd., 1983.

[2] Lidong Zhang, Lars Dofnas, “A Novel Method to Mitigate Commutation Failures in HVDC Systems,” *Proceedings PowerCon 2002. International Conference on*, Volume: 1, 13–17 Oct. 2002, pp. 51–56.

VSC-Based HVDC Link

In this section...

“Introduction” on page 5-57

“Description of the HVDC Link” on page 5-57

“VSC Control System” on page 5-60

“Dynamic Performance” on page 5-66

Introduction

The increasing rating and improved performance of self-commutated semiconductor devices have made possible High Voltage DC (HVDC) transmission based on Voltage-Sourced Converter (VSC). Two technologies offered by the manufacturers are the HVDC Light [1] and the HVDC^{plus} [2].

The example described in this section illustrates modeling of a forced-commutated Voltage-Sourced Converter high-voltage direct current (VSC-HVDC) transmission link. The objectives of this example are to demonstrate the use of SimPowerSystems blocks in the simulation of a HVDC transmission link based on three-level Neutral Point Clamped (NPC) VSC converters with single-phase carrier based Sinusoidal Pulse Width Modulation (SPWM) switching. Perturbations are applied to examine the system dynamic performance.

Description of the HVDC Link

The principal characteristic of VSC-HVDC transmission is its ability to independently control the reactive and real power flow at each of the AC systems to which it is connected, at the Point of Common Coupling (PCC). In contrast to line-commutated HVDC transmission, the polarity of the DC link voltage remains the same with the DC current being reversed to change the direction of power flow.

The HVDC link described in this example is available in the `power_hvdc_vsc` model. You can run the command by entering the following in the MATLAB Command Window: `power_hvdc_vsc`. Load this model and save it in your working directory as `case5` to allow further modifications to the original system. This model shown on VSC-HVDC Transmission System Model represents a 200 MVA, +/- 100 kV VSC-HVDC transmission link.

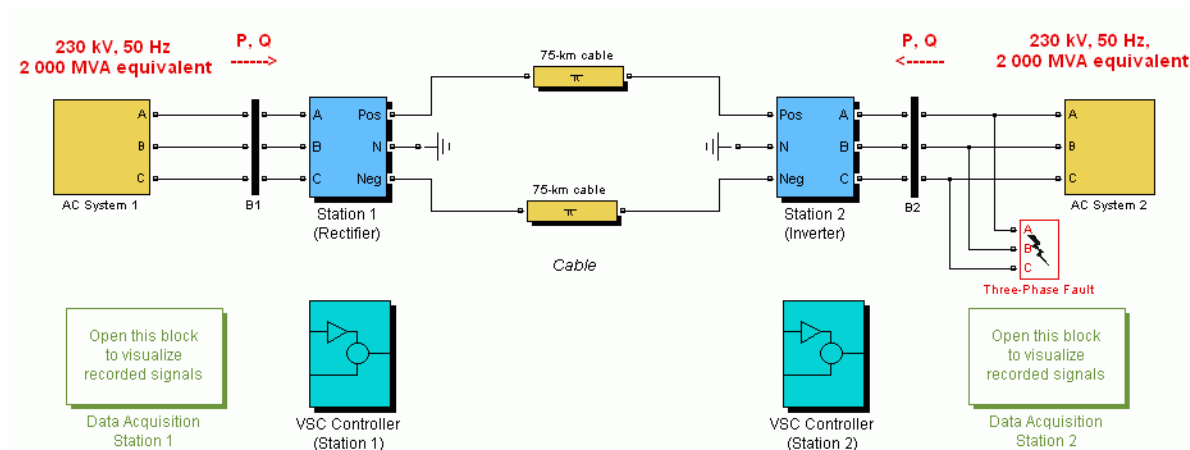

VSC-HVDC Transmission System Model

The 230 kV, 2000 MVA AC systems (AC system1 and AC system2 subsystems) are modeled by damped L-R equivalents with an angle of 80 degrees at fundamental frequency (50 Hz) and at the third harmonic. The VSC converters are three-level bridge blocks using close to ideal switching device model of IGBT/diodes. The relative ease with which the IGBT can be controlled and its suitability for high-frequency switching, has made this device the better choice over GTO and thyristors. Open the Station 1 and Station 2 subsystems to see how they are built.

A converter transformer (Wye grounded /Delta) is used to permit the optimal voltage transformation. The present winding arrangement blocks triplen harmonics produced by the converter. The transformer tap changer or saturation are not simulated. The tap position is rather at a fixed position determined by a multiplication factor applied to the primary nominal voltage of the converter transformers. The multiplication factors are chosen to have a modulation index around 0.85 (transformer ratios of 0.915 on the rectifier side and 1.015 on the inverter side). The converter reactor and the transformer leakage reactance permit the VSC output voltage to shift in phase and amplitude with respect to the AC system, and allows control of converter active and reactive power output.

To meet AC system harmonic specifications, AC filters form an essential part of the scheme. They can be connected as shunt elements on the AC system side or the converter side of the converter transformer. Since there are only high frequency harmonics, shunt filtering is therefore relatively small compared to the converter rating. It is sufficient

with a high pass-filter and no tuned filters are needed. The later arrangement is used in our model and a converter reactor, an air cored device, separates the fundamental frequency (filter bus) from the raw PWM waveform (converter bus). The AC harmonics generation [4] mainly depends on the:

- Type of modulation (e.g. single-phase or three-phase carrier based, space vector, etc.)
- Frequency index $p = \text{carrier frequency} / \text{modulator frequency}$ (e.g. $p = 1350/50 = 27$)
- Modulation index $m = \text{fundamental output voltage of the converter} / \text{pole to pole DC voltage}$

The principal harmonic voltages are generated at and around multiples of p . The shunt AC filters are 27th and 54th high pass totaling 40 Mvar. To illustrate the AC filter action, we did an FFT analysis in steady state of the converter phase A voltage and the filter bus phase A voltage, using the Powergui block. The results are shown in Phase A Voltage and FFT Analysis: (a) Converter Bus (b) Filter Bus.

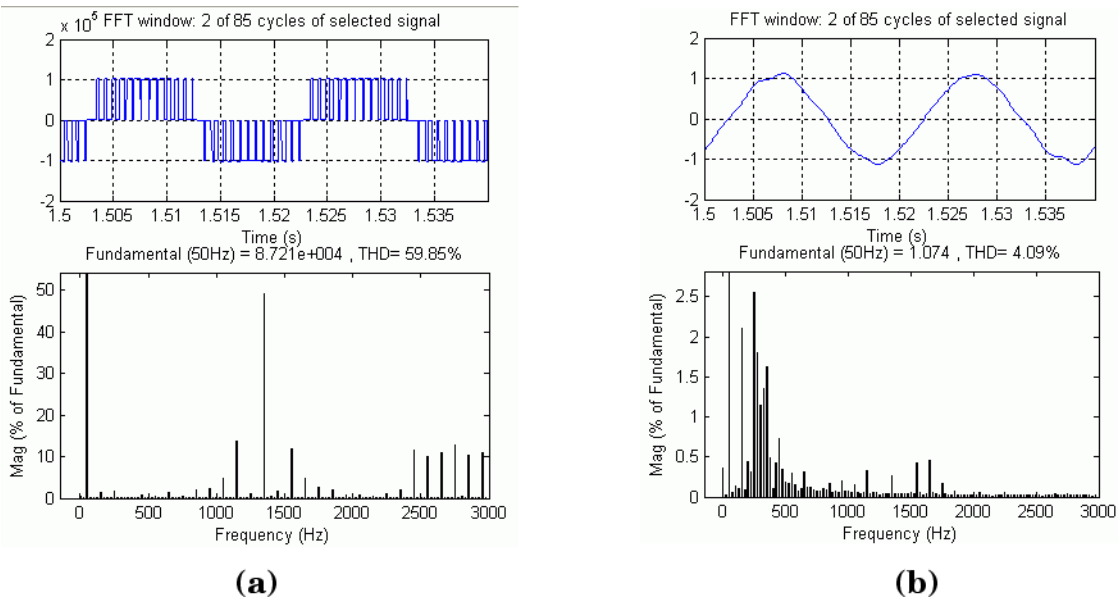

Phase A Voltage and FFT Analysis: (a) Converter Bus (b) Filter Bus

The reservoir DC capacitors are connected to the VSC terminals. They have an influence on the system dynamics and the voltage ripple on the DC side. The size of the capacitor is

defined by the time constant τ corresponding to the time it takes to charge the capacitor to the base voltage (100 kV) if it is charged with the base current (1 kA). This yields

$$\tau = C \cdot Z_{\text{base}} = 70\text{e-}6 \cdot 100 = 7 \text{ ms}$$

with $Z_{\text{base}} = 100\text{kV}/1 \text{ kA}$

The DC side filters blocking high-frequency are tuned to the 3rd harmonic, i.e., the main harmonic present in the positive and negative pole voltages. It is shown that a reactive converter current generate a relatively large third harmonic in both the positive and negative pole voltages [3] but not in the total DC voltage. The DC harmonics can also be zero-sequence harmonics (odd multiples of 3) transferred to the DC side (e.g., through the grounded AC filters). A smoothing reactor is connected in series at each pole terminal.

To keep the DC side balanced, the level of the difference between the pole voltages has to be controlled and kept to zero (see the DC Voltage Balance Control block in the VSC Controller block).

The rectifier and the inverter are interconnected through a 75 km cable (2 pi sections). The use of underground cable is typical for VSC-HVDC links. A circuit breaker is used to apply a three-phase to ground fault on the inverter AC side. A Three-Phase Programmable Voltage Source block is used in station 1 system to apply voltage sags.

VSC Control System

Overview of the Control System of a VSC Converter and Interface to the Main Circuit shows an overview diagram of the VSC control system and its interface with the main circuit [3].

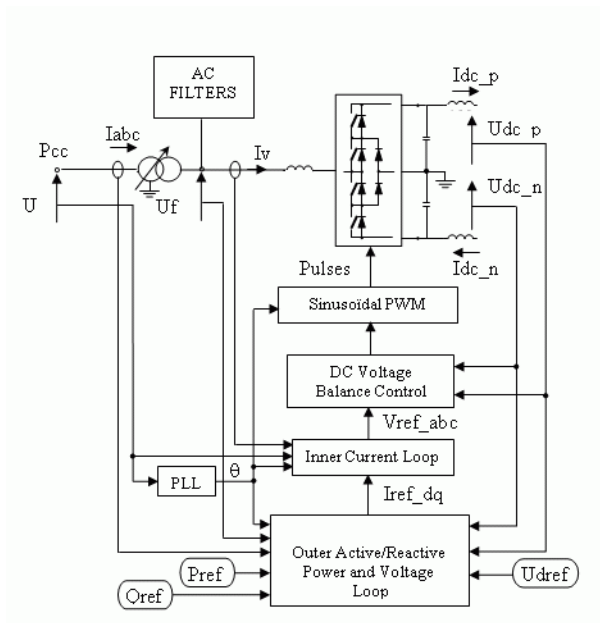

Overview of the Control System of a VSC Converter and Interface to the Main Circuit

The converter 1 and converter 2 controller designs are identical. The two controllers are independent with no communication between them. Each converter has two degrees of freedom. In our case, these are used to control:

- P and Q in station 1 (rectifier)
- Udc and Q in station 2 (inverter).

The control of the AC voltage would be also possible as an alternative to Q. This requires an extra regulator which is not implemented in our model.

A high level block diagram of the Simulink discrete VSC controller model is shown in High Level Block Diagram of the Discrete VSC Controller.

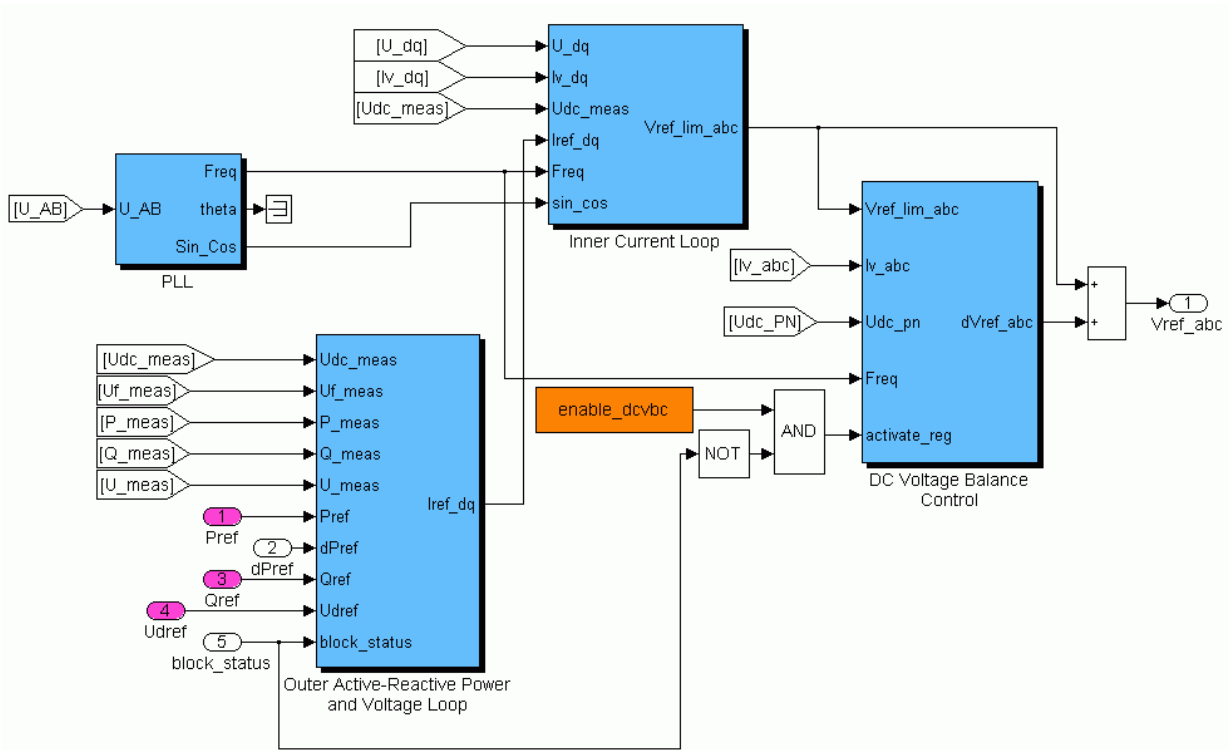

High Level Block Diagram of the Discrete VSC Controller

Open the VSC Controller subsystem to see the details.

The sample time of the controller model ($T_{s_Control}$) is $74.06 \mu s$, which is ten times the simulation sample time. The later is chosen to be one hundredth of the PWM carrier period (i.e., $0.01/1350 s$) giving an acceptable simulation precision. The power elements, the anti-aliasing filters and the PWM Generator block use the fundamental sample time (T_{s_Power}) of $7.406 \mu s$. The unsynchronized PWM mode of operation is chosen for our model.

The normalized sampled voltages and currents (in pu) are provided to the controller.

The Clark Transformations block transforms the three-phase quantities to space vector components α and β (real and imaginary part). The signal measurements (U and I) on the primary side are rotated by $\pm\pi/6$ according to the transformer connection (YD11 or YD1)

to have the same reference frame with the signal measured on the secondary side of the transformer (see block CLARK YD).

The dq transformations block computes the direct axis “d” and the quadratic axis “q” quantities (two axis rotating reference frame) from the α and β quantities.

The Signal Calculations block calculates and filters quantities used by the controller (e.g., active and reactive power, modulation index, DC current and voltage, etc.).

Phase Locked Loop (PLL)

The Phase Locked Loop block measures the system frequency and provides the phase synchronous angle Θ (more precisely $[\sin(\Theta), \cos(\Theta)]$) for the dq Transformations block. In steady state, $\sin(\Theta)$ is in phase with the fundamental (positive sequence) of the α component and phase A of the PCC voltage (U_{abc}).

Outer Active and Reactive Power and Voltage Loop

The active and reactive power and voltage loop contains the outer loop regulators that calculates the reference value of the converter current vector (I_{ref_dq}) which is the input to the inner current loop. The control modes are: in the “d” axis, either the active power flow at the PCC or the pole-to-pole DC voltage; in the “q” axis, the reactive power flow at the PCC. Note that, it would be also possible to add an AC voltage control mode at the PCC in the “q” axis. The main functions of the Active and reactive power and voltage loop are described below.

The Reactive Power Control regulator block combines a PI control with a feedforward control to increase the speed response. To avoid integrator wind-up the following actions are taken: the error is reset to zero, when the measured PCC voltage is less than a constant value (i.e., during an AC perturbation); when the regulator output is limited, the limitation error is fed back with the right sign, to the integrator input. The AC Voltage control override block, based on two PI regulators, will override the reactive power regulator to maintain the PCC AC voltage within a secure range, especially in steady-state.

The Active Power Control block is similar to the Reactive Power Control block. The extra Ramping block ramps the power order towards the desired value with an adjusted rate when the control is de-blocked. The ramped value is reset to zero when the converter is blocked. The DC Voltage control override block, based on two PI regulators, will override the active power regulator to maintain the DC voltage within a secure range, especially during a perturbation in the AC system of the station controlling the DC voltage.

The DC Voltage Control regulator block uses a PI regulator. The block is enabled when the Active Power Control block is disabled. The block output is a reference value, for the “d” component of converter current vector, for the Current Reference Limitation block.

The Current Reference Calculation block transforms the active and reactive power references, calculated by the P and Q controllers, to current references according to the measured (space vector) voltage at the filter bus. The current reference is estimated by dividing the power reference by the voltage (up to a minimum preset voltage value).

The current reference vector is limited to a maximum acceptable value (i.e., equipment dependent) by the Current Reference Limitation block. In power control mode, equal scaling is applied to the active and reactive power reference when a limit is imposed. In DC voltage control mode, higher priority is given to the active power when a limit is imposed for an efficient control of the voltage.

Inner Current Loop

The main functions of Inner Current Loop block are described below.

The AC Current Control block tracks the current reference vector (“d” and “q” components) with a feed forward scheme to achieve a fast control of the current at load changes and disturbances (e.g., so short-circuit faults do not exceed the references) [3] [5] [6]. In essence, it consist of knowing the U_dq vector voltages and computing what the converter voltages have to be, by adding the voltage drops due to the currents across the impedance between the U and the PWM-VSC voltages. The state equations representing the dynamics of the VSC currents are used (an approximation is made by neglecting the AC filters). The “d” and “q” components are decoupled to obtain two independent first-order plant models. A proportional integral (PI) feedback of the converter current is used to reduce the error to zero in steady state. The output of the AC Current Control block is the unlimited reference voltage vector Vref_dq_tmp.

The Reference Voltage Conditioning block takes into account the actual DC voltage and the theoretical maximum peak value of the fundamental bridge phase voltage in relation to the DC voltage to generate the new optimized reference voltage vector. In our model (i.e., a three-level NPC with carrier based PWM), the ratio between the maximum fundamental peak phase voltage and the DC total voltage (i.e., for a modulation index of 1) is $(\sqrt{2}) / (\sqrt{3}) = 0.816$. By choosing a nominal line voltage of 100 kV at the transformer secondary bus and a nominal total DC voltage of 200 kV the nominal modulation index would be 0.816. In theory, the converter should be able to generate up to $1/0.816$ or 1.23 pu when the modulation index is equal to 1. This voltage margin is important for

generating significant capacitive converter current (i.e., a reactive power flow to the AC system).

The Reference Voltage Limitation block limits the reference voltage vector amplitude to 1.0, since over modulation is not desired.

The Inverse dq and Inverse Clark transformation blocks are required to generate the three-phase voltage references to the PWM.

DC Voltage Balance Control

The DC Voltage Balance Control can be enabled or disabled. The difference between the DC side voltages (positive and negative) are controlled to keep the DC side of the three level bridge balanced (i.e., equal pole voltages) in steady-state. Small deviations between the pole voltages may occur at changes of active/reactive converter current or due to nonlinearity on lack of precision in the execution of the pulse width modulated bridge voltage. Furthermore, deviations between the pole voltages may be due to inherent unbalance in the circuit components impedance.

The DC midpoint current I_{d0} determines the difference U_{d0} between the upper and lower DC voltages (DC Voltages and Currents of the Three-Level Bridge) .

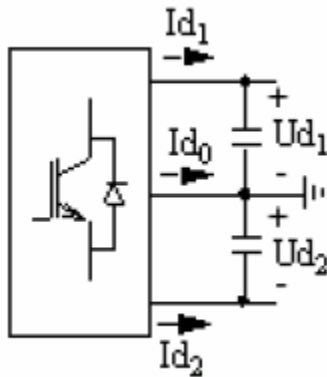

DC Voltages and Currents of the Three-Level Bridge

$$I_{d0} = -(I_{d1} + I_{d2}) = -C \cdot \frac{d}{dt}(U_{d1} - U_{d2}) = -C \cdot \frac{d}{dt}(U_{d0})$$

By changing the conduction time of the switches in a pole it is possible to change the average of the DC midpoint current I_{d_0} and thereby control the difference voltage U_{d_0} . For example, a positive difference ($U_{d_0} \geq 0$) can be decreased to zero if the amplitude of the reference voltage which generates a positive midpoint current is increased at the same time as the amplitude of the reference voltage which generates a negative DC midpoint current is decreased. This is done by the addition of an offset component to the sinusoidal reference voltage. Consequently, the bridge voltage becomes distorted, and to limit the distortion effect, the control has to be slow. Finally, for better performance this function should be activated in the station controlling the DC voltage.

Dynamic Performance

In the next sections, the dynamic performance of the transmission system is verified by simulating and observing the

- Dynamic response to step changes applied to the principal regulator references, like active/reactive power and DC voltage
- Recovery from minor and severe perturbations in the AC system

For a comprehensive explanation of the procedure followed obtaining these results and more, refer to the Model Information block.

System Startup - Steady-State and Step Response

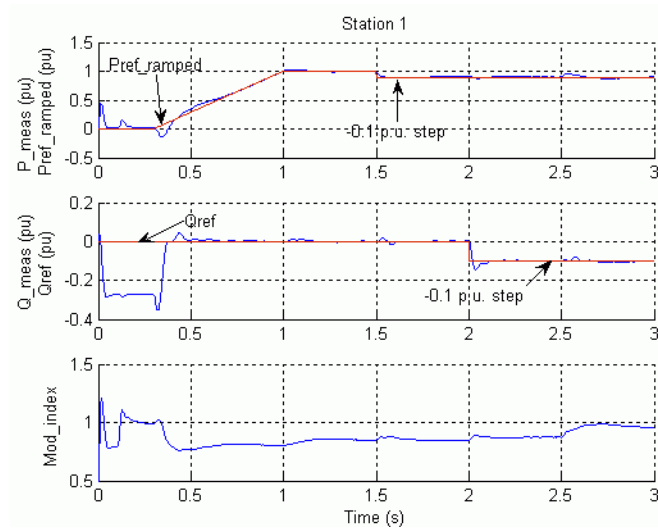

Startup and P & Q Step Responses in Station 1

The main waveforms from the scopes are reproduced below.

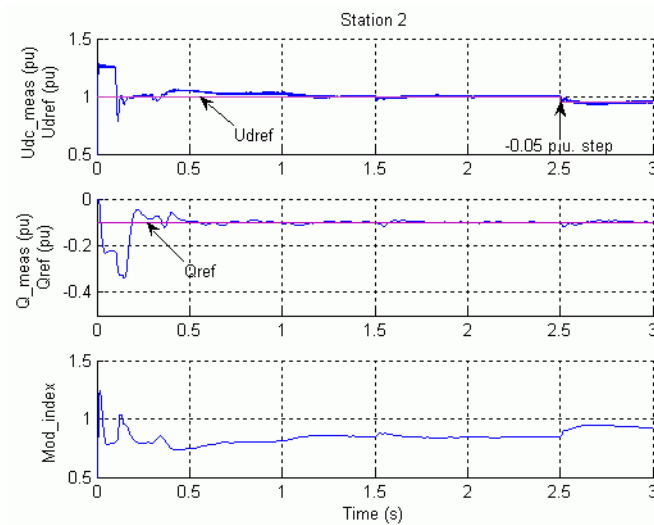

Startup and Udc Step Response in Station 2

Station 2 converter controlling DC voltage is first deblocked at $t=0.1$ s. Then, station 1 controlling active power converter is deblocked at $t=0.3$ s and power is ramped up slowly to 1 pu. Steady state is reached at approximately $t=1.3$ s with DC voltage and power at 1.0 pu (200 kV, 200 MW). Both converters control the reactive power flow to a null value in station 1 and to 20 Mvar (-0.1 pu) into station 2 system.

After steady state has been reached, a -0.1 pu step is applied to the reference active power in converter 1 ($t=1.5$ s) and later a -0.1 pu step is applied to the reference reactive power ($t=2.0$ s). In station 2, a -0.05 pu step is applied to the DC voltage reference. The dynamic response of the regulators are observed. Stabilizing time is approximately 0.3 s. The control design attempts to decouple the active and reactive power responses. Note how the regulators are more or less mutually affected.

AC Side Perturbations

From the steady-state condition, a minor and a severe perturbation are executed at station 1 and 2 systems respectively. A three-phase voltage sag is first applied at station 1 bus. Then, following the system recovery, a three-phase to ground fault is applied at station 2 bus. The system recovery from the perturbations should be prompt and stable. The main waveforms from the scopes are reproduced in the two figures below.

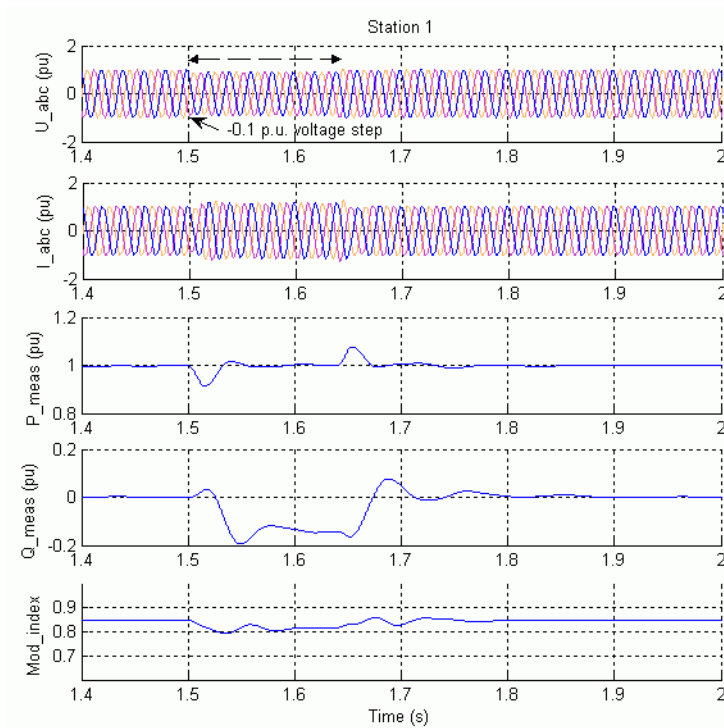

Voltage Step on AC System 1

The AC voltage step (-0.1 pu) is applied at $t=1.5$ s during 0.14 s (7 cycles) at station 1. The results show that the active and reactive power deviation from the pre-disturbance is less than 0.09 pu and 0.2 pu respectively. The recovery time is less than 0.3 s and the steady state is reached before next perturbation initiation.

The fault is applied at $t=2.1$ s during 0.12 s (6 cycles) at station 2.

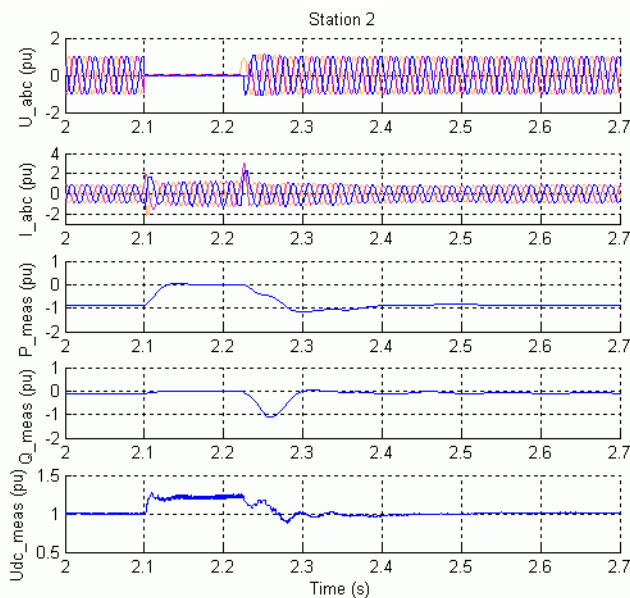

Three-Phase to Ground Fault at Station 2 Bus

Note that during the three-phase fault the transmitted DC power is almost halted and the DC voltage tends to increase (1.2 pu) since the DC side capacitance is being excessively charged. A special function (DC Voltage Control Override) in the Active Power Control (in station 1) attempts to limit the DC voltage within a fixed range. The system recovers well after the fault, within 0.5 s. Note the damped oscillations (around 10 Hz) in the reactive power.

References

- [1] Weimers, L. "A New Technology for a Better Environment," *Power Engineering Review, IEEE*, vol. 18, issue 8, Aug. 1998.
- [2] Schettler F., Huang H., and Christl N. "HVDC transmission systems using voltage source converters – design and applications," *IEEE Power Engineering Society Summer Meeting*, July 2000.
- [3] Lindberg, Anders "PWM and control of two and three level high power voltage source converters," *Licentiate thesis, ISSN-1100-1615, TRITA-EHE 9501*, The Royal Institute of Technology, Sweden, 1995.

- [4] Sadaba, Alonso, O., P. Sanchis Gurpide, J. Lopez Tanerna, I. Munoz Morales, L. Marroyo Palomo, "Voltage Harmonics Generated by 3-Level Converters Using PWM Natural Sampling," *Power Electronics Specialist Conference, 2001, IEEE 32nd Annual*, 17–21 June 2001, vol. 3, pp. 1561–1565.
- [5] Lu, Weixing, Boon-Teck Ooi, "Optimal Acquisition and Aggregation of Offshore wind Power by Multiterminal Voltage-Source HVDC," *IEEE Trans. Power Delivery*, vol. 18, pp. 201–206, Jan. 2003.
- [6] Sao, K., P.W. Lehn, M.R. Iravani, J.A. Martinez, "A benchmark system for digital time-domain simulation of a pulse-width-modulated D-STATCOM," *IEEE Trans. Power Delivery*, vol. 17, pp. 1113–1120, Oct. 2002.

Transient Stability of Power Systems Using Phasor Simulation

These case studies provide detailed, realistic examples of how to use the SimPowerSystems Specialized Technology phasor simulation method in typical power utility applications.

As explained in the section “Using the Phasor Solution Method for Stability Studies” on page 2-45, phasor simulation is the preferred method for simulating power grids when you are interested in the magnitude and phase of voltages and currents at fundamental frequency (50 Hz or 60 Hz). The phasor simulation is activated by means of the Powergui block. It supports all the elements of the SimPowerSystems Specialized Technology library. SimPowerSystems Specialized Technology also contains two libraries of phasor models of the power equipment found in utility grids (some of them including power electronics): the Flexible AC Transmission Systems (FACTS) library (`factslib`) and the Renewables library (`relib`). The case studies listed below show application examples of some of these phasor models.

- “Improve Transient Stability Using SVC and PSS” on page 6-2
- “Control Power Flow Using UPFC and PST” on page 6-8
- “Wind Farm Using Doubly-Fed Induction Generators” on page 6-18

Improve Transient Stability Using SVC and PSS

In this section...

“Introduction” on page 6-2

“Description of the Transmission System” on page 6-2

“Single-Phase Fault — Impact of PSS — No SVC” on page 6-4

“Three-Phase Fault — Impact of SVC — PSS in Service” on page 6-6

Introduction

The example described in this section illustrates modeling of a simple transmission system containing two hydraulic power plants. A static var compensator (SVC) and power system stabilizers (PSS) are used to improve transient stability and power oscillation damping of the system. The power system illustrated in this example is quite simple. However, the phasor simulation method allows you to simulate more complex power grids.

If you are not familiar with the SVC and PSS, please see the reference pages for the following blocks: Static Var Compensator (Phasor Type), Generic Power System Stabilizer, and Multiband Power System Stabilizer.

Description of the Transmission System

The single line diagram shown below represents a simple 500 kV transmission system.

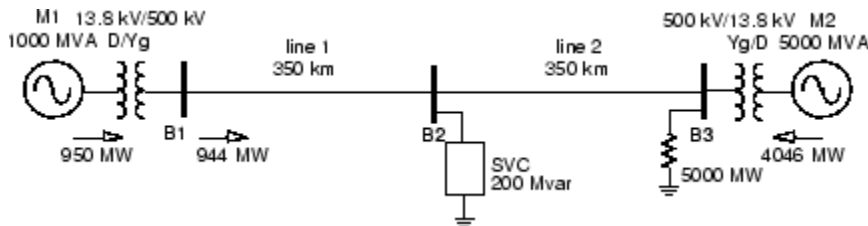

500 kV Transmission System

A 1000 MW hydraulic generation plant (M1) is connected to a load center through a long 500 kV, 700 km transmission line. The load center is modeled by a 5000 MW resistive load. The load is fed by the remote 1000 MVA plant and a local generation of 5000 MVA (plant M2).

A load flow has been performed on this system with plant M1 generating 950 MW so that plant M2 produces 4046 MW. The line carries 944 MW which is close to its surge impedance loading (SIL = 977 MW). To maintain system stability after faults, the transmission line is shunt compensated at its center by a 200 Mvar static var compensator (SVC). The SVC does not have a power oscillation damping (POD) unit. The two machines are equipped with a hydraulic turbine and governor (HTG), excitation system, and power system stabilizer (PSS).

This system is available in the `power_svc_pss` model. Load this model and save it in your working directory as `case1` to allow further modifications to the original system. This model is shown in Model of the Transmission System (`power_svc_pss`)

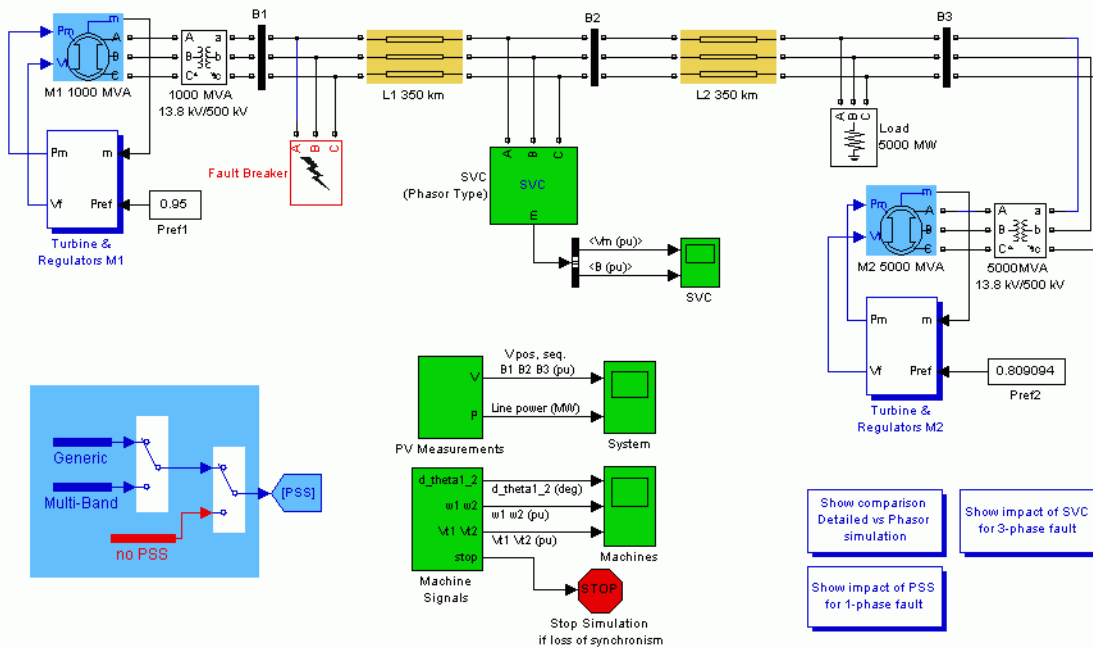

Model of the Transmission System (`power_svc_pss`)

First, look inside the two Turbine and Regulators subsystems to see how the HTG and the excitation system are implemented. Two types of stabilizers can be connected on the excitation system: a generic model using the acceleration power ($P_a =$ difference between

mechanical power P_m and output electrical power P_{eo}) and a Multiband stabilizer using the speed deviation (dw). These two stabilizers are standard models of the Fundamental Blocks/Machines library. Manual Switch blocks surrounded by a blue zone allow you to select the type of stabilizer used for both machines or put the PSS out of service.

The SVC is the phasor model from the FACTS library. Open its dialog box and check in the Power data parameters that the SVC rating is ± 200 Mvar. In the Control parameters, you can select either Voltage regulation or Var control (Fixed susceptance B_{ref}) mode. Initially the SVC is set in Var control mode with a susceptance $B_{ref}=0$, which is equivalent to having the SVC out of service.

A Fault Breaker block is connected at bus B1. You will use it to program different types of faults on the 500 kV system and observe the impact of the PSS and SVC on system stability.

To start the simulation in steady-state, the machines and the regulators have been previously initialized by means of the Machine Initialization utility of the **Powergui** block. Load flow has been performed with machine M1 defined as a PV generation bus ($V=13800$ V, $P=950$ MW) and machine M2 defined as a swing bus ($V=13800$ V, 0 degrees). After the load flow has been solved, the reference mechanical powers and reference voltages for the two machines have been automatically updated in the two constant blocks connected at the HTG and excitation system inputs: $P_{ref1}=0.95$ pu (950 MW), $V_{ref1}=1.0$ pu; $P_{ref2}=0.8091$ pu (4046 MW), $V_{ref2}=1.0$ pu.

Single-Phase Fault — Impact of PSS — No SVC

Verify that the PSSs (Generic Pa type) are in service and that a 6-cycle single-phase fault is programmed in the Fault Breaker block (Phase A checked, fault applied at $t=0.1$ s and cleared at $t=0.2$ s).

Start the simulation and observe signals on the Machines scope. For this type of fault the system is stable without SVC. After fault clearing, the 0.6 Hz oscillation is quickly damped. This oscillation mode is typical of interarea oscillations in a large power system. First trace on the Machines scope shows the rotor angle difference d_theta1_2 between the two machines. Power transfer is maximum when this angle reaches 90 degrees. This signal is a good indication of system stability. If d_theta1_2 exceeds 90 degrees for too long a period of time, the machines will lose synchronism and the system goes unstable. Second trace shows the machine speeds. Notice that machine 1 speed increases during the fault because during that period its electrical power is lower than its mechanical power. By simulating over a long period of time (50 seconds) you will also notice that the machine speeds oscillate together at a low frequency (0.025 Hz) after fault clearing.

The two PSSs (Pa type) succeed to damp the 0.6 Hz mode but they are not efficient for damping the 0.025 Hz mode. If you select instead the Multi-Band PSS, you will notice that this stabilizer type succeeds to damp both the 0.6 Hz mode and the 0.025 Hz mode.

You will now repeat the test with the two PSSs out of service. Restart simulation. Notice that the system is unstable without PSS. You can compare results with and without PSS by double-clicking on the blue block on the right side labeled “Show impact of PSS for 1-phase fault.” The displayed waveforms are reproduced below.

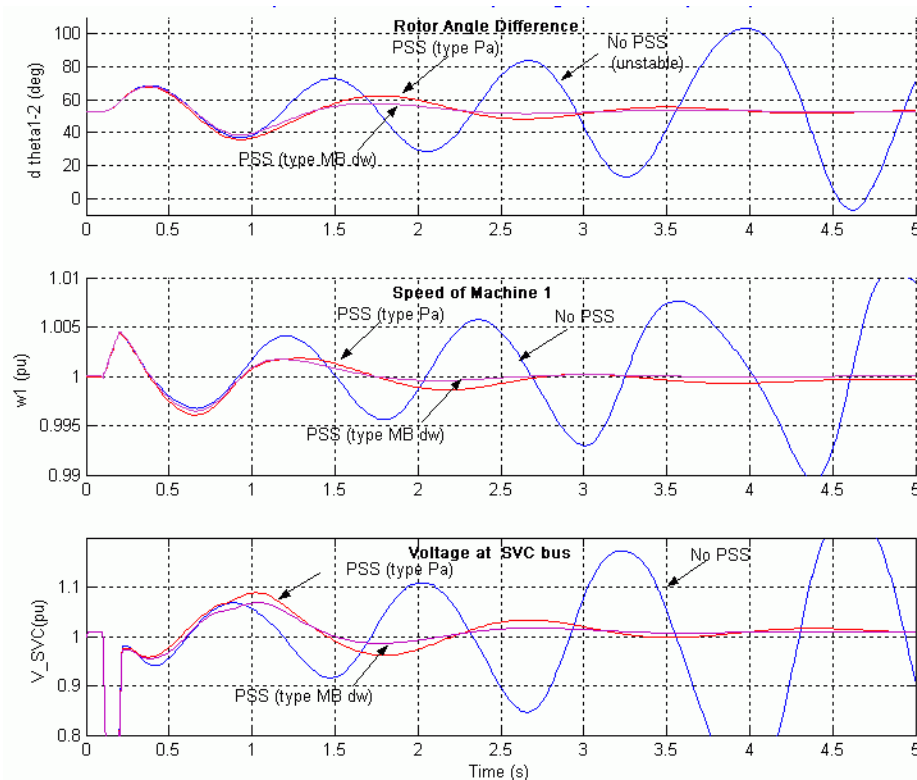

Impact of PSS for a Single-Phase Fault

Note This system is naturally unstable without PSS. If you remove the fault (by deselecting phase A in the Fault Breaker), you will see the instability slowly building up at approximately 1 Hz after a few seconds.

Three-Phase Fault — Impact of SVC — PSS in Service

You will now apply a 3-phase fault and observe the impact of the SVC for stabilizing the network during a severe contingency.

First put the two PSS (Generic Pa type) in service. Reprogram the Fault Breaker block to apply a 3-phase-to-ground fault. Verify that the SVC is in fixed susceptance mode with $B_{ref} = 0$. Start the simulation. By looking at the `d_theta1_2` signal, you should observe that the two machines quickly fall out of synchronism after fault clearing. In order not to pursue unnecessary simulation, the Simulink Stop block is used to stop the simulation when the angle difference reaches 3×360 degrees.

Now open the SVC block menu and change the SVC mode of operation to Voltage regulation. The SVC will now try to support the voltage by injecting reactive power on the line when the voltage is lower than the reference voltage (1.009 pu). The chosen SVC reference voltage corresponds to the bus voltage with the SVC out of service. In steady state the SVC will therefore be floating and waiting for voltage compensation when voltage departs from its reference set point.

Restart simulation and observe that the system is now stable with a 3-phase fault. You can compare results with and without SVC by double-clicking on the blue block labeled “Show impact of SVC for 3-phase fault.” The displayed waveforms are reproduced below.

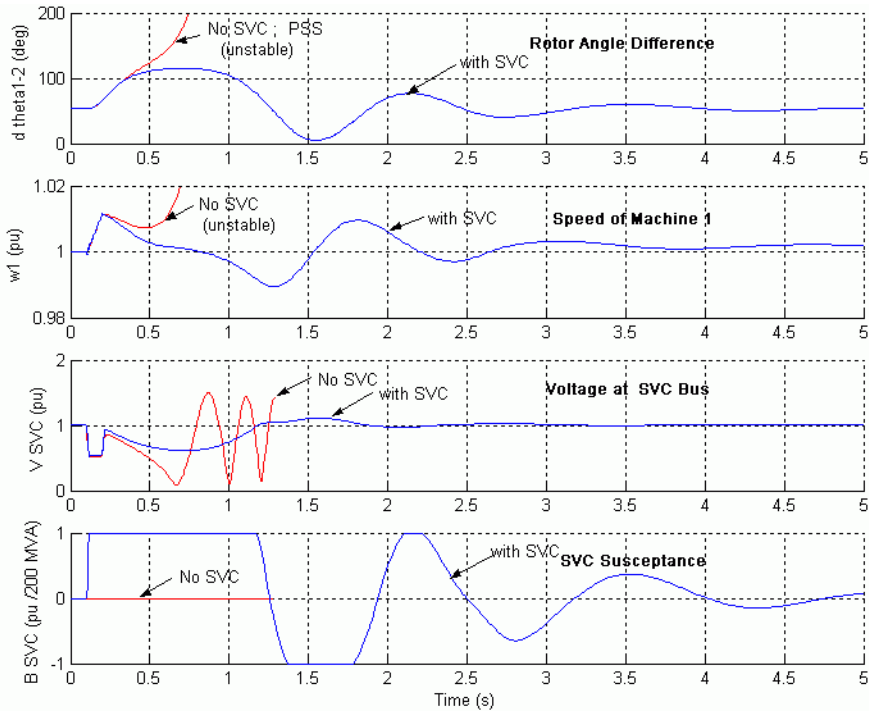

Impact of the SVC for a Three-Phase Fault

Control Power Flow Using UPFC and PST

In this section...
“Introduction” on page 6-8
“Description of the Power System” on page 6-8
“Power Flow Control with the UPFC” on page 6-11
“UPFC P-Q Controllable Region” on page 6-12
“Power Flow Control Using a PST” on page 6-13

Introduction

The example described in this section illustrates application of SimPowerSystems software to study the steady-state and dynamic performance of a unified power flow controller (UPFC) used to relieve power congestion in a transmission system.

If you are not familiar with the UPFC, please see the reference page for the Unified Power Flow Controller (Phasor Type) block.

Description of the Power System

The single-line diagram of the modeled power system is shown in 500 kV / 230 kV Transmission System.

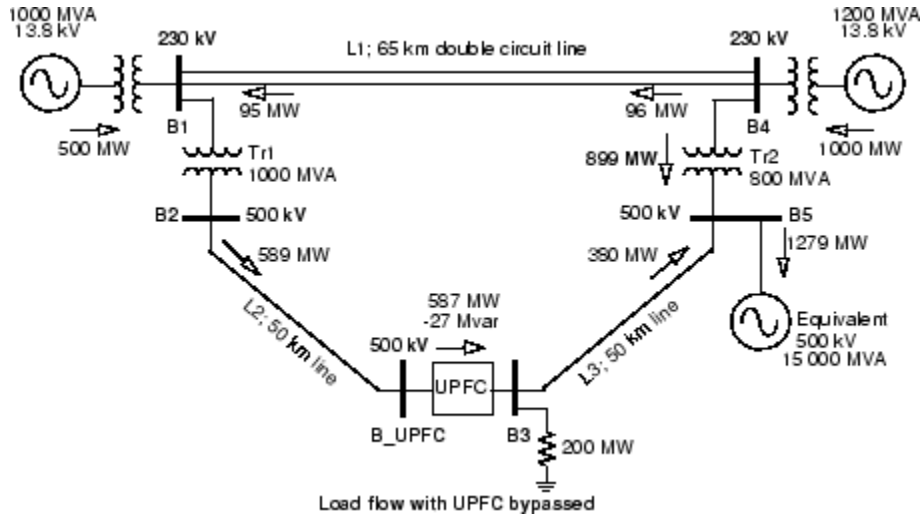

500 kV / 230 kV Transmission System

A UPFC is used to control the power flow in a 500 kV / 230 kV transmission system. The system, connected in a loop configuration, consists essentially of five buses (B1 to B5) interconnected through three transmission lines (L1, L2, L3) and two 500 kV/230 kV transformer banks Tr1 and Tr2. Two power plants located on the 230 kV system generate a total of 1500 MW which is transmitted to a 500 kV, 15000 MVA equivalent and to a 200 MW load connected at bus B3. Each plant model includes a speed regulator, an excitation system as well as a power system stabilizer (PSS). In normal operation, most of the 1200 MW generation capacity of power plant #2 is exported to the 500 kV equivalent through two 400 MVA transformers connected between buses B4 and B5. For this example we are considering a contingency case where only two transformers out of three are available ($\text{Tr2} = 2 \times 400 \text{ MVA} = 800 \text{ MVA}$). The load flow shows that most of the power generated by plant #2 is transmitted through the 800 MVA transformer bank (899 MW out of 1000 MW) and that 96 MW is circulating in the loop. Transformer Tr2 is therefore overloaded by 99 MVA. The example illustrates how a UPFC can relieve this power congestion. The UPFC located at the right end of line L2 is used to control the active and reactive powers at the 500 kV bus B3, as well as the voltage at bus B_UPFC. The UPFC consists of two 100 MVA, IGBT-based, converters (one shunt converter and one series converter interconnected through a DC bus). The series converter can inject a maximum of 10% of nominal line-to-ground voltage (28.87 kV) in series with line L2.

This example is available in the `power_upfc` model. Load this model and save it in your working directory as `case2` to allow further modifications to the original system. This model is shown in Model of the UPFC Controlling Power on a 500 kV/230 kV Power System (`power_upfc`).

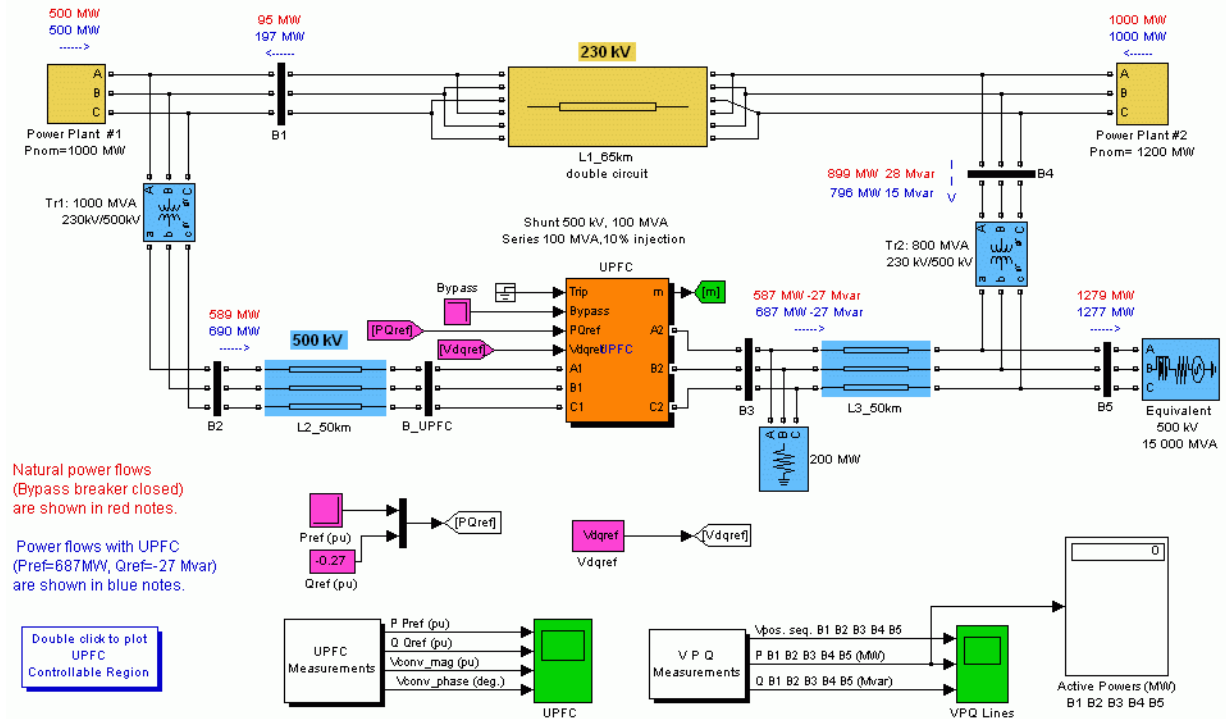

Model of the UPFC Controlling Power on a 500 kV/230 kV Power System (`power_upfc`)

Using the Machine Initialization tool of the Powergui block, the model has been initialized with plants #1 and #2 generating respectively 500 MW and 1000 MW and with the UPFC out of service (Bypass breaker closed). The resulting power flow obtained at buses B1 to B5 is indicated on the model by red numbers. This load flow corresponds to load flow shown in the single-line diagram, in 500 kV / 230 kV Transmission System.

Power Flow Control with the UPFC

Parameters of the UPFC are given in the dialog box. Verify, in the Power data parameters, that the series converter is rated 100 MVA with a maximum voltage injection of 0.1 pu. The shunt converter is also rated 100 MVA. Also verify, in the control parameters, that the shunt converter is in Voltage regulation mode and that the series converter is in Power flow control mode. The UPFC reference active and reactive powers are set in the magenta blocks labeled P_{ref}(pu) and Q_{ref}(pu). Initially the Bypass breaker is closed and the resulting natural power flow at bus B3 is 587 MW and -27 Mvar. The P_{ref} block is programmed with an initial active power of 5.87 pu corresponding to the natural power flow. Then, at t=10s, P_{ref} is increased by 1 pu (100 MW), from 5.87 pu to 6.87 pu, while Q_{ref} is kept constant at -0.27 pu.

Run the simulation and look on the UPFC scope how P and Q measured at bus B3 follow the reference values. Waveforms are reproduced below.

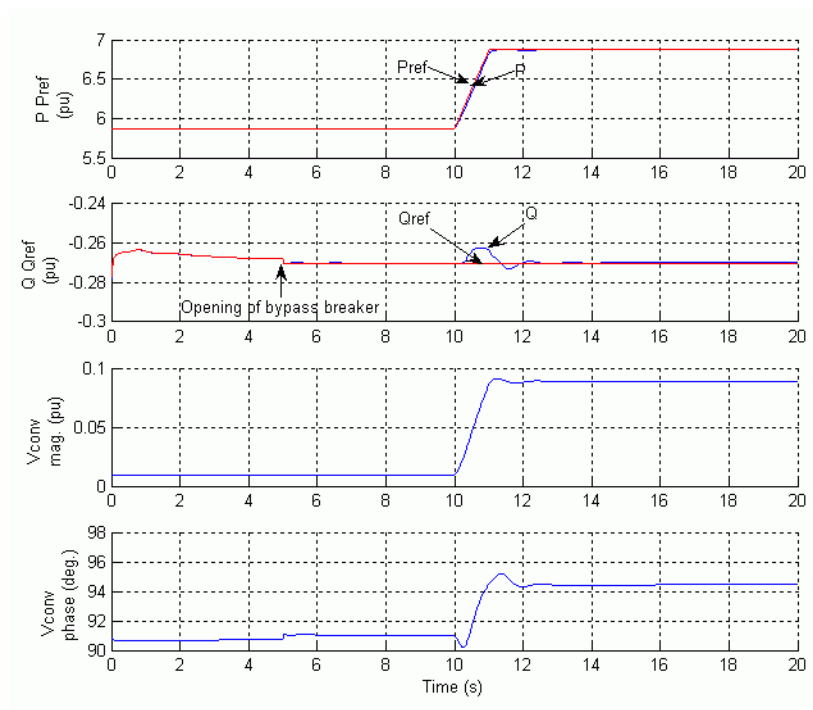

UPFC Dynamic Response to a Change in Reference Power from 587 MW to 687 MW

At $t=5$ s, when the Bypass breaker is opened, the natural power is diverted from the Bypass breaker to the UPFC series branch without noticeable transient. At $t=10$ s, the power increases at a rate of 1 pu/s. It takes one second for the power to increase to 687 MW. This 100 MW increase of active power at bus B3 is achieved by injecting a series voltage of 0.089 pu with an angle of 94 degrees. This results in an approximate 100 MW decrease in the active power flowing through Tr2 (from 899 MW to 796 MW), which now carries an acceptable load. See the variations of active powers at buses B1 to B5 on the VPQ Lines scope.

UPFC P-Q Controllable Region

Now, open the UPFC dialog box and select Show Control parameters (series converter). Select Mode of operation = Manual Voltage injection. In this control mode the voltage generated by the series inverter is controlled by two external signals V_d , V_q multiplexed at the V_{dqref} input and generated in the V_{dqref} magenta block. For the first five seconds the Bypass breaker stays closed, so that the PQ trajectory stays at the (-27Mvar, 587 MW) point. Then when the breaker opens, the magnitude of the injected series voltage is ramped, from 0.0094 to 0.1 pu. At 10 s, the angle of the injected voltage starts varying at a rate of 45 deg/s.

Run the simulation and look on the UPFC scope the P and Q signals who vary according to the changing phase of the injected voltage. At the end of the simulation, double-click on the blue block labeled "Double click to plot UPFC Controllable Region." The trajectory of the UPFC reactive power as function of its active power, measured at bus B3, is reproduced below. The area located inside the ellipse represents the UPFC controllable region.

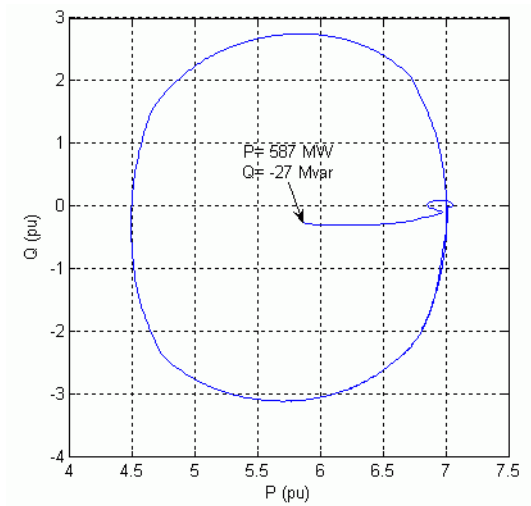

UPFC Controllable Region

Power Flow Control Using a PST

Although not as flexible as the UPFC, the phase shifting transformer (PST) is nevertheless a very efficient means to control power flow because it acts directly on the phase angle δ , as shown in Power Transfer Between Two Voltage Sources Without and With PST. The PST is the most commonly used device to control power flow on power grids.

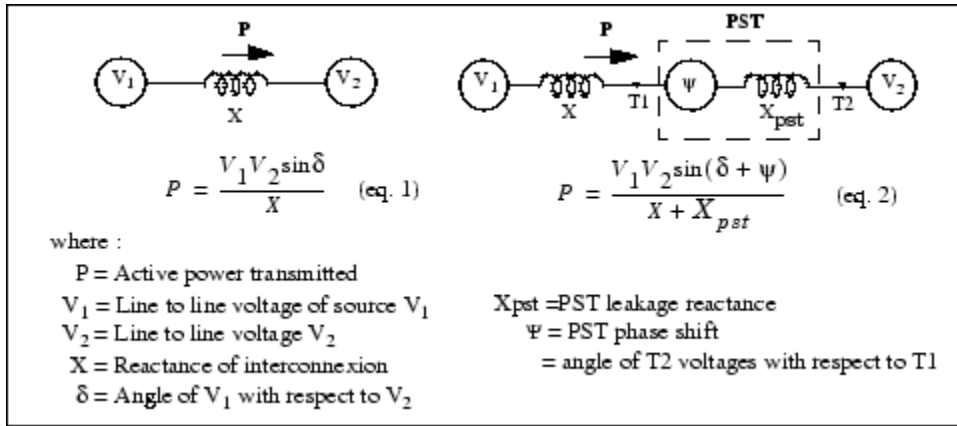

Power Transfer Between Two Voltage Sources Without and With PST

You will now use a PST with an on load tap changer (OLTC) to control the power flow on your power system. A phasor model of PST using the delta hexagonal connection is available in the FACTS/Transformers library. For details on this PST connection, please refer to the Three-Phase OLTC Phase Shifting Transformer Delta-Hexagonal (Phasor Type) block reference page.

Delete the UPFC block in your model as well as the magenta blocks controlling the UPFC. Also delete the UPFC Measurements subsystem and the UPFC scope. Open the Transformer subsystem of the FACTS library and copy the Three-Phase OLTC Phase Shifting Transformer Delta-Hexagonal (Phasor Type) block in your model. Connect the ABC terminals to the B_UPFC bus and connect the abc terminals to the B3 bus. Now, open the PST block dialog box and modify the following parameters:

Nominal parameters [Vnom(Vrms Ph Ph) Pnom(VA) Fnom (Hz)]	[500e3 800e6 60]
Number of taps per half tapped winding	20

The nominal power is set to 800 MVA (maximum expected power transfer through the PST). The number of taps is set to 20, so that the phase shift resolution is approximately $60/20 = 3$ degrees per step.

In the power system, the natural power flow (without PST) from B_UPFC to B3 is $P = +587$ MW. If V_1 and V_2 in Power Transfer Between Two Voltage Sources Without and

With PST represent the internal voltages of systems connected respectively to B_UPFC and B3, it means that the angle δ of equation 1 is positive. Therefore, according to equation 2, to increase power flow from B_UPFC to B3, the PST phase shift Ψ of abc terminals with respect to ABC terminals must be also positive. For this type of PST the taps must be moved in the negative direction. This is achieved by sending pulses to the Down input of the PST tap changer.

The tap position is controlled by sending pulses to either the Up input or the Down input. In our case, as we need to increase phase shift from zero toward positive values, we have to send pulses to the Down input. Copy a Pulse Generator block from the Simulink Sources library and connect it to the Down input of the PST. Open the block dialog box and modify the following parameters:

Period	5
Pulse Width (% of period)	10

Therefore, every 5 seconds the taps will be moved by one step in the negative direction and the phase shift will increase by approximately 3 degrees.

Finally, connect a Bus Selector block (from the Simulink Signal Routing library) to the measurement output m of the PST. Open its dialog box and select the following two signals:

- Tap
- Psi (degrees)

Connect these two signals to a two input scope to observe the tap position and the phase shift during simulation. Set the simulation time to 25 s and start simulation.

On the VPQ lines scope, observe voltages at buses B1 to B5 and active and reactive power transfer through these buses. The variation of tap position, PST phase shift Ψ and active power transfer through bus B3 (power through PST) and B4 (power through transformer Tr2) are reproduced on the figure below.

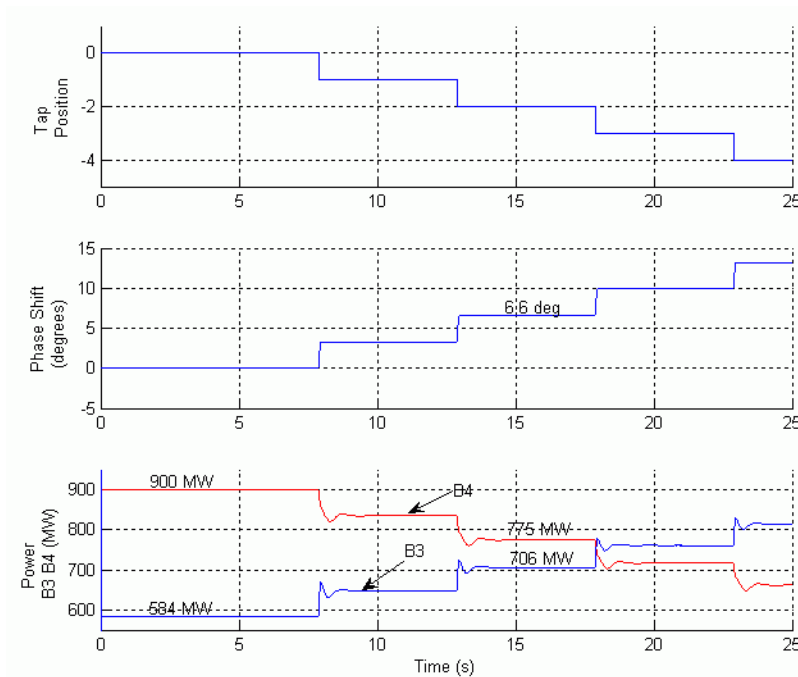

Control of Active Power Through B3 and B4 by Changing Tap Position of PST

Each tap change produces a phase angle variation of approximately 3 degrees, resulting in a 60 MW power increase through B3. At tap position -2, the power through transformer Tr2 as decreased from 900 MW to 775 MW, thus achieving the same goal as the UPFC for steady state control. You could get a better resolution in phase angle and power steps by increasing the number of taps in the OLTC.

You can notice that the discrete variation of phase angle produces overshoots and slight oscillations in active power. These power oscillations which are typical interarea electromechanical oscillations of machines in power plants 1 and 2 are quickly damped by the power system stabilizers (PSSs) connected on the excitation systems.

If you disconnect the PSS from the vstab input of the excitation system (located in the Reg_M1 and Reg_M2 subsystems of the power plants) you will realize the impact of PSS on interarea oscillation damping. The active power through B3 with and without PSS is reproduced below. Without PSS, the 1.2 Hz under damped power oscillations are clearly unacceptable.

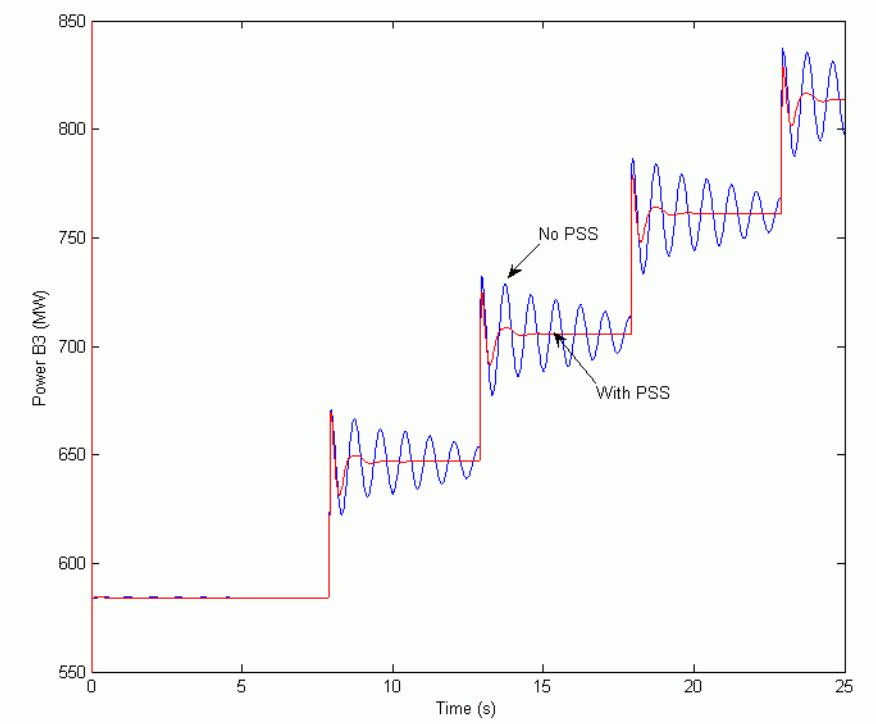

Damping of Power Oscillations by PSS

Wind Farm Using Doubly-Fed Induction Generators

In this section...

“Description of the Wind Farm” on page 6-18

“Turbine Response to a Change in Wind Speed” on page 6-22

“Simulation of a Voltage Sag on the 120 kV System” on page 6-24

“Simulation of a Fault on the 25 kV System” on page 6-26

Description of the Wind Farm

The example described in this section illustrates application of SimPowerSystems software to study the steady-state and dynamic performance of a 9 MW wind farm connected to a distribution system.

The wind farm consists of six 1.5 MW wind turbines connected to a 25 kV distribution system exporting power to a 120 kV grid through a 30 km 25 kV feeder. A 2300V, 2 MVA plant consisting of a motor load (1.68 MW induction motor at 0.93 PF) and of a 200 kW resistive load is connected on the same feeder at bus B25. A 500 kW load is also connected on the 575 V bus of the wind farm. The single-line diagram of this system is illustrated in Single-Line Diagram of the Wind Farm Connected to a Distribution System.

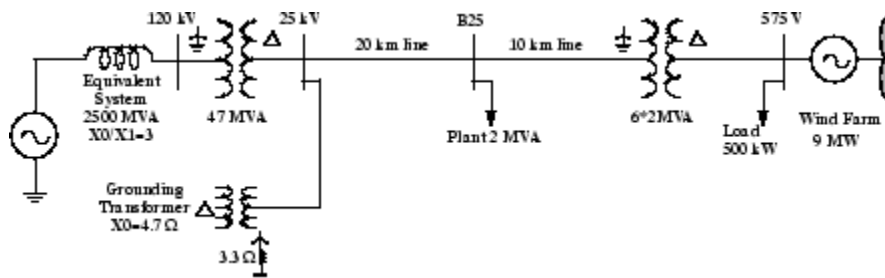

Single-Line Diagram of the Wind Farm Connected to a Distribution System

Both the wind turbine and the motor load have a protection system monitoring voltage, current and machine speed. The DC link voltage of the DFIG is also monitored. Wind

turbines use a doubly-fed induction generator (DFIG) consisting of a wound rotor induction generator and an AC/DC/AC IGBT-based PWM converter. The stator winding is connected directly to the 60 Hz grid while the rotor is fed at variable frequency through the AC/DC/AC converter. The DFIG technology allows extracting maximum energy from the wind for low wind speeds by optimizing the turbine speed, while minimizing mechanical stresses on the turbine during gusts of wind. The optimum turbine speed producing maximum mechanical energy for a given wind speed is proportional to the wind speed (see Wind Turbine Doubly-Fed Induction Generator (Phasor Type) block of the relib/Wind Generation library for more details). Another advantage of the DFIG technology is the ability for power electronic converters to generate or absorb reactive power, thus eliminating the need for installing capacitor banks as in the case of squirrel-cage induction generators.

This system is available in the `power_wind_dfig` model. Load this model and save it in your working directory as `case3` to allow further modifications to the original system. The SimPowerSystems diagram is shown in Single-Line Diagram of the Wind Farm Connected to a Distribution System and SimPowerSystems Diagram of the 2 MVA Plant with Its Protection System. In this case study, the rotor is running at subsynchronous speed for wind speeds lower than 10 m/s and it is running at a super-synchronous speed for higher wind speeds. The turbine mechanical power as function of turbine speed is displayed in for wind speeds ranging from 5 m/s to 16.2 m/s. These characteristics are obtained with the specified parameters of the Turbine data (Turbine Data Menu and the Turbine Power Characteristics).

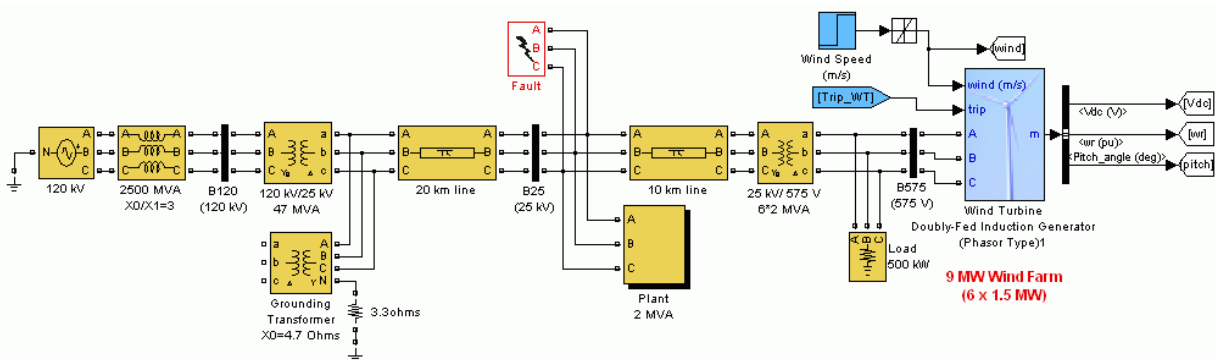

SimPowerSystems Diagram of the Wind Farm Connected to the Distribution System (`power_wind_dfig`)

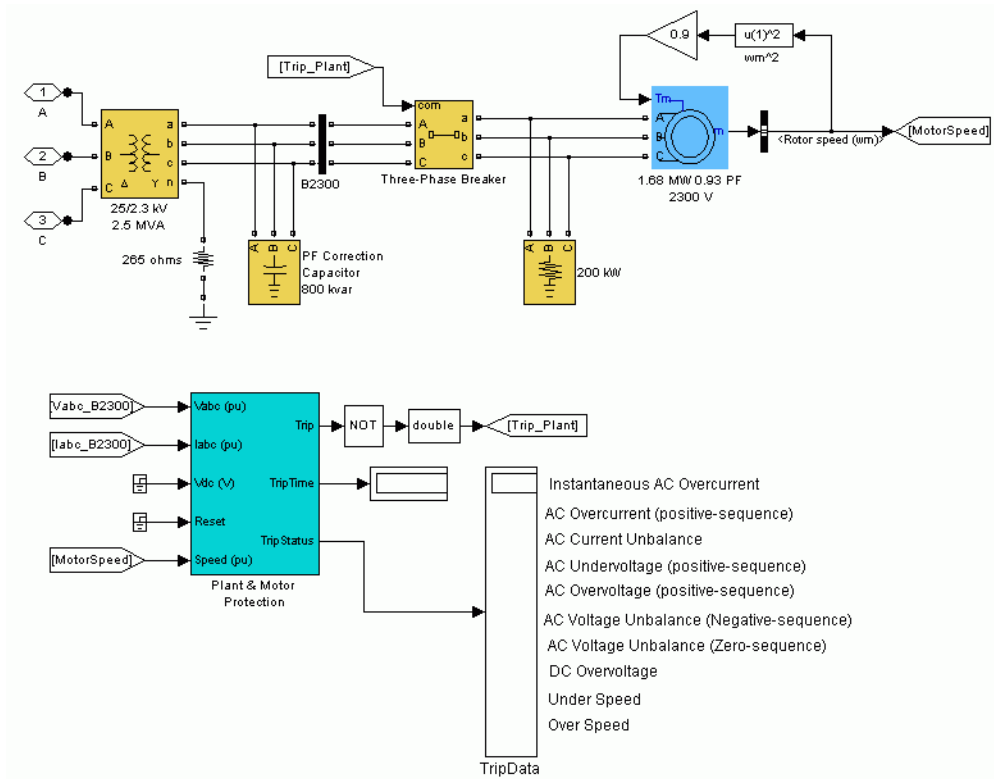

SimPowerSystems Diagram of the 2 MVA Plant with Its Protection System

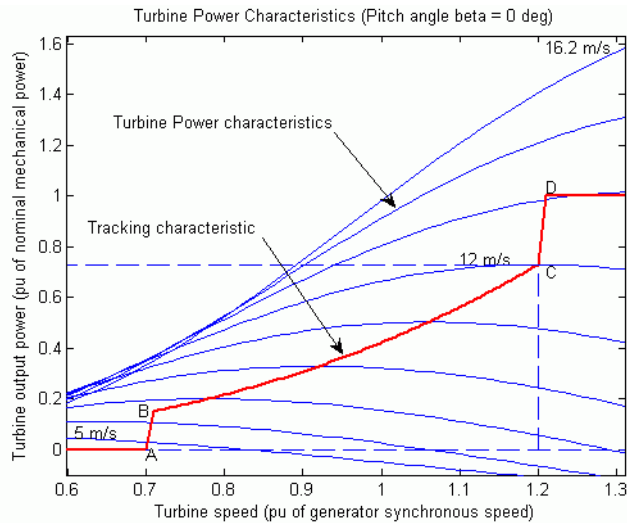
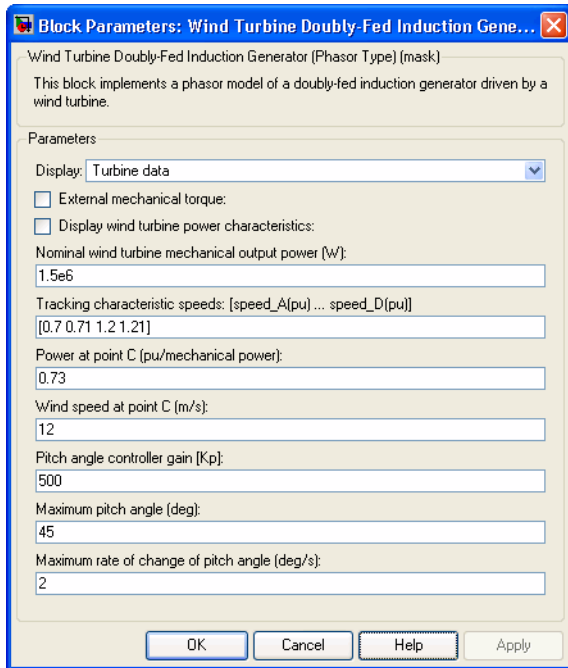

Turbine Data Menu and the Turbine Power Characteristics

The DFIG is controlled to follow the ABCD curve in Turbine Data Menu and the Turbine Power Characteristics. Turbine speed optimization is obtained between point B and point C on this curve.

The wind turbine model is a phasor model that allows transient stability type studies with long simulation times. In this case study, the system is observed during 50 s. The 6-wind-turbine farm is simulated by a single wind-turbine block by multiplying the following three parameters by six, as follows:

- The nominal wind turbine mechanical output power: $6 \times 1.5 \text{e}6$ watts, specified in the **Turbine data** menu
- The generator rated power: $6 \times 1.5/0.9$ MVA (6×1.5 MW at 0.9 PF), specified in the **Generator data** menu
- The nominal DC bus capacitor: 6×10000 microfarads, specified in the **Converters data** menu

The mode of operation is set to **Voltage regulation** in the **Control Parameters** dialog box. The terminal voltage will be controlled to a value imposed by the reference voltage ($V_{\text{ref}}=1$ pu) and the voltage droop ($X_s=0.02$ pu).

Turbine Response to a Change in Wind Speed

Observe the turbine response to a change in wind speed. Initially, wind speed is set at 8 m/s, and then at $t=5$ s, wind speed increases suddenly at 14 m/s. Waveforms for a Gust of Wind (Wind Farm in Voltage Regulation Mode) illustrates the waveforms associated with this simulation. At $t=5$ s, the generated active power starts increasing smoothly (together with the turbine speed) to reach its rated value of 9MW in approximately 15s. Over that time frame the turbine speed increases from 0.8 pu to 1.21 pu. Initially, the pitch angle of the turbine blades is zero degree and the turbine operating point follows the red curve of the turbine power characteristics up to point D. Then the pitch angle is increased from 0 deg to 0.76 deg to limit the mechanical power. Observe also the voltage and the generated reactive power. The reactive power is controlled to maintain a 1 pu voltage. At nominal power, the wind turbine absorbs 0.68 Mvar (generated $Q=-0.68$ Mvar) to control voltage at 1pu. If you change the mode of operation to **Var regulation** with the **Generated reactive power Qref** set to zero, you will observe that the voltage increases to 1.021 pu when the wind turbine generates its nominal power at unity power factor (Waveforms for a Gust of Wind (Wind Farm in Var Regulation Mode)).

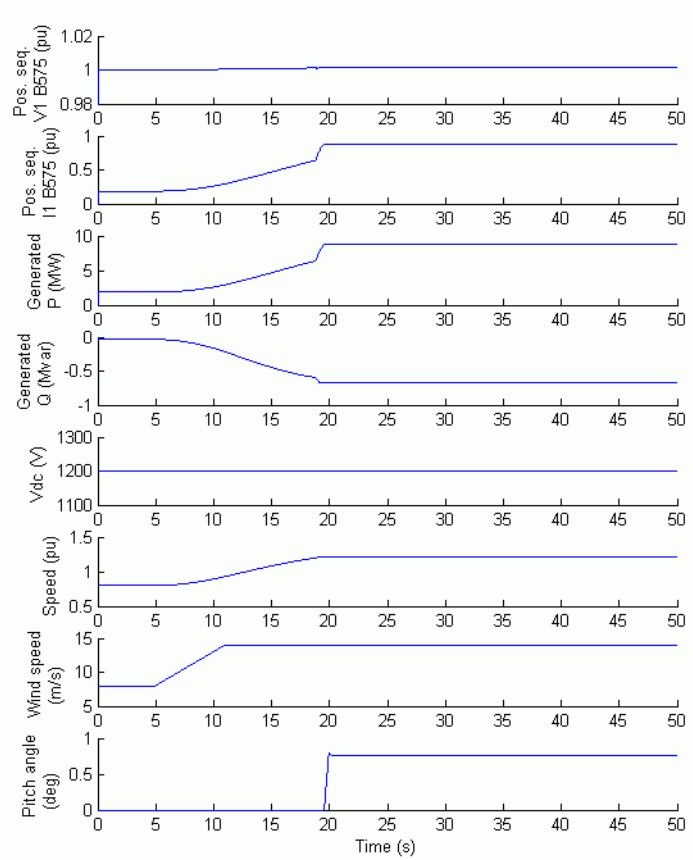

Waveforms for a Gust of Wind (Wind Farm in Voltage Regulation Mode)

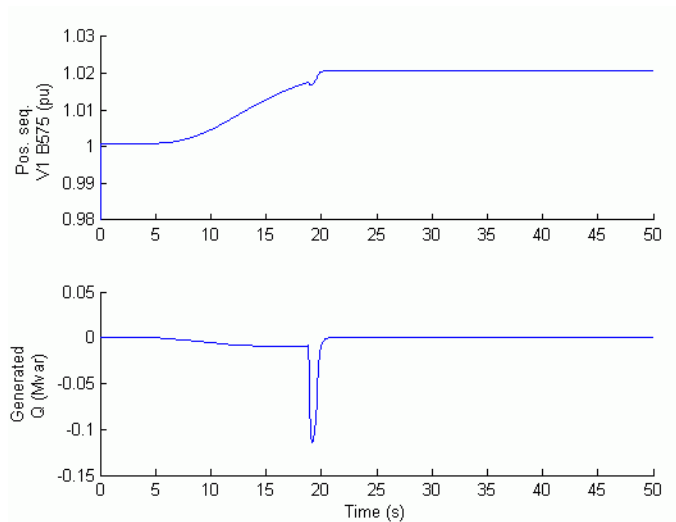

Waveforms for a Gust of Wind (Wind Farm in Var Regulation Mode)

Simulation of a Voltage Sag on the 120 kV System

Now observe the impact of a voltage sag resulting from a remote fault on the 120 kV system. In this simulation the mode of operation is initially *Var regulation* with $Q_{ref}=0$ and the wind speed is constant at 8 m/s. A 0.15 pu voltage drop lasting 0.5 s is programmed, in the 120 kV voltage source menu, to occur at $t=5$ s. The simulation results are illustrated in *Voltage Sag on the 120 kV System (Wind Farm in Var Regulation Mode)*. Observe the plant voltage and current as well as the motor speed. Note that the wind farm produces 1.87 MW. At $t=5$ s, the voltage falls below 0.9 pu and at $t=5.22$ s, the protection system trips the plant because an undervoltage lasting more than 0.2 s has been detected (exceeding protection settings for the Plant subsystem). The plant current falls to zero and motor speed decreases gradually, while the wind farm continues generating at a power level of 1.87 MW. After the plant has tripped, 1.25 MW of power (P_{B25} measured at bus B25) is exported to the grid.

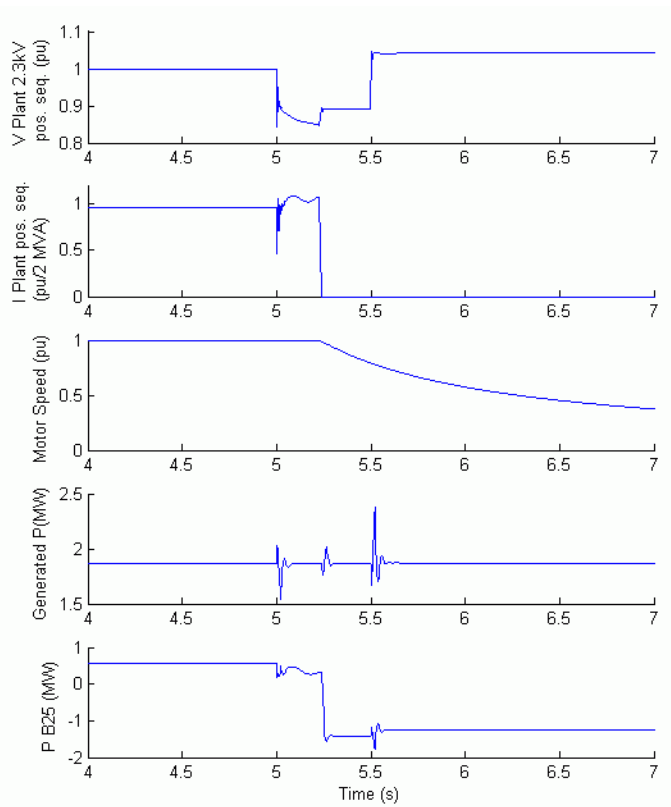

Voltage Sag on the 120 kV System (Wind Farm in Var Regulation Mode)

Now, the wind turbine control mode is changed to Voltage regulation and the simulation is repeated. You will notice that the plant does not trip anymore. This is because the voltage support provided by the 5 Mvar reactive power generated by the wind turbines during the voltage sag keeps the plant voltage above the 0.9 pu protection threshold. The plant voltage during the voltage sag is now 0.93 pu (Voltage Sag on the 120 kV System (Wind Farm in Voltage Regulation Mode)).

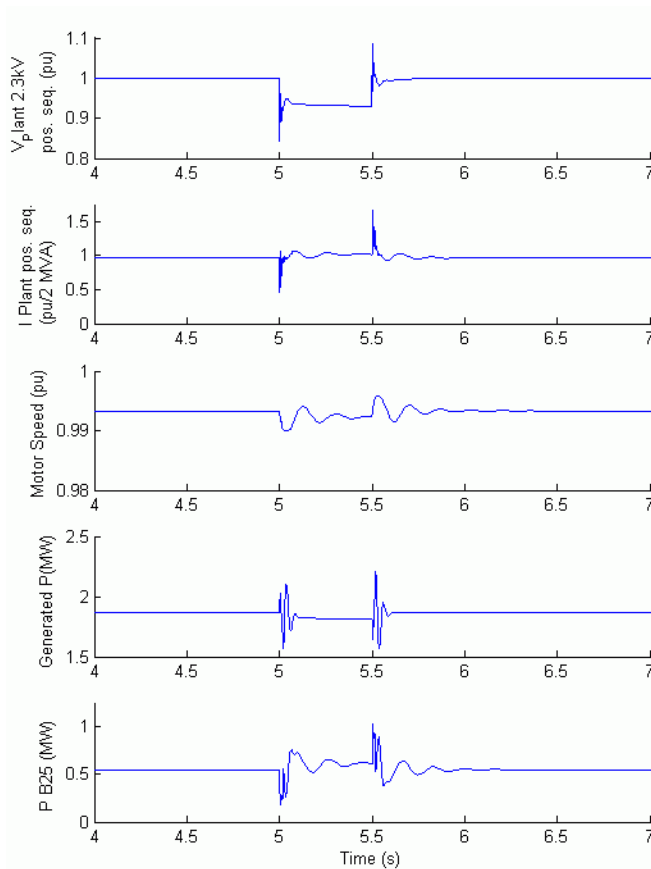

Voltage Sag on the 120 kV System (Wind Farm in Voltage Regulation Mode)

Simulation of a Fault on the 25 kV System

Finally, now observe the impact of a single phase-to-ground fault occurring on the 25 kV line. At $t=5$ s a 9 cycle (0.15 s) phase-to-ground fault is applied on phase A at B25 bus. When the wind turbine is in **Voltage regulation mode**, the positive sequence voltage at wind turbine terminals ($V1_B575$) drops to 0.8 pu during the fault, which is above the undervoltage protection threshold (0.75 pu for a $t>0.1$ s). The wind farm therefore stays in service (Wind Farm Waveforms During Fault at Bus B25 (Wind Farm in Voltage Regulation Mode)). However, if the **Var regulation mode** is used with $Q_{ref}=0$, the

voltage drops under 0.7 pu and the undervoltage protection trips the wind farm. We can now observe that the turbine speed increases. At $t=40$ s the pitch angle starts to increase to limit the speed (Wind Farm Waveforms During Fault at Bus B25 (Wind Farm in Var Regulation Mode)).

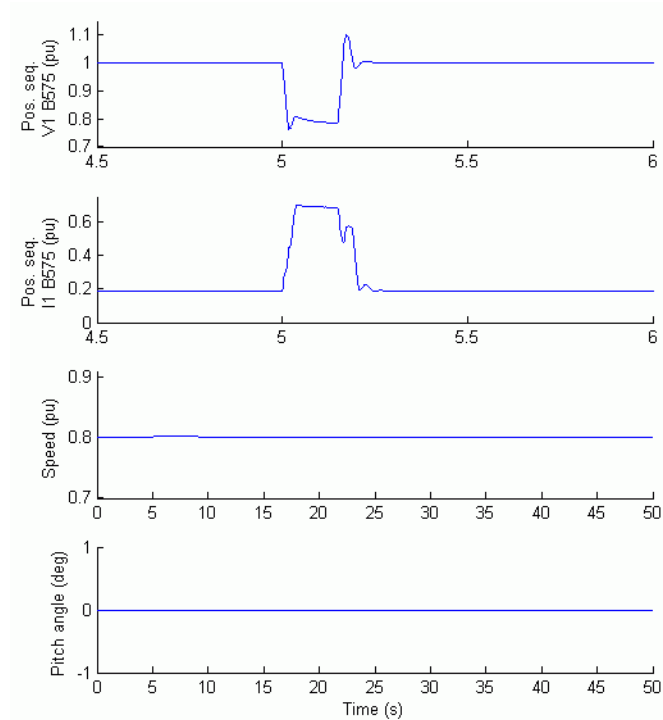

Wind Farm Waveforms During Fault at Bus B25 (Wind Farm in Voltage Regulation Mode)

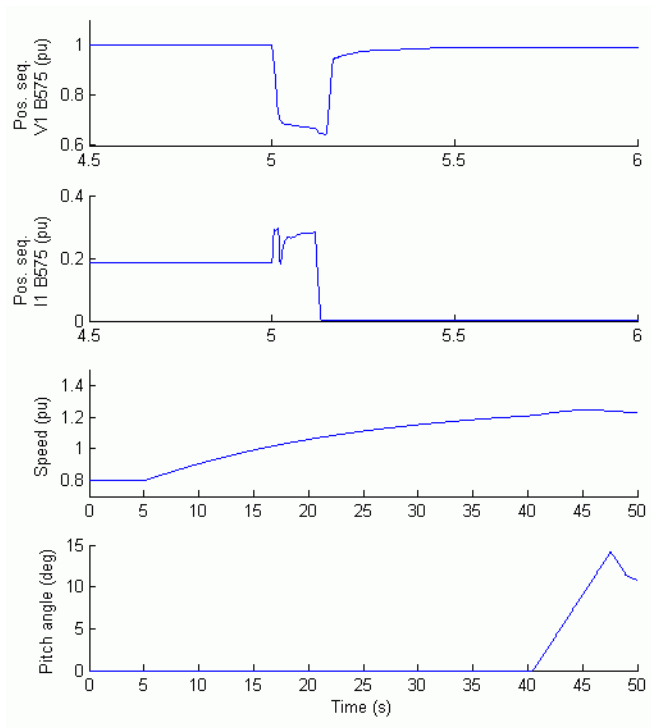

Wind Farm Waveforms During Fault at Bus B25 (Wind Farm in Var Regulation Mode)